

# HOBBY AREA MANAGEMENT DISTRICT



## HOBBY AREA DISTRICT

Agenda and Agenda Materials  
Meeting of the Board of Directors

---

October 8, 2020



## HOBBY AREA DISTRICT

**TO: THE BOARD OF DIRECTORS OF THE HOBBY AREA DISTRICT AND TO ALL OTHER INTERESTED PERSONS:**

**NOTICE** is hereby given that a regular meeting of the Board of Directors of the Hobby Area District will be held on Thursday, October 8, 2020, at 1:00 p.m., via Zoom videoconference at: <https://us02web.zoom.us/j/87193329705?pwd=Vk5hL2dsRndEOEhIRVN3UXhyYytUQT09> - or via teleconference at: **1-346-248-7799** US (Houston), Meeting ID: **871 9332 9705**, Passcode: **070743**, open to the public, to consider, discuss, and make recommendations, and take direct actions as may be necessary, desirable, or convenient with respect to the following matters:

### AGENDA

1. Call to order; determine quorum.
2. Public comments.
3. Approve Minutes of Board Meeting held August 13, 2020.
4. Receive Bookkeeper's Report and approve payment of invoices.
5. Receive Assessments Collection and Delinquency Report.
6. Discuss Clark Condon's updated cost estimate relating to the underpass project
7. Approve Agreement for Supplemental Professional Services by and between Hobby Area Management District and Hawes Hill & Associates, LLP.
8. Authorize Executive Director to set date, time, and place for hearing on Supplemental Assessment Roll and Appoint Hearing Examiner.
9. Authorize Executive Director to prepare and solicit requests for qualifications and proposals for bookkeeping and accounting services.
10. Authorize Executive Director to enter into a contract with a new payroll provider.
11. Authorize Executive Director to enter into a contract with Smartscape for quarterly mowing/clean-up along the BNSF rail line.
12. Discuss and authorize FY2021 Budget.
13. Set and approve Board and Committee meeting dates for remainder of 2020 and FY2021.
14. Executive Director's Report/Board Member or Staff Announcements.
15. Next Meeting – November 12, 2020.
16. Adjourn

*Beth Strope*

---

Executive Director



\*As a result of the current COVID-19 virus epidemic emergency, the convening at one location of a quorum of the Board is difficult or impossible. Therefore, the Board will conduct this meeting by teleconference call rather than by physical quorum pursuant to Texas Government Code Sec. 551.125 and guidance of the Governor of the State of Texas. Members of the public are entitled to participate and address the Board during the telephonic meeting. In all respects, this meeting will be open to the public and compliant with applicable law and guidance of the Governor of the State of Texas. An electronic copy of the agenda packet (which consists of the regular reports presented to the Board by its consultants) can be found at <https://hadistrict.org/>



# HOBBY AREA DISTRICT

(HARRIS COUNTY IMPROVEMENT DISTRICT NO. 9)  
CITY OF HOUSTON  
HARRIS COUNTY, TEXAS

---

---

## AGENDA MEMORANDUM

---

---

To: Hobby Area District Board of Directors  
From: Executive Director  
Subject: Agenda Item Materials

---

3. Approve Minutes of Board Meeting held August 13, 2020.

**MINUTES OF THE MEETING OF THE  
HOBBY AREA DISTRICT  
BOARD OF DIRECTORS**

**August 13, 2020**

**DETERMINE QUORUM; CALL TO ORDER.**

The Board of Directors of the Hobby Area Management District held a regular meeting on Thursday, August 13, 2020, at 1:00 p.m. via Zoom videoconference and via teleconference, with access available to the public pursuant to Texas Government Code Section 551.125 and Governor Greg Abbott's emergency disaster declaration dated March 13, 2020, and the roll was called of the members of the Board being present by electronic means, to-wit:

Position 1, Danny Perkins, Chair

Position 2, Helen Bonsall, Vice Chair

Position 3, Liliana Rambo

Position 4, Ann Collum

Position 5, vacant

Position 6, Keyur Amin

Position 7, Joe Edd Nelson

Position 8, Darryl Bailey

Position 9, James Brown, Secretary/Treasurer

and all the above were present, except Director Bailey, thus constituting a quorum.

Also present were Beth Strobe, Executive Director; Susan Hill, David Hawes, Josh Hawes, Alan Bernstein, Tony Allender, Brian Burks, Buddy Tautenhahn, Alice Lee, Danny Benavides, and Leticia Rodriguez all of Hawes Hill & Associates, LLP; Jack Roland, Governmental Financial Reporting, LLC; Debbie Bessire, Equi-Tax, Inc.; Tim Austin, Allen Boone Humphries Robinson LLP; Brian Toldan, McCall Gibson Swedlund Barfoot PLLC; Erica Rocha, S.E.A.L. Security; and Sheila Condon, Brendan Cloney and Craig Minor, Clark Condon & Associates. Chairman Perkins called the meeting to order at 1:04 p.m.

**PUBLIC COMMENTS.**

There were no public comments.

**APPROVE MINUTES OF BOARD MEETING, JUNE 11, 2020.**

Upon a motion duly made by Director Brown, and being seconded by Director Bonsall, the Board voted unanimously to approve the Minutes of the June 11, 2020, Board meeting, as presented.

**REVIEW AND ACCEPT BOOKKEEPER'S REPORT.**

Mr. Roland presented the Bookkeeper's Report and went over invoices, included in the Board materials. Upon a motion duly made by Director Bonsall, and being seconded by Director Nelson,



the Board voted unanimously to accept the Bookkeeper's financial report and approved payment of invoices, as presented.

#### **REVIEW AND ACCEPT ASSESSMENT COLLECTION AND DELINQUENT REPORT.**

Ms. Bessire presented the Assessment Collection and Delinquency Report, included in the Board materials. She reported a 98% collection rate on the 2019 assessments: a total revenue of \$14,431.41 for the month and \$3,447,321 in uncertified value for 2019. Upon a motion duly made by Director Brown, and being seconded by Director Rambo, the Board voted unanimously to accept the Assessment Collection and Delinquency Report as presented.

#### **APPROVE FY2019 ANNUAL FINANCIAL REPORT AND AUDIT FROM McCALL GIBSON SWEDLUND BARFOOT, PLLC.**

Director Brown presented the FY2019 Annual Financial Report and Audit, included in the Board materials. He recorded the Finance Committee has reviewed the Audit and is recommending for approval. Upon a motion duly made by Director Collum and being seconded by Director Amin, the Board voted unanimously to approve the FY2019 Annual Financial Report and Audit, as presented.

#### **RECEIVE PRESENTATION FROM CLARK CONDON, LLC, REGARDING HOBBY AREA PRELIMINARY GATEWAY DESIGNS.**

Ms. Condon provided an overview on the Hobby Area Preliminary Gateway Designs. She provided a presentation of existing conditions and correctives at four problem area intersections on I-45 South: Airport Blvd; Monroe Blvd; Bellfort St.; and Broadway St. Mr. Minor went over locations and District branding on entry monuments and ID markers at the four intersections. He provided an overview of the monument concepts and using kinetic panels, metal column accents, painted column accents, underpass barrier concepts and the differences between each. Ms. Condon reported there will be a maintenance contract with TxDOT and the District. Mr. Hawes reported the Broadway St. intersection can be updated even though it is not located in the District. No action from the Board was required.

#### **CONSIDER PROPOSAL FROM THE TRIBE DESIGN FOR GRAPHIC DESIGN SERVICES FOR DISTRICT NEWSLETTER; AND AUTHORIZE EXECUTIVE OF AGREEMENT.**

Ms. Strobe reported three proposals were received for graphic design services for the District Newsletter. She reported after review by the Committee, the Committee is recommending awarding the services to Tribe Design. She provided an overview of Tribe Design's qualifications and went over the cost analysis. She stated the District can use Tribe Design not only for the District's Newsletter but for future projects within the District. Upon a motion duly made by

Director Bonsall, and being seconded by Director Rambo, the Board voted unanimously to award the contract for graphic design services for the District's Newsletter to Tribe Design; and authorized execution of Agreement with Tribe Design.

**CONSIDER PROPOSAL FROM UPART STUDIO FOR REFRESHING PAINTED SURFACES OF DISTRICT'S MINI-MURAL'S; AND AUTHORIZ EXECUTION OF AGREEMENT.**

Ms. Strope provided an overview assessment of the District's Mini Murals created by UpArt Studio. She reported the need to add a mini mural on a utility box that was previously decommissioned and to refresh 14 existing utility boxes. Upon a motion duly made by Director Bonsall, and being seconded by Director Brown, the Board voted unanimously to approve the proposal from UpArt Studio to refresh the existing 14 utility boxes in the amount of \$2,500.00.

**2:21 p.m. Director Bailey arrives meeting**

**APPROVE LETTER AGREEMENTS NECESSARY TO SET UP OFF-DUTY POLICE OFFICER SERVICES.**

Ms. Strope reported additional off-duty police officer services for the District are needed for an additional 120 hours to assist in the implementation of District plans and strategies; monitor crime patterns; and conduct proactive patrols within the District. Mr. Burks reported the officers would provide daily interactions with the community at the Districts' direct control. Ms. Strope reported the additional cost would allow for two police vehicles with District logos to patrol at one time throughout the District. Mr. Burks reported the service can always be tailored to the District's needs. Chairman Perkins stated the service includes the presence of the officer, the ability to arrest, the detainment of the offender(s) but also employ DRT problem solving strategies to assist with issues including homeless encampments, panhandling, trespassing, robbery and burglary. Ms. Strope suggested starting with 120 to 140 hours as a starting point. Director Collum inquired on how long it would take to select a supervisor? Ms. Strope reported she is currently reviewing several applications. Upon a motion duly made by Director Bonsall, and being seconded by Director Bailey, the Board voted unanimously to approve the Letter Agreement for security services to set up off-duty police officer services, as presented.

**APPROVE RECOGNITION OF LT. IRVING.**

Ms. Strope recognized Lt. Irving for his services in the District. No action from the Board was required.

## **APPOINT BUDGET COMMITTEE AND NOMINATING COMMITTEE.**

Chairman Perkins reported on the appointment of the Budget Committee and Nomination Committee. He reported the Committees will consist of the following individuals: Director James Brown as Chairman of the Committee, Director Bonsall and Director Nelson.

## **DISCUSS STRATEGIES FOR MONITORING ACTIVITIES WITH POTENTIAL IMPACT ON THE DISTRICT DURING THE LEGISLATIVE SESSION WHICH CONVENES IN JANUARY 2021.**

Item was tabled.

**EXECUTIVE SESSION – Convene Executive Session pursuant to Section 551.074, Texas Government Code, to deliberate the appointment, employment, evaluation, reassignment, duties, discipline, or dismissal of a public officer or employee.**

**RECONVENE IN OPEN SESSION – Reconvene in Open Session and authorize appropriate action regarding the appointment, employment, evaluation, reassignment, duties, discipline, or dismissal of a public officer or employee.**

An Executive Session was not called.

## **EXECUTIVE DIRECTOR’S REPORT / BOARD MEMBER STAFF OR STAFF ANNOUNCEMENTS.**

Ms. Strobe presented the Executive Director’s Report. She reported the Executive Committee approved (1) \$500.00 for the purchase of 200 calculators for this year’s HPD HISD Back to School Supply Drive and (2) partnership with Memorial Herman Hospital for community outreach materials in the amount of \$2,500.00. She reported the community outreach with Commissioner Garcia’s office includes distribution of masks and Census materials in English, Spanish and Vietnamese. She reported she is currently working with Baker Ripley House on its scheduled food distribution event. She reported on clean-up efforts with Senator Carol Alvarado’s office of the BNSDF railway on Mykawa Drive. She reported Senator Alvarado’s requested the District provide mowing and litter abatement services quarterly on the right-of-way of BNSF’s property. She reported discussions with SEAL Security to provide 24/7 coverage in the District, at no additional cost. She reported SEAL Security is assigning Officer Nobles to the District to assist with relationship building with panhandlers and homeless encampments. She reported HPD Officer Castillo and SEAL Security Officer Nobles are working with CVS to file No Trespassing Affidavits for the recent homeless encampment. She reported coordination with District apartment owners and managers for training from United Against Human Trafficking. She reported an interlocal agreement with the County Attorney’s Office to assist with ongoing prostitution and human trafficking complaints. She reported two Broadway Esplanade banner signs were damaged and are being repaired. She reported Mr. Benavides is currently working on the

District's Business Directory. She reported due to COVID-19 the District's Holiday Social Event has been cancelled this year.

Mr. Benavides presented the District's Field Service Operator Report, included in the Board materials. He reported he will be moving his days to Monday and Thursday, due to inactivity on Tuesdays.

**2:29 p.m. Director Rambo left meeting: a quorum was still present.**

Ms. Rocha presented the July 2020 SEAL Security Incident Report, included in the Board materials. She reported she would include a categorized notation going forward.

Director Bonsall reported overflowing trash cans at the bus depot shelters. Mr. Tautenhahn stated he will speak with Ms. Chavez and get the matter resolved.

**NEXT MEETING - DECEMBER 10, 2020.**

The Board affirmed the date of its next meeting.

**ADJOURN.**

There being no further business to come before the Board, Chair Perkins adjourned the meeting at 3:13 p.m.

---

Secretary





# HOBBY AREA DISTRICT

(HARRIS COUNTY IMPROVEMENT DISTRICT NO. 9)  
CITY OF HOUSTON  
HARRIS COUNTY, TEXAS

---

---

## AGENDA MEMORANDUM

---

---

To: Hobby Area District Board of Directors  
From: Executive Director  
Subject: Agenda Item Materials

---

4. Receive Bookkeeper's Report and approve payment of invoices.

# **HOBBY AREA DISTRICT**

MONTHLY FINANCIAL REPORT

**AUGUST 31, 2020**

*G*overnmental  
*F*inancial  
*R*eporting, LLC

**Hobby Area District  
Balance Sheet  
As of August 31, 2020**

Aug 31, 20

ASSETS

Current Assets

Checking/Savings

1010 · Amegy Bank	50,936.58
1020 · Wells Fargo Bank	197,497.38
1030 · Plains State Bank - CD	255,293.93
1032 · Plus4 Credit Union - CD	5.34
1040 · TexSTAR-Operating	<u>1,724,919.46</u>

Total Checking/Savings 2,228,652.69

Other Current Assets

1200 · Assessment Receivable	<u>55,530.87</u>
------------------------------	------------------

Total Other Current Assets 55,530.87

Total Current Assets 2,284,183.56

Other Assets

1230 · Due From Improvement Corp	<u>5,582.16</u>
----------------------------------	-----------------

Total Other Assets 5,582.16

TOTAL ASSETS 2,289,765.72

LIABILITIES & EQUITY

Liabilities

Current Liabilities

Accounts Payable

2000 · Accounts Payable	<u>110,486.33</u>
-------------------------	-------------------

Total Accounts Payable 110,486.33

Other Current Liabilities

2100 · Assessment Refunds Payable	18,070.93
-----------------------------------	-----------

2200 · Deferred Assessment Revenue	<u>680,975.07</u>
------------------------------------	-------------------

Total Other Current Liabilities 699,046.00

Total Current Liabilities 809,532.33

Total Liabilities 809,532.33

Equity

3000 · Retained Earnings	1,188,466.94
--------------------------	--------------

Net Income	<u>291,766.45</u>
------------	-------------------

Total Equity 1,480,233.39

TOTAL LIABILITIES & EQUITY 2,289,765.72

**Hobby Area District**  
**Statement of Sources & Uses - Budget vs Actual**  
**August 2020**

	Aug 20	Budget	Jan - Aug 20	YTD Budget	Annual Budget
<b>MAINTENANCE &amp; OPERATIONS FUND</b>					
<b>M&amp;O SOURCES OF FUNDS</b>					
4000 · District Assessments	166,797.05	158,333.00	1,360,067.10	1,266,664.00	1,900,000.00
4010 · Penalty & Interest Revenue	2,291.40	3,000.00	19,065.49	24,000.00	36,000.00
4020 · Overpayments	25,896.06	5,583.00	59,783.61	44,664.00	67,000.00
4030 · Assessment Refunds	-17,712.83	-5,667.00	-53,932.86	-45,336.00	-68,000.00
4060 · Interest Revenue	273.23	1,667.00	9,690.40	13,336.00	20,000.00
<b>TOTAL M&amp;O SOURCES OF FUNDS</b>	<b>177,544.91</b>	<b>162,916.00</b>	<b>1,394,673.74</b>	<b>1,303,328.00</b>	<b>1,955,000.00</b>
<b>M&amp;O USES OF FUNDS</b>					
<b>Public Safety</b>					
6010 · Contract Public Safety	28,907.50	25,208.00	178,381.52	201,664.00	302,500.00
6012 · Specific Sites High Density Patrol	0.00	5,417.00	0.00	43,336.00	65,000.00
6014 · Special Operations	0.00	10,000.00	0.00	80,000.00	120,000.00
6015 · Apartment Life Initiatives	1,657.25	1,667.00	13,258.00	13,336.00	20,000.00
6020 · Mobile Cameras	1,700.00	2,547.00	5,100.00	20,376.00	30,560.00
6025 · Nuisance Abatement Program	971.76	1,250.00	8,135.68	10,000.00	15,000.00
6035 · Graffiti Abatement	3,400.00	3,125.00	23,800.00	25,000.00	37,500.00
6037 · Public Safety Programs	0.00	333.00	0.00	2,664.00	4,000.00
<b>Total Public Safety</b>	<b>36,636.51</b>	<b>49,547.00</b>	<b>228,675.20</b>	<b>396,376.00</b>	<b>594,560.00</b>
<b>Community Development</b>					
6050 · Porter Service	14,302.28	13,750.00	113,678.47	110,000.00	165,000.00
6051 · Community Enhancement Programs	337.25	6,750.00	3,648.60	54,000.00	81,000.00
6052 · Corridor & ROW Maintenance	20,587.45	34,583.00	195,009.20	276,664.00	415,000.00
6053 · Field Services Vehicle	26.00	933.00	72.04	7,464.00	11,200.00
6054 · Street Sweeping	7,617.20	7,167.00	60,937.60	57,336.00	86,000.00
8055 · Project/Contract Management	9,000.00	10,417.00	51,250.00	83,336.00	125,000.00
8063 · Esplanade/Roadway Enhancement	915.00	4,167.00	9,518.98	33,336.00	50,000.00
8065 · METRO Bus Shelter Enhancement	0.00	1,833.00	0.00	14,664.00	22,000.00
8074 · Streetscape Assessories	0.00	583.00	0.00	4,664.00	7,000.00
<b>Total Community Development</b>	<b>52,785.18</b>	<b>80,183.00</b>	<b>434,114.89</b>	<b>641,464.00</b>	<b>962,200.00</b>
<b>Economic Development</b>					
6060 · Economic Developmt Programs	15,921.05	8,333.00	30,209.43	66,664.00	100,000.00
8053 · Market Feasibility Study	4,528.74	8,333.00	4,951.33	66,664.00	100,000.00
<b>Total Economic Development</b>	<b>20,449.79</b>	<b>16,666.00</b>	<b>35,160.76</b>	<b>133,328.00</b>	<b>200,000.00</b>
<b>Communication, Public Affairs, Marketing</b>					
6065 · Events	2,985.78	3,042.00	6,300.39	24,336.00	36,500.00
6068 · CPA&M Programs	19.18	833.00	69.18	6,664.00	10,000.00
6070 · Creative Support	3,800.00	8,958.00	35,200.00	71,664.00	107,500.00
6075 · Marketing Mtls & Promo Items	0.00	4,167.00	760.79	33,336.00	50,000.00
6078 · Advertisement	0.00	10,417.00	906.59	83,336.00	125,000.00
<b>Total Comm., Public Affairs, Marketing</b>	<b>6,804.96</b>	<b>27,417.00</b>	<b>43,236.95</b>	<b>219,336.00</b>	<b>329,000.00</b>



**Hobby Area District**  
**Statement of Sources & Uses - Budget vs Actual**  
**August 2020**

	Aug 20	Budget	Jan - Aug 20	YTD Budget	Annual Budget
<b>Administration</b>					
6112 · Administration Programs	0.00	651.00	65.00	5,208.00	7,815.00
6115 · Meeting Expense	0.00	2,000.00	4,600.33	16,000.00	24,000.00
6120 · Reimbursable Expenses	23.00	1,375.00	269.77	11,000.00	16,500.00
6125 · Postage	60.43	46.00	519.61	368.00	550.00
6130 · Office Supplies	0.00	833.00	2,636.48	6,664.00	10,000.00
6135 · Public Notices, Advertising	9.36	142.00	55.80	1,136.00	1,700.00
6140 · Legal Services	10,352.40	4,583.00	52,995.81	36,664.00	55,000.00
6145 · Audit Services	0.00	3,750.00	13,600.00	30,000.00	45,000.00
6150 · Bookkeeping	1,000.00	1,000.00	7,850.00	8,000.00	12,000.00
6155 · Assessment Billing	2,568.84	3,208.00	25,644.02	25,664.00	38,500.00
6160 · Assessment Database Mgmt.	300.00	367.00	2,400.00	2,936.00	4,400.00
6165 · Office Equipment	749.97	1,250.00	4,296.20	10,000.00	15,000.00
6170 · Insurance	7,530.32	1,250.00	7,930.32	10,000.00	15,000.00
6072 · Office Lease	2,450.00	3,333.00	19,600.00	26,664.00	40,000.00
6073 · Communication & Technologies	897.83	2,862.00	10,312.89	22,902.00	34,350.00
6175 · Other	63.92	125.00	1,148.28	1,000.00	1,500.00
<b>Employee Payroll &amp; Benefits</b>					
6180 · Gross Wages	9,562.50	33,333.00	117,666.48	266,664.00	400,000.00
6181 · Payroll Taxes	731.54	2,550.00	6,035.33	20,400.00	30,600.00
6182 · Payroll Service	-795.27	33.00	4,775.29	264.00	400.00
6183 · Health Insurance	0.00	5,784.00	26,636.45	46,272.00	69,407.00
6184 · Retirement Fund	382.50	95.00	2,681.43	753.00	1,133.00
<b>Total Employee Payroll &amp; Benefits</b>	<b>9,881.27</b>	<b>41,795.00</b>	<b>157,794.98</b>	<b>334,353.00</b>	<b>501,540.00</b>
<b>Total Administration</b>	<b>35,887.34</b>	<b>68,570.00</b>	<b>311,719.49</b>	<b>548,559.00</b>	<b>822,855.00</b>
<b>TOTAL M&amp;O USES OF FUNDS</b>	<b>152,563.78</b>	<b>242,383.00</b>	<b>1,052,907.29</b>	<b>1,939,063.00</b>	<b>2,908,615.00</b>
<b>Other Expense</b>					
9000 · Transfer to Improvement Corp.	0.00	0.00	50,000.00	50,000.00	50,000.00
<b>Total Other Expense</b>	<b>0.00</b>	<b>0.00</b>	<b>50,000.00</b>	<b>50,000.00</b>	<b>50,000.00</b>
<b>EXCESS (DEFICIT) OF SOURCES OVER USES</b>	<b>24,981.13</b>	<b>-79,467.00</b>	<b>291,766.45</b>	<b>-685,735.00</b>	<b>-1,003,615.00</b>
<b>Total Projected Revenue &amp; Reimbursements</b>					<b>1,955,000</b>
<b>Total Projected Uses of Funds</b>					<b>2,958,615</b>
<b>Prior Year Reserves</b>					<b>1,229,955</b>
<b>Projected Year End Cash Reserves</b>					<b>226,340</b>

**Hobby Area District  
Bank Account Registers  
As of October 8, 2020**

<b>Type</b>	<b>Date</b>	<b>Num</b>	<b>Name</b>	<b>Memo</b>	<b>Amount</b>	<b>Balance</b>
<b>Amegy Bank</b>						<b>3,814.88</b>
General Journal	07/15/2020	Payroll	Paychex	Prior Fee Adjustments	-465.40	3,349.48
Transfer	09/17/2020	Trf.	TexSTAR	Transfer from TexSTAR	100,000.00	103,349.48
Check	08/14/2020	3038	Advanced Stores Company Inc	Tax Assessment Refund	-110.29	103,239.19
Check	08/14/2020	3039	Void	Void	0.00	103,239.19
Check	08/14/2020	3040	B & E Apartments LLC	Tax Assessment Refund	-111.97	103,127.22
Check	08/14/2020	3041	Capview Income & Value Fund	Tax Assessment Refund	-237.01	102,890.21
Check	08/14/2020	3042	CCI Hobby I LP	Tax Assessment Refund	-374.25	102,515.96
Check	08/14/2020	3043	Clarke Distributing LLC	Tax Assessment Refund	-158.33	102,357.63
Check	08/14/2020	3044	Comerica Bank	Tax Assessment Refund	-449.21	101,908.42
Check	08/14/2020	3045	Friedkin Realty Hobby Airport	Tax Assessment Refund	-276.19	101,632.23
Check	08/14/2020	3046	Global New Millennium Partners LTI	Tax Assessment Refund	-80.86	101,551.37
Check	08/14/2020	3047	HEB Grocery Company LP	Tax Assessment Refund	-543.09	101,008.28
Check	08/14/2020	3048	Hobby Warehouse Center LLC	Tax Assessment Refund	-1,083.54	99,924.74
Check	08/14/2020	3049	Kainer Export Crating Inc.	Tax Assessment Refund	-26.36	99,898.38
Check	08/14/2020	3050	Kucinski Family Trust	Tax Assessment Refund	-180.70	99,717.68
Check	08/14/2020	3051	Pingree 2000 Real Estate	Tax Assessment Refund	-283.15	99,434.53
Check	08/14/2020	3052	Syndex Corporation	Tax Assessment Refund	-2,700.00	96,734.53
Bill Pmt -Check	08/14/2020	3053	Clark Condon Associates, Inc	Gateway Preliminary Design	-10,595.68	86,138.85
Bill Pmt -Check	08/14/2020	3054	Governmental Financial Reporting	Bookkeeping	-1,034.74	85,104.11
Bill Pmt -Check	08/14/2020	3055	SEAL Security Solutions LLC	Security	-5,766.00	79,338.11
Check	08/14/2020	3056	ARCP MT Houston TX LLC	Tax Assessment Refund	-240.11	79,098.00
General Journal	08/15/2020	Payroll	Paychex	Payroll	-3,210.65	75,887.35
General Journal	08/15/2020	Payroll	Paychex	Payroll Taxes	-1,219.18	74,668.17
General Journal	08/15/2020	Payroll	Paychex	401K & UME	-908.44	73,759.73
General Journal	08/15/2020	Payroll	Paychex	Fee	-483.61	73,276.12
Bill Pmt -Check	08/28/2020	3057	Beth Strobe	August expense report	-127.49	73,148.63
Bill Pmt -Check	08/28/2020	3058	Mister Sweeper LP	Street Sweeping	-3,808.60	69,340.03
Bill Pmt -Check	08/28/2020	3059	Office Systems of Texas	Copier	-99.00	69,241.03
Bill Pmt -Check	08/28/2020	3060	SEAL Security Solutions LLC	Security	-4,952.25	64,288.78
Bill Pmt -Check	08/28/2020	3061	TML Intergovernmental Risk Pool	Insurance	-7,530.32	56,758.46
General Journal	08/31/2020	Payroll	Paychex	Payroll	-3,210.65	53,547.81
General Journal	08/31/2020	Payroll	Paychex	Payroll Taxes	-1,219.18	52,328.63
General Journal	08/31/2020	Payroll	Paychex	401K & UME	-908.44	51,420.19
General Journal	08/31/2020	Payroll	Paychex	Fee	-483.61	50,936.58
Check	09/01/2020	ACH	Guardian	Insurance (Dental, Life, Vision	-33.32	50,903.26
Bill Pmt -Check	09/02/2020	Online	8121 Broadway Interests LLC	Office Rent	-2,450.00	48,453.26
Bill Pmt -Check	09/04/2020	3062	River Oaks Jeep	Lease Agreement-down pymt	-3,000.00	45,453.26
Bill Pmt -Check	09/04/2020	3063	River Oaks Jeep	Lease Agreement-down pymt	-3,000.00	42,453.26
Bill Pmt -Check	09/09/2020	ACH	Amegy Visa Credit Card	Miscellaneous	-4,096.50	38,356.76
General Journal	09/15/2020	Payroll	Paychex	Payroll	-3,930.29	34,426.47
General Journal	09/15/2020	Payroll	Paychex	Payroll Taxes	-1,369.77	33,056.70
General Journal	09/15/2020	Payroll	Paychex	401K & UME	-908.44	32,148.26
General Journal	09/15/2020	Payroll	Paychex	Fee	-524.73	31,623.53
Transfer	09/17/2020	Trf.	TexSTAR	Transfer from TexSTAR	125,000.00	156,623.53
Bill Pmt -Check	09/18/2020	3064	Allen Boone Humphries Robinson	Client: HOB000-01	-8,247.50	148,376.03
Bill Pmt -Check	09/18/2020	3065	Arthur Perez	Computer Maintenance	-437.50	147,938.53
Bill Pmt -Check	09/18/2020	3066	Busy Bee Creatives LLC	Website Maint & Social Media	-3,000.00	144,938.53
Bill Pmt -Check	09/18/2020	3067	Clark Condon Associates, Inc	Gateway Preliminary Design	-15,921.05	129,017.48
Bill Pmt -Check	09/18/2020	3068	Core Logic Safe Rent	Apartment Life Initiatives	-1,657.25	127,360.23
Bill Pmt -Check	09/18/2020	3069	East End District	Graffiti Abatement	-4,371.76	122,988.47
Bill Pmt -Check	09/18/2020	3070	Equi-Tax Inc.	Monthly Assessor Services	-2,868.84	120,119.63
Bill Pmt -Check	09/18/2020	3071	Ev1pro	Photo Coverage for events	-800.00	119,319.63
Bill Pmt -Check	09/18/2020	3072	Governmental Financial Reporting	Bookkeeping	-1,060.43	118,259.20
Bill Pmt -Check	09/18/2020	3073	Great America Financial Services	Copier	-383.26	117,875.94
Bill Pmt -Check	09/18/2020	3074	Hawes Hill & Associates LLC	Admin. Management	-9,101.10	108,774.84

**Hobby Area District  
Bank Account Registers  
As of October 8, 2020**

<b>Type</b>	<b>Date</b>	<b>Num</b>	<b>Name</b>	<b>Memo</b>	<b>Amount</b>	<b>Balance</b>
Bill Pmt -Check	09/18/2020	3075	Houston Business Journal	Annual Subscription	-81.19	108,693.65
Bill Pmt -Check	09/18/2020	3076	McCall Gibson Swedlund Barfoot	Final Audit Billing-YE 12-31-20	-6,000.00	102,693.65
Bill Pmt -Check	09/18/2020	3077	Mister Sweeper LP	Street Sweeping	-3,808.60	98,885.05
Bill Pmt -Check	09/18/2020	3078	NEC - Neon Electric Corporation	Banner sign repair	-4,460.00	94,425.05
Bill Pmt -Check	09/18/2020	3079	Perdue, Brandon, Fielder, Collins	Delinquent Collections	-2,104.90	92,320.15
Bill Pmt -Check	09/18/2020	3080	SEAL Security Solutions LLC	Security	-24,265.25	68,054.90
Bill Pmt -Check	09/18/2020	3081	SMC Logistics	Litter Abatement & Landscape	-35,804.73	32,250.17
Bill Pmt -Check	09/18/2020	3082	Texas Excavation Safety System	Message Fees - Texas811	-337.25	31,912.92
Bill Pmt -Check	09/18/2020	3083	Zaladium Analytics LLC	Monitoring Cameras	-1,700.00	30,212.92
Check	09/21/2020	3084	Astro, Hobby, West Mt. Renal Care	Tax Assessment Refund	-1,477.05	28,735.87
Check	09/21/2020	3085	Verde Communities LLC	Tax Assessment Refund	-15,990.76	12,745.11
Bill Pmt -Check	09/30/2020	3086	Amegy Visa Credit Card	Miscellaneous	-38.76	12,706.35
Bill Pmt -Check	09/30/2020	3087	Beth Strobe	Expense Report	-342.20	12,364.15
Bill Pmt -Check	09/30/2020	3088	Mister Sweeper LP	Street Sweeping	-3,023.25	9,340.90
Transfer	10/07/2020	Trf.	TexSTAR	Transfer from TexSTAR	100,000.00	109,340.90
Bill Pmt -Check	09/30/2020	3089	SEAL Security Solutions LLC	Security	-12,105.50	97,235.40
General Journal	09/30/2020	Payroll	Paychex	Payroll	-4,638.53	92,596.87
General Journal	09/30/2020	Payroll	Paychex	Payroll Taxes	-1,618.51	90,978.36
General Journal	09/30/2020	Payroll	Paychex	401K & UME	-971.05	90,007.31
General Journal	09/30/2020	Payroll	Paychex	Fee	-524.73	89,482.58
Check	10/01/2020	ACH	Guardian	Insurance (Dental, Life, Vision)	-110.89	89,371.69
Bill Pmt -Check	10/01/2020	ACH	8121 Broadway Interests LLC	Office Rent	-2,450.00	86,921.69
Check	10/08/2020	3090	7950 Bellfort LTD	Tax Assessment Refund	-2,354.00	84,567.69
Check	10/08/2020	3091	APT Broadway Village LLC	Tax Assessment Refund	-5,222.17	79,345.52
Check	10/08/2020	3092	First Service Credit Union	Tax Assessment Refund	-16.41	79,329.11
Check	10/08/2020	3093	Lauren Holdings	Tax Assessment Refund	-329.51	78,999.60
Check	10/08/2020	3094	MPT Interest LLC	Tax Assessment Refund	-207.00	78,792.60
Check	10/08/2020	3095	Stiles Properties Braniff Road	Tax Assessment Refund	-245.02	78,547.58
Check	10/08/2020	3096	VLR Texas Properties LLC	Tax Assessment Refund	-53.46	78,494.12
Bill Pmt -Check	10/08/2020	3097	Arthur Perez	Setup Whitelist & repair D. Pei	-525.00	77,969.12
Bill Pmt -Check	10/08/2020	3098	East End District	Field Services - Sept.	-964.23	77,004.89
Bill Pmt -Check	10/08/2020	3099	Equi-Tax Inc.	Monthly Assessor Services	-2,868.84	74,136.05
Bill Pmt -Check	10/08/2020	3100	Governmental Financial Reporting, I	Bookkeeping	-1,052.04	73,084.01
Bill Pmt -Check	10/08/2020	3101	Great America Financial Services	Copier	-383.26	72,700.75
Bill Pmt -Check	10/08/2020	3102	Office Systems of Texas	Copier	-80.02	72,620.73
Bill Pmt -Check	10/08/2020	3103	Tribe Design	Signs & Stickers for Distr. Eve	-1,066.30	71,554.43
Bill Pmt -Check	10/08/2020	3104	Hawes Hill & Associates LLC	Admin. Management	-9,000.00	62,554.43
<b>Total Amegy Bank</b>					<b>58,739.55</b>	<b>62,554.43</b>
<b>Wells Fargo Bank</b>						<b>168,778.66</b>
Deposit	07/31/2020	Dep.	Tax Revenue	July Tax Revenue	14,320.84	183,099.50
Deposit	07/31/2020	Dep.	Interest	July Interest	23.73	183,123.23
Debit	08/11/2020	Debit	Wells Fargo Bank	Service Charge	-35.92	183,087.31
Deposit	08/31/2020	Dep.	Tax Revenue	August Tax Revenue	14,384.37	197,471.68
Deposit	08/31/2020	Dep.	Interest	August Interest	25.70	197,497.38
Transfer	09/30/2020	Trf.	TexSTAR	Transfer to TexSTAR	-195,000.00	2,497.38
<b>Total Wells Fargo Bank</b>					<b>-166,281.28</b>	<b>2,497.38</b>
<b>Plains State Bank - CD</b>						<b>255,092.37</b>
Deposit	07/14/2020	Dep.	Interest	Interest	201.56	255,293.93
					201.56	<b>255,293.93</b>
<b>Plus4 Credit Union - CD</b>						<b>5.34</b>
<b>Total Plus4 Credit Union</b>					<b>0.00</b>	<b>5.34</b>

**Hobby Area District  
Bank Account Registers  
As of October 8, 2020**

<i>Type</i>	<i>Date</i>	<i>Num</i>	<i>Name</i>	<i>Memo</i>	<i>Amount</i>	<i>Balance</i>
<b>TexSTAR-Operating</b>						<b>1,824,337.29</b>
Deposit	07/31/2020	Dep.	Interest	July Interest	334.64	1,824,671.93
Transfer	08/13/2020	Trf.	Amegy	Transfer to Amegy	-100,000.00	1,724,671.93
Deposit	08/31/2020	Dep.	Interest	August Interest	247.53	1,724,919.46
Transfer	09/17/2020	Trf.	Amegy	Transfer to Amegy	-125,000.00	1,599,919.46
Transfer	09/30/2020	Trf.	Wells Fargo Bank	Transfer from Wells Fargo	195,000.00	1,794,919.46
Transfer	10/07/2020	Trf.	Amegy	Transfer to Amegy	-100,000.00	1,694,919.46
Total TexSTAR-Operating					-129,417.83	<b>1,694,919.46</b>
<b>TOTAL</b>					<b>-236,959.56</b>	<b>2,015,270.54</b>

**Hobby Area Management District**  
**Investment Report**  
**For the Period 1/1/2020 through 3/31/2020**

	Purchase Date	Maturity Date	Yield	Beginning		Changes		Ending	
				Book Val.	Market Val.	Increase	Decrease	Book Val.	Market Val.
<i>General Fund:</i>									
Plains State Bank - CD	07/14/19	07/14/20	2.000	252,492.17	252,492.17	1,296.77		253,788.94	253,788.94
Plus4 Credit Union - CD	N/A	N/A	N/A	5.34	5.34			5.34	5.34
TexSTAR	Varies	Varies	0.550	863,471.23	863,471.23	1,184,282.62	475,000.00	1,572,753.85	1,572,753.85
Totals				1,115,968.74	1,115,968.74	1,185,579.39	475,000.00	1,826,548.13	1,826,548.13

The investment portfolio complies with the investment strategy expressed in the District's investment policy as well as relevant provisions of Chapter 2256, Government Code.

  
 Bookkeeper - Governmental Financial Reporting, LLC

Date: 08-Apr-20

**Hobby Area Management District**  
**Investment Report**  
**For the Period 4/1/2020 through 6/30/2020**

	Purchase Date	Maturity Date	Yield	Beginning		Changes		Ending	
				Book Val.	Market Val.	Increase	Decrease	Book Val.	Market Val.
<i>General Fund:</i>									
Plains State Bank - CD	07/14/19	07/14/20	2.000	253,788.94	253,788.94	1,303.43		255,092.37	255,092.37
Plus4 Credit Union - CD	N/A	N/A	N/A	5.34	5.34			5.34	5.34
TexSTAR	Varies	Varies	0.240	1,572,753.85	1,572,753.85	751,583.44	300,000.00	2,024,337.29	2,024,337.29
Totals				1,826,548.13	1,826,548.13	752,886.87	300,000.00	2,279,435.00	2,279,435.00

The investment portfolio complies with the investment strategy expressed in the District's investment policy as well as relevant provisions of Chapter 2256, Government Code.

  
 Bookkeeper - Governmental Financial Reporting, LLC

Date: 10-Jul-20

# CLARK CONDON

10401 STELLA LINK ROAD  
HOUSTON, TEXAS 77025  
Phone 713.871.1414 Fax 713.871.0888  
CLARKCONDON.COM

Beth Strobe  
Hobby Area Management District  
8121 Broadway, Suite 199  
Houston, TX 77051

Date: July 31, 2020  
Invoice number: 46687  
Project Number: 120-090

## Hobby Area Gateway Preliminary Design

Professional Services for the Period: 7/1/2020 to 7/31/2020

Phase	Phase Fee	% Complete	Fee Earned	Prior Billing	Current Fee
Preliminary Design	\$35,000.00	30.00	\$10,500.00	\$0.00	\$10,500.00
	\$35,000.00	30.00	\$10,500.00	\$0.00	\$10,500.00

### Reimbursables

PHASE SUMMARY:	
Phase Maximum	\$3,000.00
Previous Billings	\$0.00
Current Billing	\$95.68
Balance After This Invoice	\$2,904.32

In-House Printing	\$51.00
Miles	\$32.20
Subtotal:	\$83.20
Expense Fee	\$12.48
Total Reimbursables	\$95.68
<b>TOTAL AMOUNT DUE</b>	<b>\$10,595.68</b>

## Activity Summary Report

Date Range: 06/30/2020 to 07/30/2020

Project / Media / Page Size / Cost	Qty	Total Units / Sq Ft	Total Cost
120-090 - Hobby Area Gateway Preliminary Design			
Color Laser -cost each			
11.00x17.00			
Unit Cost: \$3.00	17.00	34.00	\$51.00
<b>Total for 120-090 - Hobby Area Gateway Preliminary Design</b>	<b>17.00</b>		<b>\$51.00</b>

## Governmental Financial Reporting, LLC

1525 Lakeville Drive, Suite 121  
Kingwood, TX 77339  
(281) 348-9151  
FAX (281) 348-9199

8/5/2020

Hobby Area District  
8121 Broadway Blvd, Ste 199  
Houston, TX 77061

For Professional Services Rendered

Bookkeeping services provided during July 2020 for the month of June 2020	1,000.00
Postage and Deliveries	34.74
Mileage - No July Board Meeting	0.00
	<b>\$1,034.74</b>



## SEAL Security Solutions LLC

1525 Blalock Road  
Houston, TX 77080-7318  
www.SEALSecurity.com  
713-979-2388  
TX DPS Lic. #C15942

## Invoice

Date	Invoice #
8/3/2020	48708

Bill To
Hobby Management District 8121 Broadway, Suite 199 Houston, TX 77061

Description	Hours	Rate/ Hour	Amount	Terms
				Net 30
Commissioned Security Officer with Vehicle and K-9 Patrol Period 07/27/2020 through 08/02/2020  Patrols are billed every Monday for the hours patrolled the week preceding the above invoice date.  This invoice is Monday through Sunday inclusive.	186	31.00	5,766.00	
				Sales Tax (8.25%) \$0.00
<b>Thank you for allowing us to earn your business.</b>	<b>Total</b>		<b>\$5,766.00</b>	

NOTE: A 3% convenience fee will be charged on all payments made by credit card.





**Equi-Tax Inc.**  
Ad Valorem Tax Assessors / Collectors

www.equitaxinc.com

17111 Rolling Creek Drive, Suite 200, Houston, Texas 77090  
P. O. Box 73109, Houston, Texas 77273  
Customer Service 281.444.3946 fax 281.440.8304

6/23/2020

KAINER EXPT CRATING INC  
PO BOX 266969

HOUSTON, TX 77207

HOBBY AREA DISTRICT  
ACCOUNT NUMBER: R000200470 / 910620310050005  
LEGAL DESCRIPTION: LTS 5 & 6 & TR 4B W 1/2 OF LT BLK 5 DIXIE ACRES  
SITUS: 6820 LINDBERGH ST  
YEAR: 2018 DATE PROCESSED: 6/23/2020

**NOTICE OF CHANGE IN TAX LIABILITY**

We have been notified by the Appraisal District of a change in the appraisal of your property that has resulted in a change in you tax liability for the 2018 tax year.

The explanation of the change is:

- |  |   |
|--|---|
| <input type="checkbox"/> Decrease in Appraised Value | <input type="checkbox"/> Account Prorated                         |
| <input type="checkbox"/> Exemption(s) Added          | <input type="checkbox"/> Account Deleted                          |
| <input type="checkbox"/> Homestead                   | <input type="checkbox"/> Rendition Penalty Waived                 |
| <input type="checkbox"/> Over 65                     | <input type="checkbox"/> Other: _____                             |
| <input type="checkbox"/> Disabled Person             |   |
| <input type="checkbox"/> Disabled Veteran            | <input checked="" type="checkbox"/> Lawsuit Cause No.: 2018-72266 |

This action has resulted in a decrease in the amount you owe. Accordingly, we are issuing you a refund in the amount of \$26.36.

Note: Questions regarding the changes in value should be directed to the Appraisal District.

If you need more information, call Customer Service at 281.444.3946.



**Equi-Tax Inc.**  
Ad Valorem Tax Assessors / Collectors

www.equitaxinc.com

17111 Rolling Creek Drive, Suite 200, Houston, Texas 77090  
P. O. Box 73109, Houston, Texas 77273  
Customer Service 281.444.3946 fax 281.440.8304

6/23/2020

HOBBY WAREHOUSE CENTER LLC  
8416 S BREEZE DR STE 1E  
HOUSTON, TX 77071-1922

HOBBY AREA DISTRICT  
ACCOUNT NUMBER: R000199957 / 910342030030170  
LEGAL DESCRIPTION: LT 170 SOUTH HOUSTON GARDENS SEC 6  
SITUS: 8501 MOSLEY RD  
YEAR: 2019 DATE PROCESSED: 6/23/2020

**NOTICE OF CHANGE IN TAX LIABILITY**

We have been notified by the Appraisal District of a change in the appraisal of your property that has resulted in a change in you tax liability for the 2019 tax year.

The explanation of the change is:

- |  |  |
|--|--|
| <input type="checkbox"/> Decrease in Appraised Value | <input type="checkbox"/> Account Prorated                            |
| <input type="checkbox"/> Exemption(s) Added          | <input type="checkbox"/> Account Deleted                             |
| <input type="checkbox"/> Homestead                   | <input type="checkbox"/> Rendition Penalty Waived                    |
| <input type="checkbox"/> Over 65                     | <input type="checkbox"/> Other: _____                                |
| <input type="checkbox"/> Disabled Person             |  |
| <input type="checkbox"/> Disabled Veteran            | <input checked="" type="checkbox"/> Lawsuit Cause No.: 101-19-001843 |

This action has resulted in a decrease in the amount you owe. Accordingly, we are issuing you a refund in the amount of \$1,083.54.

Note: Questions regarding the changes in value should be directed to the Appraisal District.

If you need more information, call Customer Service at 281.444.3946.



**Equi-Tax Inc.**  
Ad Valorem Tax Assessors / Collectors

www.equitaxinc.com

17111 Rolling Creek Drive, Suite 200, Houston, Texas 77090  
P. O. Box 73109, Houston, Texas 77273  
Customer Service 281.444.3946 fax 281.440.8304

7/6/2020

B & E APARTMENTS LLC  
100 GLENBOROUGH DR STE 1000  
HOUSTON, TX 77067

HOBBY AREA DISTRICT  
ACCOUNT NUMBER: R000201155 / 911182750010002  
LEGAL DESCRIPTION: RES B BLK 1 HOBBY HOSPITALITY CENTER  
SITUS: 9009 AIRPORT BLVD  
YEAR: 2019 DATE PROCESSED: 7/6/2020

**NOTICE OF CHANGE IN TAX LIABILITY**

We have been notified by the Appraisal District of a change in the appraisal of your property that has resulted in a change in you tax liability for the 2019 tax year.

The explanation of the change is:

- |  |  |
|--|--|
| <input type="checkbox"/> Decrease in Appraised Value | <input type="checkbox"/> Account Prorated                            |
| <input type="checkbox"/> Exemption(s) Added          | <input type="checkbox"/> Account Deleted                             |
| <input type="checkbox"/> Homestead                   | <input type="checkbox"/> Rendition Penalty Waived                    |
| <input type="checkbox"/> Over 65                     | <input type="checkbox"/> Other: _____                                |
| <input type="checkbox"/> Disabled Person             |  |
| <input type="checkbox"/> Disabled Veteran            | <input checked="" type="checkbox"/> Lawsuit Cause No.: 101-19-001162 |

This action has resulted in a decrease in the amount you owe. Accordingly, we are issuing you a refund in the amount of \$111.97.

Note: Questions regarding the changes in value should be directed to the Appraisal District.

If you need more information, call Customer Service at 281.444.3946.



**Equi-Tax Inc.**  
Ad Valorem Tax Assessors / Collectors

www.equitaxinc.com

17111 Rolling Creek Drive, Suite 200, Houston, Texas 77090  
P. O. Box 73109, Houston, Texas 77273  
Customer Service 281.444.3946 fax 281.440.8304

7/23/2020

H E Butt Grocery Co as Lessee  
c/o Popp Hutcheson PLLC  
1301 S MoPac Expressway Ste 430  
Austin, TX 78746

HOBBY AREA DISTRICT  
ACCOUNT NUMBER: R000201188 / 91119800010001  
LEGAL DESCRIPTION: RES A BLK 1 BELLFORT CROSSING  
SITUS: 7994 BELLFORT ST  
YEAR: 2019 DATE PROCESSED: 7/23/2020

**NOTICE OF CHANGE IN TAX LIABILITY**

We have been notified by the Appraisal District of a change in the appraisal of your property that has resulted in a change in you tax liability for the 2019 tax year.

The explanation of the change is:

- |  |   |
|--|---|
| <input type="checkbox"/> Decrease in Appraised Value | <input type="checkbox"/> Account Prorated                         |
| <input type="checkbox"/> Exemption(s) Added          | <input type="checkbox"/> Account Deleted                          |
| <input type="checkbox"/> Homestead                   | <input type="checkbox"/> Rendition Penalty Waived                 |
| <input type="checkbox"/> Over 65                     | <input type="checkbox"/> Other: _____                             |
| <input type="checkbox"/> Disabled Person             |   |
| <input type="checkbox"/> Disabled Veteran            | <input checked="" type="checkbox"/> Lawsuit Cause No.: 2019-77449 |

This action has resulted in a decrease in the amount you owe. Accordingly, we are issuing you a refund in the amount of \$543.09.

Note: Questions regarding the changes in value should be directed to the Appraisal District.

If you need more information, call Customer Service at 281.444.3946.





**Equi-Tax Inc.**  
Ad Valorem Tax Assessors / Collectors

www.equitaxinc.com

17111 Rolling Creek Drive, Suite 200, Houston, Texas 77090  
P. O. Box 73109, Houston, Texas 77273  
Customer Service 281.444.3946 fax 281.440.8304

6/23/2020

CCI HOBBY I LP  
800 BRAZOS ST STE 600  
AUSTIN, TX 78701-2770

HOBBY AREA DISTRICT  
ACCOUNT NUMBER: R000199891 / 910342030020099  
LEGAL DESCRIPTION: LT 99 & TR 1A GULF GARDEN APARTMENTS R/P SOUTH HOUSTON GARDENS SEC 6  
SITUS: 7901 HANSEN RD  
YEAR: 2019 DATE PROCESSED: 6/23/2020

**NOTICE OF CHANGE IN TAX LIABILITY**

We have been notified by the Appraisal District of a change in the appraisal of your property that has resulted in a change in you tax liability for the 2019 tax year.

The explanation of the change is:

- |  |   |
|--|---|
| <input type="checkbox"/> Decrease in Appraised Value | <input type="checkbox"/> Account Prorated                         |
| <input type="checkbox"/> Exemption(s) Added          | <input type="checkbox"/> Account Deleted                          |
| <input type="checkbox"/> Homestead                   | <input type="checkbox"/> Rendition Penalty Waived                 |
| <input type="checkbox"/> Over 65                     | <input type="checkbox"/> Other: _____                             |
| <input type="checkbox"/> Disabled Person             |   |
| <input type="checkbox"/> Disabled Veteran            | <input checked="" type="checkbox"/> Lawsuit Cause No.: 2019-60952 |

This action has resulted in a decrease in the amount you owe. Accordingly, we are issuing you a refund in the amount of \$374.25.

Note: Questions regarding the changes in value should be directed to the Appraisal District.

If you need more information, call Customer Service at 281.444.3946.



**Equi-Tax Inc.**  
Ad Valorem Tax Assessors / Collectors

www.equitaxinc.com

17111 Rolling Creek Drive, Suite 200, Houston, Texas 77090  
P. O. Box 73109, Houston, Texas 77273  
Customer Service 281.444.3946 fax 281.440.8304

6/23/2020

ARCP MT HOUSTON TX LLC  
c/o Caroline Dobbs  
5780 Fleet Street, Ste 300  
Carlsbad, CA 92008  
HOBBY AREA DISTRICT  
ACCOUNT NUMBER: R000201243 / 911260630010010  
LEGAL DESCRIPTION: RES E1 BLK 11-45 AND ALMEDA SHOPPING CENTER SEC 1  
SITUS: 10009 ALMEDA GENOA RD  
YEAR: 2019 DATE PROCESSED: 6/23/2020

**NOTICE OF CHANGE IN TAX LIABILITY**

We have been notified by the Appraisal District of a change in the appraisal of your property that has resulted in a change in you tax liability for the 2019 tax year.

The explanation of the change is:

- |  |   |
|--|---|
| <input type="checkbox"/> Decrease in Appraised Value | <input type="checkbox"/> Account Prorated                         |
| <input type="checkbox"/> Exemption(s) Added          | <input type="checkbox"/> Account Deleted                          |
| <input type="checkbox"/> Homestead                   | <input type="checkbox"/> Rendition Penalty Waived                 |
| <input type="checkbox"/> Over 65                     | <input type="checkbox"/> Other: _____                             |
| <input type="checkbox"/> Disabled Person             |   |
| <input type="checkbox"/> Disabled Veteran            | <input checked="" type="checkbox"/> Lawsuit Cause No.: 2019-66230 |

This action has resulted in a decrease in the amount you owe. Accordingly, we are issuing you a refund in the amount of \$240.11.

Note: Questions regarding the changes in value should be directed to the Appraisal District.

If you need more information, call Customer Service at 281.444.3946.



**Equi-Tax Inc.**  
Ad Valorem Tax Assessors / Collectors

www.equitaxinc.com

17111 Rolling Creek Drive, Suite 200, Houston, Texas 77090  
P. O. Box 73109, Houston, Texas 77273  
Customer Service 281.444.3946 fax 281.440.8304

6/23/2020

CLARKE DISTRIBUTING LLC  
8555 W MONROE RD  
HOUSTON, TX 77061

HOBBY AREA DISTRICT  
ACCOUNT NUMBER: R000199793 / 910342030010010  
LEGAL DESCRIPTION: TR 10 S 266 FT OF W 325 FT OF LT 10 SOUTH HOUSTON GARDENS SEC 6  
SITUS:  
YEAR: 2017 DATE PROCESSED: 6/23/2020

**NOTICE OF CHANGE IN TAX LIABILITY**

We have been notified by the Appraisal District of a change in the appraisal of your property that has resulted in a change in you tax liability for the 2017 tax year.

The explanation of the change is:

- |  |   |
|--|---|
| <input type="checkbox"/> Decrease in Appraised Value | <input type="checkbox"/> Account Prorated                         |
| <input type="checkbox"/> Exemption(s) Added          | <input type="checkbox"/> Account Deleted                          |
| <input type="checkbox"/> Homestead                   | <input type="checkbox"/> Rendition Penalty Waived                 |
| <input type="checkbox"/> Over 65                     | <input type="checkbox"/> Other: _____                             |
| <input type="checkbox"/> Disabled Person             |   |
| <input type="checkbox"/> Disabled Veteran            | <input checked="" type="checkbox"/> Lawsuit Cause No.: 2017-69461 |

This action has resulted in a decrease in the amount you owe. Accordingly, we are issuing you a refund in the amount of \$47.64.

Note: Questions regarding the changes in value should be directed to the Appraisal District.

If you need more information, call Customer Service at 281.444.3946.



**Equi-Tax Inc.**  
Ad Valorem Tax Assessors / Collectors

www.equitaxinc.com

17111 Rolling Creek Drive, Suite 200, Houston, Texas 77090  
P. O. Box 73109, Houston, Texas 77273  
Customer Service 281.444.3946 fax 281.440.8304

6/23/2020

CLARKE DISTRIBUTING LLC  
8555 W MONROE RD  
HOUSTON, TX 77061

HOBBY AREA DISTRICT  
ACCOUNT NUMBER: R000199793 / 910342030010010  
LEGAL DESCRIPTION: TR 10 S 266 FT OF W 325 FT OF LT 10 SOUTH HOUSTON GARDENS SEC 6  
SITUS: 8555 W MONROE RD  
YEAR: 2018 DATE PROCESSED: 6/23/2020

**NOTICE OF CHANGE IN TAX LIABILITY**

We have been notified by the Appraisal District of a change in the appraisal of your property that has resulted in a change in you tax liability for the 2018 tax year.

The explanation of the change is:

- |  |   |
|--|---|
| <input type="checkbox"/> Decrease in Appraised Value | <input type="checkbox"/> Account Prorated                         |
| <input type="checkbox"/> Exemption(s) Added          | <input type="checkbox"/> Account Deleted                          |
| <input type="checkbox"/> Homestead                   | <input type="checkbox"/> Rendition Penalty Waived                 |
| <input type="checkbox"/> Over 65                     | <input type="checkbox"/> Other: _____                             |
| <input type="checkbox"/> Disabled Person             |   |
| <input type="checkbox"/> Disabled Veteran            | <input checked="" type="checkbox"/> Lawsuit Cause No.: 2018-71785 |

This action has resulted in a decrease in the amount you owe. Accordingly, we are issuing you a refund in the amount of \$47.69.

Note: Questions regarding the changes in value should be directed to the Appraisal District.

If you need more information, call Customer Service at 281.444.3946.



**Equi-Tax Inc.**  
Ad Valorem Tax Assessors / Collectors

www.equitaxinc.com

17111 Rolling Creek Drive, Suite 200, Houston, Texas 77090  
P. O. Box 73109, Houston, Texas 77273  
Customer Service 281.444.3946 fax 281.440.8304

6/23/2020

CLARKE DISTRIBUTING LLC  
8555 W MONROE RD

HOUSTON, TX 77061-4807

HOBBY AREA DISTRICT  
ACCOUNT NUMBER: R000199793 / 910342030010010  
LEGAL DESCRIPTION: TR 10 S 266 FT OF W 325 FT OF LT 10 SOUTH HOUSTON GARDENS SEC 6  
SITUS: 8555 W MONROE RD  
YEAR: 2019

DATE PROCESSED: 6/23/2020

**NOTICE OF CHANGE IN TAX LIABILITY**

We have been notified by the Appraisal District of a change in the appraisal of your property that has resulted in a change in your tax liability for the 2019 tax year.

The explanation of the change is:

- |  |   |
|--|---|
| <input type="checkbox"/> Decrease in Appraised Value | <input type="checkbox"/> Account Prorated                         |
| <input type="checkbox"/> Exemption(s) Added          | <input type="checkbox"/> Account Deleted                          |
| <input type="checkbox"/> Homestead                   | <input type="checkbox"/> Rendition Penalty Waived                 |
| <input type="checkbox"/> Over 65                     | <input type="checkbox"/> Other: _____                             |
| <input type="checkbox"/> Disabled Person             |   |
| <input type="checkbox"/> Disabled Veteran            | <input checked="" type="checkbox"/> Lawsuit Cause No.: 2019-67999 |

This action has resulted in a decrease in the amount you owe. Accordingly, we are issuing you a refund in the amount of \$63.00.

Note: Questions regarding the changes in value should be directed to the Appraisal District.

If you need more information, call Customer Service at 281.444.3946.



**Equi-Tax Inc.**  
Ad Valorem Tax Assessors / Collectors

www.equitaxinc.com

17111 Rolling Creek Drive, Suite 200, Houston, Texas 77090  
P. O. Box 73109, Houston, Texas 77273  
Customer Service 281.444.3946 fax 281.440.8304

6/23/2020

ADVANCE STORES COMPANY INC 8094  
PO BOX 2710  
ROANOKE, VA 24001-2710

HOBBY AREA DISTRICT  
ACCOUNT NUMBER: R000201280 / 911297850010001  
LEGAL DESCRIPTION: RES A BLK 1 IH 45 AND ALMEDA SHOPPING CENTER SEC 3  
SITUS: 9911 ALMEDA GENOA RD  
YEAR: 2019

DATE PROCESSED: 6/23/2020

**NOTICE OF CHANGE IN TAX LIABILITY**

We have been notified by the Appraisal District of a change in the appraisal of your property that has resulted in a change in your tax liability for the 2019 tax year.

The explanation of the change is:

- |  |   |
|--|---|
| <input type="checkbox"/> Decrease in Appraised Value | <input type="checkbox"/> Account Prorated                         |
| <input type="checkbox"/> Exemption(s) Added          | <input type="checkbox"/> Account Deleted                          |
| <input type="checkbox"/> Homestead                   | <input type="checkbox"/> Rendition Penalty Waived                 |
| <input type="checkbox"/> Over 65                     | <input type="checkbox"/> Other: _____                             |
| <input type="checkbox"/> Disabled Person             |   |
| <input type="checkbox"/> Disabled Veteran            | <input checked="" type="checkbox"/> Lawsuit Cause No.: 2019-66785 |

This action has resulted in a decrease in the amount you owe. Accordingly, we are issuing you a refund in the amount of \$110.29.

Note: Questions regarding the changes in value should be directed to the Appraisal District.

If you need more information, call Customer Service at 281.444.3946.



**Equi-Tax Inc.**  
Ad Valorem Tax Assessors / Collectors

www.equitaxinc.com

17111 Rolling Creek Drive, Suite 200, Houston, Texas 77090  
P. O. Box 73109, Houston, Texas 77273  
Customer Service 281.444.3946 fax 281.440.8304

6/23/2020

COMERICA BANK  
2 CORPORATE DR STE 300  
SOUTHFIELD, MI 48076-3759

HOBBY AREA DISTRICT  
ACCOUNT NUMBER: R000199945 / 910342030030123  
LEGAL DESCRIPTION: TRS 123 & 123C SOUTH HOUSTON GARDENS SEC 6  
SITUS: 9100 AIRPORT BLVD  
YEAR: 2019

DATE PROCESSED: 6/23/2020

**NOTICE OF CHANGE IN TAX LIABILITY**

We have been notified by the Appraisal District of a change in the appraisal of your property that has resulted in a change in your tax liability for the 2019 tax year.

The explanation of the change is:

- |  |   |
|--|---|
| <input type="checkbox"/> Decrease in Appraised Value | <input type="checkbox"/> Account Prorated                         |
| <input type="checkbox"/> Exemption(s) Added          | <input type="checkbox"/> Account Deleted                          |
| <input type="checkbox"/> Homestead                   | <input type="checkbox"/> Rendition Penalty Waived                 |
| <input type="checkbox"/> Over 65                     | <input type="checkbox"/> Other: _____                             |
| <input type="checkbox"/> Disabled Person             |   |
| <input type="checkbox"/> Disabled Veteran            | <input checked="" type="checkbox"/> Lawsuit Cause No.: 2019-65864 |

This action has resulted in a decrease in the amount you owe. Accordingly, we are issuing you a refund in the amount of \$449.21.

Note: Questions regarding the changes in value should be directed to the Appraisal District.

If you need more information, call Customer Service at 281.444.3946.



**Equi-Tax Inc.**  
Ad Valorem Tax Assessors / Collectors

www.equitaxinc.com

17111 Rolling Creek Drive, Suite 200, Houston, Texas 77090  
P. O. Box 73109, Houston, Texas 77273  
Customer Service 281.444.3946 fax 281.440.8304

6/23/2020

CAPVIEW INCOME & VALUE FUND IV LP  
PO BOX 460189  
HOUSTON, TX 77056-8189

HOBBY AREA DISTRICT  
ACCOUNT NUMBER: R000201275 / 911295780010002  
LEGAL DESCRIPTION: RES A-1 BLK 1 ROWLETT AT GULF FREEWAY  
SITUS: 11408 GULF FWY  
YEAR: 2019

DATE PROCESSED: 6/23/2020

**NOTICE OF CHANGE IN TAX LIABILITY**

We have been notified by the Appraisal District of a change in the appraisal of your property that has resulted in a change in your tax liability for the 2019 tax year.

The explanation of the change is:

- |  |   |
|--|---|
| <input type="checkbox"/> Decrease in Appraised Value | <input type="checkbox"/> Account Prorated                         |
| <input type="checkbox"/> Exemption(s) Added          | <input type="checkbox"/> Account Deleted                          |
| <input type="checkbox"/> Homestead                   | <input type="checkbox"/> Rendition Penalty Waived                 |
| <input type="checkbox"/> Over 65                     | <input type="checkbox"/> Other: _____                             |
| <input type="checkbox"/> Disabled Person             |   |
| <input type="checkbox"/> Disabled Veteran            | <input checked="" type="checkbox"/> Lawsuit Cause No.: 2019-66436 |

This action has resulted in a decrease in the amount you owe. Accordingly, we are issuing you a refund in the amount of \$237.01.

Note: Questions regarding the changes in value should be directed to the Appraisal District.

If you need more information, call Customer Service at 281.444.3946.





**Equi-Tax Inc.**  
Ad Valorem Tax Assessors / Collectors

www.equitaxinc.com

17111 Rolling Creek Drive, Suite 200, Houston, Texas 77090  
P. O. Box 73109, Houston, Texas 77273  
Customer Service 281.444.3946 fax 281.440.8304

6/23/2020

PINGREE 2000 REAL ESTATE HOLDINGS LLC  
600 CORPORATE PARK DR  
SAINT LOUIS, MO 63105-4204

HOBBY AREA DISTRICT

ACCOUNT NUMBER: R000201099 / 910963210000004  
LEGAL DESCRIPTION: TRS 1A & 3A BLK 5 CENTRAL INDUSTRIAL PARK 2 R/P  
SITUS: 7040 AIRPORT BLVD  
YEAR: 2019 DATE PROCESSED: 6/23/2020

**NOTICE OF CHANGE IN TAX LIABILITY**

We have been notified by the Appraisal District of a change in the appraisal of your property that has resulted in a change in your tax liability for the 2019 tax year.

The explanation of the change is:

<input type="checkbox"/> Decrease in Appraised Value	<input type="checkbox"/> Account Prorated
<input type="checkbox"/> Exemption(s) Added	<input type="checkbox"/> Account Deleted
<input type="checkbox"/> Homestead	<input type="checkbox"/> Rendition Penalty Waived
<input type="checkbox"/> Over 65	<input type="checkbox"/> Other: _____
<input type="checkbox"/> Disabled Person	
<input type="checkbox"/> Disabled Veteran	<input checked="" type="checkbox"/> Lawsuit Cause No.: 2019-70056

This action has resulted in a decrease in the amount you owe. Accordingly, we are issuing you a refund in the amount of \$283.15.

Note: Questions regarding the changes in value should be directed to the Appraisal District.

If you need more information, call Customer Service at 281.444.3946.



**Equi-Tax Inc.**  
Ad Valorem Tax Assessors / Collectors

www.equitaxinc.com

17111 Rolling Creek Drive, Suite 200, Houston, Texas 77090  
P. O. Box 73109, Houston, Texas 77273  
Customer Service 281.444.3946 fax 281.440.8304

6/23/2020

KUCINSKI FAMILY TRUST

c/o Ryan Law Firm PLLC  
P O Box 802882  
Dallas, TX 75380  
HOBBY AREA DISTRICT  
ACCOUNT NUMBER: R000201283 / 911297850010004  
LEGAL DESCRIPTION: RES D BLK 1 IH 45 AND ALMEDA SHOPPING CENTER SEC 3  
SITUS: 9997 ALMEDA GENOA RD  
YEAR: 2019 DATE PROCESSED: 6/23/2020

**NOTICE OF CHANGE IN TAX LIABILITY**

We have been notified by the Appraisal District of a change in the appraisal of your property that has resulted in a change in your tax liability for the 2019 tax year.

The explanation of the change is:

<input type="checkbox"/> Decrease in Appraised Value	<input type="checkbox"/> Account Prorated
<input type="checkbox"/> Exemption(s) Added	<input type="checkbox"/> Account Deleted
<input type="checkbox"/> Homestead	<input type="checkbox"/> Rendition Penalty Waived
<input type="checkbox"/> Over 65	<input type="checkbox"/> Other: _____
<input type="checkbox"/> Disabled Person	
<input type="checkbox"/> Disabled Veteran	<input checked="" type="checkbox"/> Lawsuit Cause No.: 2019-65864

This action has resulted in a decrease in the amount you owe. Accordingly, we are issuing you a refund in the amount of \$180.70.

Note: Questions regarding the changes in value should be directed to the Appraisal District.

If you need more information, call Customer Service at 281.444.3946.



**Equi-Tax Inc.**  
Ad Valorem Tax Assessors / Collectors

www.equitaxinc.com

17111 Rolling Creek Drive, Suite 200, Houston, Texas 77090  
P. O. Box 73109, Houston, Texas 77273  
Customer Service 281.444.3946 fax 281.440.8304

7/23/2020

GLOBAL NEW MILLENNIUM PARTNERS LTD  
4415 HIGHWAY 6 SOUTH  
SUGAR LAND, TX 77478-4476

HOBBY AREA DISTRICT

ACCOUNT NUMBER: R000200065 / 910402390000005  
LEGAL DESCRIPTION: TR 34D-1 ABST 27 J R HARRIS  
SITUS: 7806 BELLFORT ST  
YEAR: 2019 DATE PROCESSED: 7/23/2020

**NOTICE OF CHANGE IN TAX LIABILITY**

We have been notified by the Appraisal District of a change in the appraisal of your property that has resulted in a change in your tax liability for the 2019 tax year.

The explanation of the change is:

<input type="checkbox"/> Decrease in Appraised Value	<input type="checkbox"/> Account Prorated
<input type="checkbox"/> Exemption(s) Added	<input type="checkbox"/> Account Deleted
<input type="checkbox"/> Homestead	<input type="checkbox"/> Rendition Penalty Waived
<input type="checkbox"/> Over 65	<input type="checkbox"/> Other: _____
<input type="checkbox"/> Disabled Person	
<input type="checkbox"/> Disabled Veteran	<input checked="" type="checkbox"/> Lawsuit Cause No.: 2019-66176

This action has resulted in a decrease in the amount you owe. Accordingly, we are issuing you a refund in the amount of \$80.86.

Note: Questions regarding the changes in value should be directed to the Appraisal District.

If you need more information, call Customer Service at 281.444.3946.



**Equi-Tax Inc.**  
Ad Valorem Tax Assessors / Collectors

www.equitaxinc.com

17111 Rolling Creek Drive, Suite 200, Houston, Texas 77090  
P. O. Box 73109, Houston, Texas 77273  
Customer Service 281.444.3946 fax 281.440.8304

7/23/2020

FRIEDKIN REALTY HOBBY AIRPORT

1375 ENCLAVE PKWY  
HOUSTON, TX 77077-2026

HOBBY AREA DISTRICT

ACCOUNT NUMBER: R000200215 / 910432280000073  
LEGAL DESCRIPTION: TRS 2 3 & 4 (IMPROVEMENT ONLY) (LAND\*043228000015) ABST 562  
P MAHAN  
SITUS: 8602 NELMS  
YEAR: 2019 DATE PROCESSED: 7/23/2020

**NOTICE OF CHANGE IN TAX LIABILITY**

We have been notified by the Appraisal District of a change in the appraisal of your property that has resulted in a change in your tax liability for the 2019 tax year.

The explanation of the change is:

<input type="checkbox"/> Decrease in Appraised Value	<input type="checkbox"/> Account Prorated
<input type="checkbox"/> Exemption(s) Added	<input type="checkbox"/> Account Deleted
<input type="checkbox"/> Homestead	<input type="checkbox"/> Rendition Penalty Waived
<input type="checkbox"/> Over 65	<input type="checkbox"/> Other: _____
<input type="checkbox"/> Disabled Person	
<input type="checkbox"/> Disabled Veteran	<input checked="" type="checkbox"/> Lawsuit Cause No.: 2019-65785

This action has resulted in a decrease in the amount you owe. Accordingly, we are issuing you a refund in the amount of \$276.19.

Note: Questions regarding the changes in value should be directed to the Appraisal District.

If you need more information, call Customer Service at 281.444.3946.



**Equi-Tax Inc.**  
*Ad Valorem Tax Assessors / Collectors*

www.equitaxinc.com 17111 Rolling Creek Drive, Suite 200, Houston, Texas 77090  
P. O. Box 73109, Houston, Texas 77273  
7/23/2020 Customer Service 281.444.3946 fax 281.440.8304

SYNDEX CORPORATION  
6950 NEUHAUS ST  
HOUSTON, TX 77061-4607

HOBBY AREA DISTRICT  
ACCOUNT NUMBER: R000201183 / 9[119602001000]  
LEGAL DESCRIPTION: RES A BLK 1 CENTRAL INDUSTRIAL PARK SEC 8  
SITUS: 6950 NEUHAUS ST  
YEAR: 2019 DATE PROCESSED: 7/23/2020

**NOTICE OF CHANGE IN TAX LIABILITY**

We have been notified by the Appraisal District of a change in the appraisal of your property that has resulted in a change in your tax liability for the 2019 tax year.

The explanation of the change is:

- Decrease in Appraised Value
- Exemption(s) Added
  - Homestead
  - Over 65
  - Disabled Person
  - Disabled Veteran
- Account Prorated
- Account Deleted
- Rendition Penalty Waived
- Other: \_\_\_\_\_
- Lawsuit Cause No.: 2019-63820

This action has resulted in a decrease in the amount you owe. Accordingly, we are issuing you a refund in the amount of \$2,700.00.

Note: Questions regarding the changes in value should be directed to the Appraisal District.

If you need more information, call Customer Service at 281.444.3946.

**Hobby Area District - Business Expense Report**

Both Sides		July		EXPENSES (SEE PAGE 4 OF FORM)										
DATE	ADDRESS & LOCATION NAME PURPOSE (Meeting, Seminar, Training, etc.) EMPLOYMENT THAT INCLUDES INDIVIDUAL & COMPANY NAMES AND SUPPORTING REASON FOR EXPENSE	ACCOUNT CODE	CONNECTION TRANSPORT	HOTEL CHARGES (EXCL. MEALS)	MEALS	PHONE	SUPPLIES	PARKING & TOLLS	OTHER	Amount Paid For	2019 Total (\$ 575)	TOTAL		
8/15/2020	Communication Absence	6173				\$100.00					\$0.00	\$100.00		
8/11/2020	Wage/Deliver calculator to IFO for school supply draw RT	6105								7.6	\$4.37	\$4.37		
8/15/2020	Wage/RED School Supply draw RT	6105								48.2	\$23.12	\$23.12		
											\$0.00	\$0.00		
											\$0.00	\$0.00		
											\$0.00	\$0.00		
											\$0.00	\$0.00		
											\$0.00	\$0.00		
											\$0.00	\$0.00		
											\$0.00	\$0.00		
											\$0.00	\$0.00		
SUBTOTAL				\$0.00	\$0.00	\$0.00	\$100.00	\$0.00	\$0.00	\$0.00	47.8	\$27.49		
TOTAL EXPENSES												\$127.49		
Less: Personal Expenses												\$0.00		
Less: Business Credits												\$0.00		
NET AMOUNT DUE EMPLOYEE												\$127.49		

Both Sides 08/17/20 JUL Approved By: [Signature] 8/17/20

0.575 IRS Mileage Reimbursement Rate

Balance Due: \$3,023.25

Invoice No: 304858  
Cust ID: 10331-13734-5948

Amount Enclosed: \$ \_\_\_\_\_

Bill To Information:  
Hobby Area Management District  
8121 Broadway St. #199  
HOUSTON, TX 77061

**Please Return To:**  
Mister Sweeper LP  
P. O. Box 560048  
Dallas, TX 75356-0048

Balance Due: \$785.35

Invoice No: 304859  
Cust ID: 10331-13734A-6391

Amount Enclosed: \$ \_\_\_\_\_

Bill To Information:  
Hobby Area Management District  
8121 Broadway St. #199  
HOUSTON, TX 77061

**Please Return To:**  
Mister Sweeper LP  
P. O. Box 560048  
Dallas, TX 75356-0048

PLEASE TEAR OFF TOP PORTION AND RETURN WITH PAYMENT.

Mister Sweeper LP  
P. O. Box 560048  
Dallas, TX 75356-0048  
(214) 688-4444 phone  
(214) 638-2833 fax

Invoice No: 304858  
Cust ID: 10331-13734-5948

\*\*\*\*\*  
\*\* INVOICE \*\*  
\*\*\*\*\*

Bill To:  
Hobby Area Management District  
8121 Broadway St. #199  
HOUSTON, TX 77061

Ship To:  
Hobby Area Mgmt. District  
Various Streets  
HOUSTON, TX 77001

Mister Sweeper LP  
P. O. Box 560048  
Dallas, TX 75356-0048  
(214) 688-4444 phone  
(214) 638-2833 fax

Invoice No: 304859  
Cust ID: 10331-13734A-6391

\*\*\*\*\*  
\*\* INVOICE \*\*  
\*\*\*\*\*

Bill To:  
Hobby Area Management District  
8121 Broadway St. #199  
HOUSTON, TX 77061

Ship To:  
Hobby Area Mgmt. District  
Various Streets  
HOUSTON, TX 77001

Date	P.O. No.	Terms	Due Date
8/11/2020		Net 30	9/10/2020
Hrs	Description	Unit Price	Amount
3.5	Telephone Rd from Dixie Rd to Alameda Genoa Rd	139.00	486.50
3.5	Broadway from Park Place Ave to Airport Blvd	139.00	486.50
3.5	Monroe from Gulf Frwy to Alameda Genoa Rd	139.00	486.50
3	Bellfort from Gulf Frwy to Mykawa	139.00	417.00
4.5	Alameda Genoa from Gulf Frwy to Mykawa	139.00	625.50
2.25	Airport Blvd from Gulf Frwy to Monroe and from Telephone Rd to Mykawa	139.00	312.75
1.5	Reveille from Dixie Rd to Telephone Rd	139.00	208.50

85603 Swept on August 04-05, 2020

Date	P.O. No.	Terms	Due Date
8/11/2020		Net 30	9/10/2020
Hrs	Description	Unit Price	Amount
4.5	I45 south bound feeder road from Kingsley St to Alameda Genoa Rd	139.00	625.50
1.15	Circle intersection @ I45 and Park Place Blvd and Broadway St (both side of the circle under I45)	139.00	159.85

85684 Swept on August 04, 2020

Subtotal \$3,023.25  
Sales Tax (8.25%) \$0.00  
Invoice Total \$3,023.25  
Payments/Credits \$0.00  
**Balance Due \$3,023.25**

Subtotal \$785.35  
Sales Tax (8.25%) \$0.00  
Invoice Total \$785.35  
Payments/Credits \$0.00  
**Balance Due \$785.35**

Invoice No: 304858  
Cust ID: 10331-13734-5948

Invoice No: 304859  
Cust ID: 10331-13734A-6391





8121 Broadway Interests LLC  
2429 Bissonnet  
Houston, TX 77005  
kellee@8121broadwayinterestsllc.com



# INVOICE

**BILL TO**  
Harris County Improvement  
District # 9  
Harris County Improvement  
District No. 9  
8121 Broadway Suite 135 and  
135S  
Houston, TX 77061

**INVOICE #** 1333  
**DATE** 08/18/2020  
**DUE DATE** 09/01/2020

**MONTH**  
SEPTEMBER

DATE	ACCOUNT SUMMARY	AMOUNT
07/14/2020	Balance Forward	2,450.00
	Other payments and credits after 07/14/2020 through 08/17/2020	-2,450.00
08/18/2020	Other invoices from this date	0.00
	New charges (details below)	2,450.00
	<b>Total Amount Due</b>	<b>2,450.00</b>

DATE	ACTIVITY	DESCRIPTION	QTY	RATE	AMOUNT
08/18/2020	Rental Fee	September 2020 - 135/135S	1	2,450.00	2,450.00

Please pay online or mail to the above address. **TOTAL OF NEW CHARGES** 2,450.00  
Payments received after the 5th will be charged a **BALANCE DUE** **\$2,450.00**  
15% late fee.

8121 Broadway Interests LLC  
2429 Bissonnet  
Houston, TX 77005  
kellee@8121broadwayinterestsllc.com



# INVOICE

**BILL TO**  
Harris County Improvement  
District # 9  
Harris County Improvement  
District No. 9  
8121 Broadway Suite 135 and  
135S  
Houston, TX 77061

**INVOICE #** 1341  
**DATE** 08/25/2020  
**DUE DATE** 09/24/2020

DATE	ACCOUNT SUMMARY	AMOUNT
08/18/2020	Balance Forward	2,450.00
	Other payments and credits after 08/18/2020 through 08/24/2020	0.00
08/25/2020	Other invoices from this date	0.00
	New charges (details below)	129.90
	<b>Total Amount Due</b>	<b>2,579.90</b>

DATE	ACTIVITY	DESCRIPTION	QTY	RATE	AMOUNT
05/20/2020	Services	Camera Footage Pull	1	129.90	129.90

Please pay online or mail to the above address. **TOTAL OF NEW CHARGES** 129.90  
Payments received after the 5th will be charged a **BALANCE DUE**  
15% late fee.



River Oaks Jeep

**Name and address, including county**  
BIBBY AREA DISTRICT  
8121 BROADWAY SUITE #139  
HOUSTON TX 77061

**Leasing address (if different)**  
N/A

**Principal driver (if business use)**  
N/A

**VEHICLE INFORMATION**  
RIVER OAKS JEEP  
2020 JEEP GRAND CHEROKEE  
1048J2AD41C145056  
HOUSTON TX 77098

**This is an agreement to lease a vehicle. This is not a purchase agreement. You are not buying the vehicle. By signing this lease, you agree to everything in this lease.**

**1. Amount Due at Lease Signing or Delivery (Netized Below)**  
\$ 7,500.00

**2(a). Monthly Scheduled Payments**  
Your first monthly payment of \$ 529.33 is due on 08/21/2020 followed by 35 payments of \$ 529.33 due on the 21st of each month. The total of your monthly payments is \$ 19,055.88.

**3. Other Charges not part of your scheduled payments**  
Total \$ 395.00

**4. Total of Payments**  
Total \$ 26,221.33

**5. Amount Due at Lease Signing or Delivery:**  
a. Capitalized cost reduction \$ 6,970.67  
b. Net trade-in allowance \$ N/A  
c. First monthly payment \$ 529.33  
d. Finance and noncash credits \$ 4350.00  
e. Single scheduled payment \$ N/A  
f. Residual value deposit \$ N/A  
g. Title fees \$ N/A  
h. Registration fees \$ N/A  
i. Sales tax \$ N/A  
j. N/A \$ N/A  
k. N/A \$ N/A  
Total \$ 1500.00

**6. How the Amount Due at Lease Signing or Delivery will be paid:**  
a. Net trade-in allowance \$ N/A  
b. Finance and noncash credits \$ 4350.00  
c. Amount to be paid in cash \$ 1000.00

**7. Your scheduled payment is determined as shown below:**  
a. Gross capitalized cost. The agreed upon value of the vehicle is \$ 35,218.00 and any items you pay for over the lease term (such as service contracts, insurance, and any outstanding prior credit or lease balance) \$ 3,850.40  
b. Capitalized cost reduction. The amount of any net trade-in allowance, rebate, noncash credit, or cash you pay that reduces the gross capitalized cost \$ 6,970.67  
c. Adjusted capitalized cost. The amount used in calculating your base scheduled payment \$ 31,537.33  
d. Residual value. The value of the vehicle at the end of the lease used in calculating your base scheduled payment \$ 1,948.50  
e. Depreciation and any amortized amounts. The amount charged for the vehicle's decline in value through normal use and for other items paid over the lease term \$ 1,209.23  
f. Rent charge. The amount charged in addition to the depreciation and any amortized amounts \$ 686.65  
g. Total of base scheduled payment(s). The depreciation and any amortized amounts plus the rent charge \$ 1,895.88  
h. Lease payments. The number of payments in your lease \$ 35  
i. Base scheduled payment \$ 529.33  
j. Schedule tax (estimated) \$ N/A  
k. N/A \$ N/A  
l. Total scheduled payment \$ 529.33

**8. Excessive Wear and Tear.** You may be charged for excessive wear based on your schedule for annual use and for mileage in excess of 12,000 miles per year at the rate of \$ 0.25 per mile.

**9. Purchase Option at End of Lease Term.** You have an option to buy the vehicle at the end of the lease term for \$ 19,564.50 plus other fees and taxes.

**10. Other Important Terms.** See your lease documents for additional information on early termination, purchase options and maintenance responsibilities, warranties, use and default charges, and insurance.

**11. Itemization of Gross Capitalized Cost.**

a. Agreed upon value of the vehicle	\$ 34,938.00
b. Ally administrative fee	\$ 695.00
c. License/registration/title fees	\$ 305.00
d. Sales tax	\$ 81.83
e. Other tax (estimated)	\$ N/A
f. Optional service contract	\$ 1,995.00
g. Optional maintenance contract	\$ N/A
h. Optional life insurance	\$ N/A
i. Optional disability insurance	\$ N/A
j. DOC FEE	\$ 459.33
k. EXOT FEE	\$ 150.00
l. N/A	\$ N/A
m. N/A	\$ N/A
n. Gross Capitalized Cost	\$ 38,564.40

**12. Optional Fees and Taxes.** You will pay all government license, title, registration, leasing, and inspection fees for the vehicle. You will pay all taxes on the lease, payments due under the lease, or the vehicle that the government levies on you, the vehicle, or its transport our not income taxes. We may charge your monthly payment if lease charges. We may bill you separately for critical fees and taxes.

**13. Disposition Fee Waiver.** We will waive any Disposition Fee shown in Section 5.f. if the lease term is 36 months, you enter into a motor vehicle lease or installment sale contract that the dealer assigns to Ally.

**14. Lease Term:** 36 months.

**15. Total Allowed Mileage.** The total mileage allowed on the odometer at lease end is 30,000 miles.

**16. Excess Miles.** The total allowed mileage includes N/A miles that you are buying at \$ N/A per mile. If this lease ends on or after the start of the next full monthly period, we will give you a credit for each unused mile you bought. There will be no credit if the lease ends earlier, you buy the vehicle, or the vehicle is a total loss.

**17. Optional Insurance, Service Contracts, and Maintenance Agreements.** We do not require any of the insurance, products, or services listed in this section. Your decision to buy them or not buy them is not a factor in our decision to approve this lease. We will try to get an optional insurance coverage that you retail below. A notice you receive when you sign this lease describes the coverage(s) in greater detail. Life insurance and disability insurance may not cover taxes and other amounts due before the lease monthly payment.

Optional Insurance	Coverage	Charge or Premium	Provide	By including codes, you indicate you want the insurance
Life Insurance (Monthly Payment Lease Only)	Lessee/Co-Lessee Coverage is for lease term	N/A	N/A	N/A
Disability Insurance (Monthly Payment Lease Only)	Lessee/Co-Lessee Coverage is for lease term	N/A	N/A	N/A
N/A	Monthly Coverage limit \$ N/A	N/A	N/A	N/A
N/A	Coverage limit \$ N/A	N/A	N/A	N/A

**Other Optional Product or Service**

Product/Service	Term	Charge
PLATINUM LEASE Pkg	N/A	None
N/A	N/A	None

SEE THE OTHER PAGES OF THIS LEASE FOR OTHER IMPORTANT AGREEMENTS INCLUDING A PROHIBITION OF TRANSFER OF YOUR INTEREST.



Name and address, including county HOBBY AREA DISTRICT 1121 BROADWAY, STE #199 HOUSTON TX 77061		Billing address (if different) N/A Physical driver (if business use) N/A		VEHICLE INFORMATION HELIPOINTE RIVER CARS CHRYSLER JEEP DODGE 4007 BROADWAY HOUSTON TX 77068	
--	--	---	--	--	--

This is an agreement to lease a vehicle. This is not a purchase agreement. You are not buying the vehicle. By signing this lease, you agree to everything on this form.

1. Monthly Payment Lease. If your payment schedule shows monthly scheduled payments (Section 20a), your lease is a monthly payment lease.  
2. Single Payment Lease. If your payment schedule shows a single scheduled payment (Section 20b), your lease is a single payment lease.

Year	Make & Model	Body Style	VIN	Mileage	Primary Use: Personal, unless otherwise indicated below
2022	JEEP GRAND CHUK	4DR SUV	1C4RJDAAG14C507	0	Personal, Business, or Agricultural

1. Amount Due at Lease Signing or Delivery (Estimated Below)	2(a). Monthly Scheduled Payments Your first monthly payment of \$ 529.33 is due on 08/21/2020 followed by 35 payments of \$ 529.33 due on the 21st of each month. The total of your monthly payments is \$ 19,555.85	3. Other Charges (not part of your scheduled payment) Disposition fee (if you do not purchase the vehicle and you do not waive the fee under Section 12) \$ 395.00	4. Total Payments (The amount you will have paid by the end of the lease)
\$ 7500.00	2(b). Single Scheduled Payment Your single payment of \$ N/A is due on N/A. This is the total of your scheduled payments.	Total \$ 395.00	\$ 24,431.35

5. Amount Due at Lease Signing or Delivery:		6. How the Amount Due at Lease Signing or Delivery will be paid:	
a. Capitalized cost reduction	\$ 879.67	a. Net trade-in allowance	\$ N/A
b. First monthly payment	\$ 529.33	b. Rebates and noncash credits	\$ 450.00
c. Single scheduled payment	\$ N/A	c. Amount to be paid in cash	\$ 3000.00
d. Refundable security deposit	\$ N/A		
e. Title fees	\$ N/A		
f. Registration fees	\$ N/A		
g. Sales tax	\$ N/A		
h. N/A	\$ N/A		
i. N/A	\$ N/A		
j. Total	\$ 7500.00		\$ 7500.00

7. Your scheduled payment is determined as shown below:

a. Gross capitalized cost. The agreed upon value of the vehicle is \$3500.00 and any items you pay for over the lease term (such as service contracts, insurance, and any outstanding prior credit or lease balances)	\$ 3850.40
b. Capitalized cost reduction. The amount of any net trade-in allowance, rebate, noncash credit, or cash you pay that reduces the gross capitalized cost	\$ 470.73
c. Adjusted capitalized cost. The amount used in calculating your base scheduled payment	\$ 3379.67
d. Residual value. The value of the vehicle at the end of the lease used in calculating your base scheduled payment	\$ 1946.56
e. Depreciation and any amortized amounts. The amount charged for the vehicle's decline in value through normal use and for other items paid over the lease term	\$ 12069.31
f. Rent charge. The amount charged in addition to the depreciation and any amortized amount	\$ 6286.55
g. Total of base scheduled payment(s). The depreciation and any amortized amount plus the rent charge	\$ 18355.88
h. Lease payments. The number of payments in your lease	36
i. Base scheduled payment	\$ 529.33
j. Sales tax (estimated)	\$ N/A
k. N/A	\$ N/A
l. Total scheduled payment	\$ 529.33

8. Excessive wear and tear. You may be charged for excessive wear based on our standards for normal use and for mileage in excess of 12,000 miles per year at the rate of \$ .25 per mile.

9. Purchase Option at End of Lease Term. You have an option to buy the vehicle at the end of the lease term for \$ 3956.50 plus optional fees and taxes.

10. Other Important Terms. See your lease documents for additional information on early termination, purchase options and maintenance responsibilities, warranties, late and default charges, and insurance.

SEE THE OTHER PAGES OF THIS LEASE FOR OTHER IMPORTANT AGREEMENTS INCLUDING A PROHIBITION OF TRANSFER OF YOUR INTEREST.

Lease Agreement to AF-071-MULTISTATE-0-1018 ALLY FINANCIAL  
CO. LA, MA, NE, OK, OR, TX, VT, WV, WY Page 1 of 3 Lessee's Initials: / Co-Lessee's Initials: N/A

11. Amortization of Gross Capitalized Cost.

a. Agreed upon value of the vehicle	\$ 3,500.00
b. Ally administrative fee	\$ 595.00
c. License/registration fees	\$ 205.00
d. Sales tax	\$ 54.83
e. Other tax (insurance)	\$ 0.00
f. Optional service contract	\$ 1,925.00
g. Optional maintenance contract	\$ N/A
h. Optional fleet insurance	\$ N/A
i. Optional disability insurance	\$ N/A
j. DOC FEE	\$ 150.00
k. TITAX	\$ 55.57
l. N/A	\$ 0.00
m. N/A	\$ 0.00
n. Gross Capitalized Cost	\$ 3,850.40

12. Official Fees and Taxes. You will pay all government license, title, registration, testing, and inspection fees for this vehicle. You will pay all taxes on the lease, payments due under the lease, or the vehicle that the government levies on you, the vehicle, or an (except our net income taxes). We may charge your monthly payment if taxes change. We may bill you separately for official fees and taxes.

13. Disposition Fee Waiver. We will waive any Disposition Fee shown at Section 7.1 of the lease this lease ends, you write into a motor vehicle lease or installment sale contract that the dealer assigns to Ally.

14. Lease Term: 36 months.

15. Total Allowed Mileage. The total mileage allowed on the odometer at lease end is 36,000 miles.

16. Extra Miles. The total allowed mileage includes N/A extra miles that you are buying at \$ .25 per mile. If the lease ends on or after the end of the month-end monthly period, we will give you a credit for each unused extra mile you bought. There will be no credit if the lease ends earlier, you buy the vehicle, or the vehicle is a total loss.

17. Optional Insurance, Service Contracts, and Maintenance Agreements. We do not require any of the insurance, products, or services listed in this section. Your decision to buy them or not buy them is not a factor in our decision to approve this lease. We will try to get any optional insurance coverage that you request below. A notice you receive when you sign this lease describes the coverage in greater detail. Life insurance and disability insurance may not cover lease and other amounts due besides the base monthly payment.

18. Required Vehicle Insurance Information. You affirm that liability and physical damage policies that meet our requirements (see Section 22) are in force on the date of this lease as follows:

Insurance company name:	
Insurance agency name:	
Agency address:	
Agency phone no.:	
Agency name:	
Holley no.:	
Documentation: Collision \$ 0.00 Comprehensive \$ 0.00	

17. WARRANTY AND EXCLUSION OF WARRANTY. You have the benefit of the standard manufacturer's warranty unless this box is checked.  If this box is checked, you have the benefit of the following warranty:

Warranty terms that are requested from this lease are any coverage limits in the lease. THERE ARE NO OTHER EXPRESS WARRANTIES ON THE VEHICLE.

The following exclusion and limitation of implied warranties does not apply if (i) you signed this lease in Massachusetts and you are an individual leasing for personal, family, or household use; (ii) you signed this lease in West Virginia and you are an individual leasing for a personal, family, household, or agricultural purpose unless Lessee makes a written warranty or enters into a service contract within 90 days from the date of this lease; LESSEE MAKES NO IMPLIED WARRANTY OF MERCHANTABILITY AND THERE IS NO IMPLIED WARRANTY OF MERCHANTABILITY OF THIS PARTICULAR VEHICLE. If Lessee makes a written warranty or enters into a service contract within 90 days from the date of this lease, then any implied warranty of merchantability and any warranty that the vehicle is fit for a particular purpose are limited in duration to the longer of the term of the written warranty or the term of the service contract.

Optional Insurance	Coverage	Charge or Premium	Provider	By indicating below, you indicate you want the insurance
Life Insurance (Monthly Payment Lease Only)	Lesser of Co Lease Coverage or for lease term Coverage limit \$ N/A	N/A	N/A	Lesser/Co Lease initial N/A / N/A
Disability Insurance (Monthly Payment Lease Only)	Coverage is for lease term Monthly Coverage limit \$ N/A	N/A	N/A	Lesser/Co Lease initial N/A / N/A
N/A	N/A	N/A	N/A	Lesser/Co Lease initial N/A / N/A

Other Optional Product or Service	Term	N/A	Months	N/A	Months
N/A					

Lease Agreement to AF-071-MULTISTATE-0-1018 ALLY FINANCIAL  
CO. LA, MA, NE, OK, OR, TX, VT, WV, WY Page 2 of 3 Lessee's Initials: / Co-Lessee's Initials: N/A

AmegyBank of Texas

CONTROL ACCOUNT  
HOBBY AREA DISTRICT  
Account Number: xxxxxxxx 0536

ACCOUNT SUMMARY

Account Number	xxxx xxxx 0536	Previous Balance	\$1,044.61
Credit Limit	\$10,000.00	Payments	\$1,044.61
Available Credit	\$5,903.00	Credits	\$0.00
Statement Closing Date	August 24, 2020	Purchases	\$4,096.50
Payment Due Date	September 13, 2020	Other Charges	\$0.00
Amount Past Due	\$0.00	Cash Advances	\$0.00
Min Payment Due	\$102.00	Finance Charges	\$0.00
Days in Billing Cycle	35	New Balance	\$4,096.50

REWARDS SUMMARY

BEGINNING REWARDS BALANCE	204.604	Log into internet banking www.amegybank.com to redeem your AmazZing Rewards points or call 1-855-662-9200.
1X CATEGORY EARNED THIS STATEMENT	3,719	
2X CATEGORY EARNED THIS STATEMENT	0	
3X CATEGORY EARNED THIS STATEMENT	1,133	
TOTAL REWARDS EARNED THIS STATEMENT	4,852	
REWARDS REDEEMED THIS STATEMENT	0	
ENDING REWARDS BALANCE	209.456	

TRANSACTIONS

Trans Date	Post Date	Reference Number	Transaction Description	Amount
08/11	08/11	7476800KHBKDRYONX	PAYMENT - THANK YOU	\$1,044.61
TOTAL XXXXXXXXXXXXX0536				\$1,044.61
WALTER FUNDS				
07/25	07/25	246921GZ2XAN7B77	MAILCHIMP *MISC MAILCHIMP COM GA	\$19.18
08/03	08/03	2420402K885NGKSG	TeamViewer.com 180-0514573 FL	\$635.04
08/20	08/20	246921GK12XDZLXZ	COMCAST OF HOUSTON 713-541-1000 TX	\$162.79

See Reverse Side for Important Information About Your Account.

5545 0801 BH 3 7 16 200826 0 PAGE 1 of 2 1.2 5396 0000 T8AR 01A45543 10759

AmegyBank of Texas

CONTROL ACCOUNT  
Account Number: xxxxxxxx 0556

TRANSACTIONS (Continued)

Trans Date	Post Date	Reference Number	Transaction Description	Amount
TOTAL XXXXXXXXXXXXX0504				\$817.01
BETH STROPE				
07/24	07/24	2451605JZFP0BAQW	SHELL OIL 37545457107 HOUSTON TX	\$26.00
07/24	07/24	244921531H14XSTQ	SP 1 THRADFELL OWS HTTPSTHREADFE WI	\$2,475.00
07/29	07/29	2490641K22WDFE1D	4IMPTRINT 877-4467746 WI	\$510.78
07/31	07/31	246921GK3QME7SE3	OOMA,INC 888-711-6662 CA	\$214.72
08/11	08/11	2443106KGLQG7V1HN7	ADDOB CREATIVE CLOUD 408-536-6000 CA	\$52.99
TOTAL XXXXXXXXXXXXX04084				\$3,279.49

Finance Charge Summary	Daily Periodic Rate (May Vary)	Total Finance Charge	Balance Subject to Finance Charge	Annual Percentage Rate
Purchase	0.03072%	\$0.00	\$0.00	11.25%
Cash Advances	0.04918%	\$0.00	\$0.00	18.00%

Questions: Remit To: Or Write:

Cardholder Services	1-866-749-7459	Bankcard Center	Bankcard Center
Lost or Stolen	1-866-749-7459	PO Box 30833	PO Box 25787
		Salt Lake City UT 84130	Salt Lake City UT 84125-0787

Visit us on the web at: www.amegybank.com  
Change of address? Please call 1-866-749-7459 or visit your local branch.

PAYMENT INFORMATION

Account Number	xxxx xxxx 0556
Payment Due Date	09/13/20
New Balance	\$4,096.50
Minimum Payment Due	\$102.00
Past Due Amount	\$0.00
Cash Enclosed	
Total Payment Amount	\$

5545 0801 BH 3 7 16 200826 0 PAGE 2 of 2 1.2 5396 0000 T8AR 01A45543 10759



**HOBBY AREA DISTRICT**

Mr. Danny R. Perkins  
ESC Polytech Consultants, Inc.  
8800 Paul B. Koonce Street  
Houston, TX 77061

Client/Matter: HOB000-01  
Statement Number: 113740  
Billing Attorney: Timothy Austin

**Hobby Area District - Business Expense Report**

DATE	DESCRIPTION	ACCOUNT	AMOUNT	PAID	UNPAID	TOTAL
08/07/20	Phone conversation with director regarding upcoming executive committee meeting; attend special executive committee meeting	8000	\$0.00	\$0.00	\$0.00	\$0.00
08/07/20	Executive committee meeting regarding personnel; call to chairman regarding same.	8000	\$0.00	\$0.00	\$0.00	\$0.00
08/11/20	Research and forward document as requested.	8000	\$0.00	\$0.00	\$0.00	\$0.00
08/11/20	Call to Chairman regarding personnel.	8000	\$0.00	\$0.00	\$0.00	\$0.00
08/12/20	Phone conversation with staff and research regarding police officer liability	8000	\$0.00	\$0.00	\$0.00	\$0.00
08/12/20	Research and forward documents as requested.	8000	\$0.00	\$0.00	\$0.00	\$0.00
08/13/20	Attend board meeting; research and discussion regarding police officer liability; discuss upcoming board meeting; prepare draft audit response letter and cover letter; review and update director contact information; review district correspondence; discuss draft service agreement	8000	\$0.00	\$0.00	\$0.00	\$0.00
08/13/20	Prepare for and attend District meeting.	8000	\$0.00	\$0.00	\$0.00	\$0.00
08/14/20	Review district correspondence; discuss director appointments and related filings; follow up regarding director contact information; review proposal and related correspondence regarding graphic design services; prepare and discuss draft service agreement	8000	\$0.00	\$0.00	\$0.00	\$0.00
08/18/20	Review draft complaint and prepare same for submission to governmental agency; phone conversation with director regarding pending matters and follow up discussion regarding same	8000	\$0.00	\$0.00	\$0.00	\$0.00
08/20/20	Review district correspondence; review Chapter 49, Water Code, and discuss authority regarding document execution	8000	\$0.00	\$0.00	\$0.00	\$0.00
08/20/20	Research regarding District requirements for execution of documents	8000	\$0.00	\$0.00	\$0.00	\$0.00
08/21/20	Phone conversation with staff regarding pending matters; conference call regarding agenda procedures	8000	\$0.00	\$0.00	\$0.00	\$0.00
08/21/20	Conference call to discuss agenda procedures.	8000	\$0.00	\$0.00	\$0.00	\$0.00
	<b>Total Fees:</b>					<b>8,247.50</b>
	<b>Total Expenses and Other Items:</b>					<b>0.00</b>
	<b>Total Amount Due:</b>					<b>\$ 8,247.50</b>

**General**

**Professional Fees**

Fees for services posted through August 21, 2020, as follows:

Date	Professional	Hours	
07/27/20	Carnell Emanuel	Review district correspondence; review and discuss purchasing policy; phone conversation with staff regarding personnel matters	1.00
07/27/20	Timothy Austin	Conference with Carnell Emanuel regarding agreement terms.	0.50
08/03/20	Timothy Austin	Calls to Chairman and to Susan Hill regarding personnel issues.	0.75
08/04/20	Carnell Emanuel	Review procedures relating to Texas Commission on Environmental Quality Advanced Compliance History Review and update tracking chart for same; prepare correspondence regarding special executive committee meeting; phone conversation with chairman and consultant regarding personnel matters and scheduling of special executive committee meeting	1.50
08/05/20	Carnell Emanuel	Review procedures relating to videoconferencing; follow up with board of directors regarding scheduling of special executive session; review and discuss procedures relating to Texas Commission on Environmental Quality Advanced Compliance History; review and update tracking chart for same; prepare letter to Texas Commission on Environmental Quality regarding Advanced Compliance History Review; phone conversation and follow up with directors regarding scheduling of special executive session	2.00
08/06/20	Carnell Emanuel	Discuss upcoming executive committee meeting; submit and discuss videoconference request form	0.50
08/06/20	Timothy Austin	Conference with Carnell Emanuel and call to Beth Slope regarding employment issue.	1.00

Allen Boone Humphries Robinson LLP

September 03, 2020

**Hobby Area District  
HOB000-01**

Statement Number: 113740

Page: 2

DATE	PROFESSIONAL	DESCRIPTION	HOURS
08/07/20	Carnell Emanuel	Phone conversation with director regarding upcoming executive committee meeting; attend special executive committee meeting	1.50
08/07/20	Timothy Austin	Executive committee meeting regarding personnel; call to chairman regarding same.	1.75
08/11/20	Kelsie Wade	Research and forward document as requested.	0.25
08/11/20	Timothy Austin	Call to Chairman regarding personnel.	0.50
08/12/20	Carnell Emanuel	Phone conversation with staff and research regarding police officer liability	0.50
08/12/20	Kelsie Wade	Research and forward documents as requested.	0.25
08/13/20	Carnell Emanuel	Attend board meeting; research and discussion regarding police officer liability; discuss upcoming board meeting; prepare draft audit response letter and cover letter; review and update director contact information; review district correspondence; discuss draft service agreement	5.00
08/13/20	Timothy Austin	Prepare for and attend District meeting.	1.50
08/14/20	Carnell Emanuel	Review district correspondence; discuss director appointments and related filings; follow up regarding director contact information; review proposal and related correspondence regarding graphic design services; prepare and discuss draft service agreement	2.00
08/18/20	Carnell Emanuel	Review draft complaint and prepare same for submission to governmental agency; phone conversation with director regarding pending matters and follow up discussion regarding same	1.75
08/20/20	Carnell Emanuel	Review district correspondence; review Chapter 49, Water Code, and discuss authority regarding document execution	1.00
08/20/20	Susan Hostetter	Research regarding District requirements for execution of documents	0.25
08/21/20	Carnell Emanuel	Phone conversation with staff regarding pending matters; conference call regarding agenda procedures	0.75
08/21/20	Timothy Austin	Conference call to discuss agenda procedures.	0.50

**Total Fees: 8,247.50**

**Total Fees: \$ 8,247.50**

**Total Expenses and Other Items: \$ 0.00**

**Total Amount Due: \$ 8,247.50**

**Arthur Perez**

Security and Networking Consulting  
4714 Silver Spruce Lane  
Friendswood, Texas 77546  
832-309-6937

**INVOICE**

INVOICE NO: 200905  
DATE: September 5, 2020

Bill To:  
Hobby Area District  
8121 Broadway, Suite 199  
Houston, TX 77061

CUSTOMER	P.O. NUMBER	SERVICE DATE	PROJECT	ONSITE SERVICE	TERMS
HADIST	Verbal	08-2020	004	Yes	NET 30

QUANTITY	DESCRIPTION	UNIT PRICE	AMOUNT
1.00	08/21/2020 File sharing setup of OneDrive files	175.00	175.00
1.50	08/28/2020 Restore last laptop config including bilocker setup	175.00	262.50

SUBTOTAL	\$437.50
BALANCE FORWARD	00
<b>TOTAL DUE</b>	<b>\$437.50</b>

SPECIAL NOTE:  
Please make check payable to Arthur Perez at above address

If you have any questions concerning this invoice, call me at 832-309-6937

**THANK YOU FOR YOUR BUSINESS!**





# INVOICE

Busy Bee Creatives LLC  
 P.O. Box 1993  
 Spring, TX 77263-1993  
 United States  
 281.658.0741  
 BusyBeeCreatives.com

# CLARK CONDON

10401 STELLA LINK ROAD  
 HOUSTON, TEXAS 77025  
 phone 713.871.1414 fax 713.871.0888  
 CLARKCONDON.COM

**BILL TO**  
 Hobby Area Management District  
 Beth Strobe  
 P.O. Box 22167  
 Houston, Texas 77227  
 United States  
 832.982.2026  
 BStrobe@hadistrict.org

Invoice Number: 639  
 Invoice Date: September 2, 2020  
 Payment Due: September 16, 2020  
 Amount Due (USD): \$3,000.00

Beth Strobe  
 Hobby Area Management District  
 8121 Broadway, Suite 199  
 Houston, TX 77061

Date: August 31, 2020  
 Invoice number: 46847  
 Project Number: 120-090

**Hobby Area Gateway Preliminary Design**

Professional Services for the Period: 8/1/2020 to 8/31/2020

Items	Quantity	Price	Amount
<b>Website Maintenance + Social Media</b>	1	\$3,000.00	\$3,000.00
<ul style="list-style-type: none"> <li>• Hosting of the site</li> <li>• Regular security scans and malware protection</li> <li>• Daily back-up of database, weekly back-up of complete website</li> <li>• Restore of website from back-up if needed</li> <li>• Update of WordPress core system as needed</li> <li>• Update of plug-ins as needed</li> <li>• Posting of news and board materials</li> <li>• Maintenance of email database</li> <li>• Monthly e-news letter</li> <li>• Mass email campaigns as needed</li> <li>• Brand management of social media accounts</li> <li>• Posting and scheduling news and campaigns on social media</li> </ul>			
<b>Total:</b>			\$3,000.00
<b>Amount Due (USD):</b>			<b>\$3,000.00</b>

Phase	Phase Fee	% Complete	Fee Earned	Prior Billing	Current Fee
Preliminary Design	\$35,000.00	75.07	\$26,275.00	\$10,500.00	\$15,775.00
	\$35,000.00	75.07	\$26,275.00	\$10,500.00	\$15,775.00

**Reimbursables**

PHASE SUMMARY:	
Phase Maximum	\$3,000.00
Previous Billings	\$95.68
Current Billing	\$146.05
Balance After This Invoice	\$2,758.27

In-House Printing	\$127.00
Expense Fee	\$19.05
<b>Total Reimbursables</b>	<b>\$146.05</b>

**TOTAL AMOUNT DUE \$15,921.05**

https://accounting.waveapps.com/invoices/4779168/export/1015151451309164109/5268583977535667747650454F31325969586C54565787456575... 1/2

**Activity Summary Report**

Date Range: 07/31/2020 to 08/30/2020

Project / Media / Page Size / Cost	Qty	Total Units / Sq Ft	Total Cost
<b>120-090 - Hobby Area Gateway Preliminary Design</b>			
Color Laser —cost each			
11.00x17.00			
Unit Cost: \$3.00	41.00	82.00	\$123.00
8.50x11.00			
Unit Cost: \$2.00	2.00	2.00	\$4.00
<b>Total for 120-090 - Hobby Area Gateway Preliminary Design</b>	<b>43.00</b>		<b>\$127.00</b>

Ledger: September 2020

Hobby Area Management District  
 P.O. Box 22167  
 Houston, TX 77027

Make check payable to:  
 Core Logic Sales Rent  
 P.O. Box 402893  
 Atlanta, GA 30388-9493

Invoice Date	Parent #	Acct #	Hobby Area Apartments	Management Company	RAA	Units	RCR Sub Fee	
8/1/2020	T6412	T3376	2065 Shelburn	Byrnes Group Investments	Yes	23	\$5.75	
8/1/2020	T6412	T6407	Alta Verde	First Choice Management	Yes	1420	\$357.50	
8/1/2020	T6412	T5423	Bellevue Villas	New Capital Partners	Yes	62	\$15.86	
8/1/2020	T6412	T1322	Bellfort East	Captain Investment Corp	Yes	58	\$14.50	
8/1/2020	T6412	T3294	Bellfort Plaza	Andy Hernandez	Yes	154	\$38.50	
8/1/2020	T6412	T8864	Broadway Casa	Gonetto	Yes	150	\$37.50	
8/1/2020	T6412	T3499	Broadway Village	Gonetto	Yes	220	\$55.00	
8/1/2020	T6412	T6454	Cabo San Lucas	Nova Property Management	Yes	1060	\$266.50	
8/1/2020	T6412	T6482	Casa Anita	Naraki Management	Yes	24	\$6.00	
8/1/2020	T6412	T6463	Casa Chur	Superior Plus Real Estate Group	Yes	262	\$65.50	
8/1/2020	T6412	T5451	Casa Grande	Excelsior Investment	Yes	69	\$15.75	
8/1/2020	T6412	T5778	Chesmont City	Tadik Management	Yes	328	\$82.00	
8/1/2020	T6412	T3868	Del Lago	CWR Interests	Yes	162	\$40.50	
8/1/2020	T6412	T2804	Glover Place Rpts.	TADRock Asset Management	Yes	32	\$8.00	
8/1/2020	T6412	T6450	Esperanza	ORR Property Management LLC	Yes	29	\$7.25	
8/1/2020	T6412	T6452	Grabancreek Manor	Forbes & Sharer Properties	Yes	50	\$12.50	
8/1/2020	T6412	T1320	Leander	Captain Investment Corp	Yes	41	\$10.25	
8/1/2020	T6412	T6400	Leonora	Infantium Property Management	No	62	\$15.50	
8/1/2020	T6412	T3259	Leonora Square	Infantium Property Management	No	38	\$9.50	
8/1/2020	T6412	T6480	Los Arcos	T&M Enterprises	Yes	66	\$16.50	
8/1/2020	T6412	T6290	Marley Street Apts.	Palm Villanvestments	Yes	4	\$1.50	
8/1/2020	T6412	T1403	Pebble Walk	Gonetto	Yes	228	\$57.00	
8/1/2020	T6412	T6681	Pecan Villa Apts.	Pecan Villa Apts, LLC	Yes	20	\$5.00	
8/1/2020	T6412	T4966	Redford Square	Condasa Property Group	Yes	61	\$15.25	
8/1/2020	T6412	T6458	Sharing Court Adj Homes	Greiner Coastal Management Co	Yes	340	\$85.00	
8/1/2020	T6412	T2811	The Life at Clearwood	The Life Property Management	Yes	276	\$69.00	
8/1/2020	T6412	T6459	The Reserve at Bellfort	Lampson Capital Mgmt.	Yes	204	\$51.00	
8/1/2020	T6412	T6672	The Savannah Apts	BBW Broadway LLC	Yes	306	\$76.50	
8/1/2020	T6412	T6693	Tropicana Apts	Creative Property Management	Yes	40	\$10.00	
8/1/2020	T6412	T6483	Vista Verde	First Choice Management	Yes	1040	\$260.00	
REMIT THIS STATEMENT WITH PAYMENT							6626	\$1,697.25



East End District  
 P.O. Box 230099  
 Houston, TX 77223 US  
 713-928-9916  
 eva@eastenddistrict.com

**INVOICE**

**BILL TO**  
 Danny Perkins  
 Hobby Area Management  
 District  
 8121 Broadway, Ste. 199  
 Houston, Texas 77061

**INVOICE #** 23-78  
**DATE** 08/31/2020  
**DUE DATE** 09/30/2020  
**TERMS** Net 30

DATE	ACTIVITY	QTY	RATE	AMOUNT
08/03/2020	<b>Graffiti Abatement</b> Constituent visits, waiver collection, follow-up visits, graffiti identification, reporting, and graffiti abatement. Sites Abated: 7	8	85.00	680.00
08/10/2020	<b>Graffiti Abatement</b> Constituent visits, waiver collection, follow-up visits, graffiti identification, reporting, and graffiti abatement. Sites Abated: 10	8	85.00	680.00
08/17/2020	<b>Graffiti Abatement</b> Constituent visits, waiver collection, follow-up visits, graffiti identification, reporting, and graffiti abatement. Sites Abated: 8	8	85.00	680.00
08/24/2020	<b>Graffiti Abatement</b> Constituent visits, waiver collection, follow-up visits, graffiti identification, reporting, and graffiti abatement. Sites Abated: 24	8	85.00	680.00
08/31/2020	<b>Graffiti Abatement</b> Constituent visits, waiver collection, follow-up visits, graffiti identification, reporting, and graffiti abatement. Sites Abated: 10	8	85.00	680.00

Total Sites Abated: 59 **BALANCE DUE \$3,400.00**

**Equi-Tax Inc.**

Suite 200  
 17111 Rolling Creek Drive  
 Houston Texas 77090  
 281-444-4866

<b>BILL TO</b>
Hobby Area District c/o Bracewell LLP Suite 2300 711 Louisiana Street Houston TX 77002-2770

**Invoice**

DATE	INVOICE #
9/1/2020	55868

DESCRIPTION	AMOUNT
Monthly Assessor Services fee per Contract	2,568.84
Roll Management	300.00
<b>Total</b>	<b>\$2,868.84</b>



East End District  
 P.O. Box 230099  
 Houston, TX 77223 US  
 713-928-9916  
 eva@eastenddistrict.com

**INVOICE**

**BILL TO**  
 Danny Perkins  
 Hobby Area Management  
 District  
 8121 Broadway, Ste. 199  
 Houston, Texas 77061

**INVOICE #** 28-41  
**DATE** 08/31/2020  
**DUE DATE** 09/30/2020  
**TERMS** Net 30

DATE	ACTIVITY	QTY	RATE	AMOUNT
08/07/2020	<b>Field Services</b> Inspections, surveying, and follow-ups	4	35.00	140.00
08/07/2020	<b>Reporting - Field Services</b> Reporting and follow-up.	2	35.00	70.00
08/07/2020	<b>Mileage Reimbursement</b> 73.0 Miles	73	0.575	41.98
08/14/2020	<b>Field Services</b> Inspections, surveying, and follow-ups	4	35.00	140.00
08/14/2020	<b>Reporting - Field Services</b> Reporting and follow-up.	1	35.00	35.00
08/14/2020	<b>Mileage Reimbursement</b> 70.6 Miles	70.60	0.575	40.60
08/20/2020	<b>Field Services</b> Inspections, surveying, and follow-ups	4	35.00	140.00
08/20/2020	<b>Reporting - Field Services</b> Reporting and follow-up.	2	35.00	70.00
08/20/2020	<b>Mileage Reimbursement</b> 73.3 Miles	73.30	0.575	42.15
08/28/2020	<b>Field Services</b> Inspections, surveying, and follow-ups	4	35.00	140.00
08/28/2020	<b>Reporting - Field Services</b> Reporting and follow-up.	2	35.00	70.00
08/28/2020	<b>Mileage Reimbursement</b> 73.1 Miles	73.10	0.575	42.03

**BALANCE DUE \$971.76**

Ev1pro  
 6315 Gessner Rd, Suite A  
 Houston, TX 77041 US  
 ev1pro@ev1pro.com  
 ev1pro.com



**INVOICE**

**BILL TO**  
 Gabrielle Dirden  
 Hobby Area Management  
 District  
 8121 Broadway suite 199  
 Houston, Tx 77061

**INVOICE #** 1966  
**DATE** 09/02/2020  
**DUE DATE** 09/02/2020  
**TERMS** Due on receipt

DESCRIPTION	QTY	RATE	AMOUNT
HAD Scholarship photo coverage on Jun,22,2020	1	300.00	300.00
HAD Calculators donation on Aug,11,2020	1	200.00	200.00
HAD School drive photo coverage on Aug,15,2020	1	300.00	300.00

**BALANCE DUE \$800.00**

**Governmental  
Financial  
Reporting, LLC**

1525 Lakeville Drive, Suite 121  
Kingwood, TX 77339  
(281) 348-9151  
FAX (281) 348-9199

9/7/2020

Hobby Area District  
8121 Broadway Blvd, Ste 199  
Houston, TX 77061

For Professional Services Rendered

Bookkeeping services provided during August 2020 for the month of July 2020	1,000.00
Postage and Deliveries	60.43
Mileage - Virtual Board Meeting	0.00

\$1,060.43



**Remittance Section**

Invoice Number: 27717431  
Agreement Number: 013-1245091-000  
Invoice Print Date: 08/31/2020  
Due Date: 09/24/2020  
Current Charges: \$383.25  
Past Due Amount: \$348.42  
Total Due: \$731.68

FORWARDING SERVICE REQUESTED

Check here for change of address (see reverse for details)

Use enclosed envelope and make check payable to:

MDG2015 00055475 1 AB 0.41  
ATTN: ACCOUNTS PAYABLE  
HOBBY AREA DISTRICT  
8121 BROADWAY ST # 199  
HOUSTON TX 77061-1340

GreatAmerica Financial Svcs.  
PO Box 660831  
Dallas, TX 75266-0831



00001312450910000000000277174310000000000731688

Keep lower portion for your records - Please return upper portion with your payment



Invoice Number: 27717431  
Due Date: 09/24/2020  
Total Due: \$731.68

**Important Messages**

Your payment is past due. Please remit the total due.

If you wish to complete a check-by-phone payment, please call the customer support number on this invoice. This option is provided to you for a nominal fee.

**Invoice Detail**

Agreement 013-1245091-000: Konica Minolta C458 with PC-415 Paper Feed Cabinet	Amount	Tax	Total
1 Late Charges For 08/28/2020	34.84	0.00	34.84
2 Standard Payment	348.42	0.00	348.42
<b>Subtotal of Current Charges</b>			<b>\$383.25</b>
<b>Summary of Past Due Charges</b>			
Invoice 2752971 - Due 09/24/2020			348.42
<b>Subtotal of Past Due Charges</b>			<b>\$348.42</b>

For more information about your invoice, please:  
- Call us at 866-339-9781  
- Email us at [customersupport-01@accountservicing.com](mailto:customersupport-01@accountservicing.com)  
- Visit [www.AccountServicing.com](http://www.AccountServicing.com)  
- (Para Español, pida la extensión 2544.)

**Total Due** ~~\$731.68~~

Debitored Checks, Drafts Or Orders Shall Be Subject To A Surcharge Of 5%

**Invoice**



Invoice #: 43016420  
Date: 9/3/2020

P. O. Box 22187  
Houston TX 77227-2187

Bill To:  
Hobby Area Management District (HCID #9)  
8121 Broadway, Suite 199  
Houston, TX 77061

Description	Amount
Professional consulting and administration/management support services, August 2020	\$9,000.00
GIS/mapping, P. Horton, August 2020	\$68.74
Agenda posting, Harris County Clerk, 8/7/2020	\$9.36
Reimbursable mileage, parking, tolls, related expenses: L. Clayton, August 2020	\$23.00

HOBBY AREA MGMT. DISTRICT  
HAWES HILL & ASSOCIATES LLP  
PATRICK HORTON (GIS-MAPPING)

EXPENSE DETAIL (HOBBY)		PAPER + INK					
DATE	CLIENT	DESCRIPTION	LABOR	COPIES	RESRCE. COST	SIZE (SF)	ITEM TOTAL
8/21/2020	B. Slope	Create simple map of Reveille Park for Food and	0.0833	0	0.00		\$0.00
		Mask Distribution Event (PDF)					
8/26/2020	B. Slope	Edit map of Reveille Park for Food and Mask Dist.	0.3333	0	0.00		\$0.00
		Event to include arrows and labelling per City					
8/28/2020	Misc.	Update HCAD Real Property Records	0.0417	0	0.00		\$0.00
<b>TOTAL</b>			<b>0.46</b>	<b>0</b>			<b>\$0.00</b>
Rate: \$150/hr			\$69.74				

I certify that the above is true and correct to the best of my knowledge.

Patrick L. Horton  
Date: 9/3/2020

Your Order #	Total Amount:	\$9,101.10
	Amount Applied:	\$0.00
	Balance Due:	\$9,101.10



Chris Hollins, County Clerk  
Personal Records (713) 274-8686  
201 Caroline, STE 330, Houston, TX 77002  
Fee Officer's Official Receipt



HOBBY AREA DISTRICT

TO: THE BOARD OF DIRECTORS OF THE HOBBY AREA DISTRICT AND TO ALL OTHER INTERESTED PERSONS:

NOTICE is hereby given that a regular meeting of the Board of Directors of the Hobby Area District will be held on Thursday, August 13, 2020, at 1:00 p.m., via Zoom videoconference at: <https://us02web.zoom.us/j/85089201191?pwd=CTdwanlKd3V0ZGhwa1Nybz9PSGhtZz09> - or via teleconference at: 1-346-248-7799 US (Houston), Meeting ID: 850 8920 1191, Passcode: 492379, open to the public, to consider, discuss, and make recommendations, and take direct actions as may be necessary, desirable, or convenient with respect to the following matters:

AGENDA

1. Call to order; determine quorum.
2. Public comments.
3. Approve Minutes of Board Meeting held June 11, 2020.
4. Receive Bookkeeper's Report and approve payment of invoices.
5. Receive Assessments Collection and Delinquency Report.
6. Approve FY2019 Annual Financial Report and Audit from McCall Gibson Swedlund Barfoot, PLLC.
7. Receive presentation from Clark Condon, LLC, regarding Hobby Area Preliminary Gateway Designs.
8. Consider proposal from Tribe Design for graphic design services for District newsletter; and authorize execution of agreement.
9. Consider proposal from UpArt Studio for refreshing painted surfaces of District's mini-murals; and authorize execution of agreement.
10. Approve Letter Agreements necessary to set up off-duty police officer services.
11. Approve recognition of Lt. Irving.
12. Appoint Budget Committee and Nominating Committee.
13. Discuss strategies for monitoring activities with potential impact on the District during the legislative session which convenes in January 2021.
14. Executive Session - Convene Executive Session pursuant to Section 551.074, Texas Government Code, to deliberate the appointment, employment, evaluation, reassignment, duties, discipline, or dismissal of a public officer or employee.
15. Reconvene in Open Session - Reconvene in Open Session and authorize appropriate action regarding the appointment, employment, evaluation, reassignment, duties, discipline, or dismissal of a public officer or employee.
16. Executive Director's Report/Board Member or Staff Announcements.
17. Next Meeting - October 8, 2020.
18. Adjourn

*Beth Strope*  
Executive Director



\*As a result of the current COVID-19 virus epidemic emergency, the convening at one location of a quorum of the Board is difficult or impossible. Therefore, the Board will conduct this meeting by teleconference call rather than by physical quorum pursuant to Texas Government Code Sec. 551.125 and guidance of the Governor of the State of Texas. Members of the public are entitled to participate and address the Board during the telephonic meeting. In all respects, this meeting will be open to the public and compliant with applicable law and guidance of the Governor of the State of Texas. An electronic copy of the agenda packet (which consists of the regular reports presented to the Board by its consultants) can be found at <https://hoadistrict.org/>

HOBBY AREA DISTRICT

Receipt #: PR20019131  
Receipt Date: 08/07/2020 04:03:02 PM  
Fees Assessed By: CCO/mhoughton  
Cashier: Salas, Ada (CCD)

Fee Description	Amount	Notes
Credit Card Surcharge	\$0.36	NOTICE OF PUBLIC MEETING - 1411111
County Clerk	\$9.00	HOBBY AREA DISTRICT; TO THE PUBLIC
<b>Total:</b>	<b>\$9.36</b>	<b>\$9.36</b>

Tender Type	Tender SubType	Check # / CC Auth #	Tender Amount
CREDIT CARD	Visa	Surcharge: \$0.36	\$9.36
<b>Total Paid:</b>			<b>\$9.36</b>

THANK YOU

Print Date : 08/07/2020 04:03:02 PM

Customer Copy

HOUSTON BUSINESS JOURNAL

Dear David,  
You have been selected for this exclusive test rate subscription to Houston Business Journal due to your dedication to your local business community.



Try a risk-free, annual subscription at this special preferred rate. We are so certain you'll enjoy it, that we'll refund all unserved issues (no questions asked), if you don't.

**A Special Rate - plus a hard copy of the upcoming Book of Lists!**

Standard Price	Credit Adjustment	Special Price
\$140.00	- \$65.00	\$75.00

Item	Description	Total
001	<b>Weekly Print Edition</b> - filled with "must read" stories, industry news recaps and reporter insights, exclusive interviews, plus expanded Top 25 Lists with full contact information.	Only \$1.44 per week
002	<b>Morning &amp; Afternoon Editions</b> - Houston's business news headlines conveniently delivered to your inbox each day.	Included
003	<b>iPad App and Digital Edition Archive</b> - research hundreds of back issues and get even more business leads from our exclusive subscriber-only online tools.	Included
004	<b>People on the Move</b> - search the database, download leads, and expand your network.	Included
005	<b>Special Bonus</b> - upcoming Houston Book of Lists (worth \$80).	Included

**Money-Back Guarantee:** If you are ever dissatisfied, you'll get a FULL REFUND on all unserved issues. No questions asked!

Call us toll free: 1-866-853-3661 or Visit us online: [bizjournals.com/greatoffer](http://bizjournals.com/greatoffer)

† If paying by check, detach here and return bottom portion in the provided prepaid envelope †

Date	Description	Business Manager	Project	Mark Drawn	Sheet	Amount	TS/NO
5 Aug	8121 Broadway	District Office to pick up Reminders		40		\$	9
				40		\$	
I certify that the above information was reviewed and used by me: <i>Shade Clayton</i> 8/14/2020				Signature (TS) _____ Date (NO) _____		Amount Billed to District \$ 23.89 Total Remittance \$ 23.89	

HOUSTON BUSINESS JOURNAL

5444 Westheimer,  
Ste 1500  
Houston, TX 77056

RETURN WITHIN: 5 BUSINESS DAYS

\*\*\*\*\*AUTO\*\*SCH 6-DIGIT 77027  
424892 DA 21 044 3 00185066  
DAVID HAWES  
HOBBY AREA MANAGEMENT DISTRICT  
PO BOX 22167  
HOUSTON TX 77227-2167

AMOUNT DUE

\$81.19

Includes applicable sales tax.

Provide the email address and phone number you will use to access this subscription:

\*Email: \_\_\_\_\_

\_\_\_\_\_-\_\_\_\_\_-\_\_\_\_\_-

H00707253645

**McCALL GIBSON SWEDLUND BARFOOT PLLC**  
 Certified Public Accountants

13100 Wortham Center Circle  
 Suite 235  
 Houston, Texas 77065-5610  
 (713) 482-0441  
 Fax (713) 482-2708  
 E-Mail: [mgsw@mgswpllc.com](mailto:mgsw@mgswpllc.com)

9600 Great Hills Trail  
 Suite 1500V  
 Austin, Texas 78759  
 (512) 616-2209  
[www.mgspllc.com](http://www.mgspllc.com)

September 18, 2020

Hobby Area District  
 c/o Governmental Financial Reporting, LLC  
 1525 Lakeview Drive, Suite 121  
 Kingwood, TX 77339

Client Number: 350-05

Audit of Hobby Area District as of December 31, 2019, and for the year then ended including discussion of the Audit and Supplemental Information with the Board of Directors and testing the District's compliance with the Public Funds Investment Act.	
Annual Audit Fee	\$ 16,000.00
Less Interim Billing	10,000.00
<b>Balance Due</b>	<b>\$ 6,000.00</b>

*We appreciate having you as a client.  
 Thank you for your business.  
 Joseph Ellis*

Member of  
 American Institute of Certified Public Accountants  
 Texas Society of Certified Public Accountants

Balance Due: \$3,023.25

Invoice No: 305036  
 Cust ID: 10331-13734-5948

Amount Enclosed: \$ \_\_\_\_\_

Bill To Information:  
 Hobby Area Management District  
 8121 Broadway St. #199  
 HOUSTON, TX 77061

Please Return To:  
 Mister Sweeper LP  
 P. O. Box 560048  
 Dallas, TX 75356-0048

PLEASE TEAR OFF TOP PORTION AND RETURN WITH PAYMENT.

Mister Sweeper LP  
 P. O. Box 560048  
 Dallas, TX 75356-0048  
 (214) 688-4444 phone  
 (214) 638-2833 fax

Invoice No: 305036  
 Cust ID: 10331-13734-5948

\*\*\*\*\*  
**\*\* INVOICE \*\***  
 \*\*\*\*\*

Bill To:  
 Hobby Area Management District  
 8121 Broadway St. #199  
 HOUSTON, TX 77061

Ship To:  
 Hobby Area Mgmt. District  
 Various Streets  
 HOUSTON, TX 77001

Date	P.O. No.	Terms	Due Date
8/27/2020		Net 30	9/26/2020
Hrs	Description	Unit Price	Amount
3.5	Telephone Rd from Dixie Rd to Almeda Genoa Rd	139.00	486.50
3.5	Broadway from Park Place Ave to Airport Blvd	139.00	486.50
3.5	Monroe from Gulf Frwy to Almeda Genoa Rd	139.00	486.50
3	Bellfort from Gulf Frwy to Mykawa	139.00	417.00
4.5	Almeda Genoa from Gulf Frwy to Mykawa	139.00	625.50
2.25	Airport Blvd from Gulf Frwy to Monroe and from Telephone Rd to Mykawa	139.00	312.75
1.5	Reveille from Dixie Rd to Telephone Rd	139.00	208.50

85604 Swept on August 17-18, 2020

Subtotal \$3,023.25  
 Sales Tax (8.25%) \$0.00  
 Invoice Total \$3,023.25  
 Payments/Credits \$0.00

**Balance Due \$3,023.25**

Invoice No: 305036  
 Cust ID: 10331-13734-5948

Balance Due: \$785.35

Invoice No: 305037  
 Cust ID: 10331-13734A-6391

Amount Enclosed: \$ \_\_\_\_\_

Bill To Information:  
 Hobby Area Management District  
 8121 Broadway St. #199  
 HOUSTON, TX 77061

Please Return To:  
 Mister Sweeper LP  
 P. O. Box 560048  
 Dallas, TX 75356-0048

PLEASE TEAR OFF TOP PORTION AND RETURN WITH PAYMENT.

Mister Sweeper LP  
 P. O. Box 560048  
 Dallas, TX 75356-0048  
 (214) 688-4444 phone  
 (214) 638-2833 fax

Invoice No: 305037  
 Cust ID: 10331-13734A-6391

\*\*\*\*\*  
**\*\* INVOICE \*\***  
 \*\*\*\*\*

Bill To:  
 Hobby Area Management District  
 8121 Broadway St. #199  
 HOUSTON, TX 77061

Ship To:  
 Hobby Area Mgmt. District  
 Various Streets  
 HOUSTON, TX 77001

Date	P.O. No.	Terms	Due Date
8/27/2020		Net 30	9/26/2020
Hrs	Description	Unit Price	Amount
4.5	145 south bound feeder road from Kingsley St to Almeda Genoa Rd	139.00	625.50
1.15	Circle intersection @ 145 and Park Place Blvd and Broadway St (both side of the circle under 145)	139.00	159.85

85685 Swept on August 19, 2020.

Subtotal \$785.35  
 Sales Tax (8.25%) \$0.00  
 Invoice Total \$785.35  
 Payments/Credits \$0.00

**Balance Due \$785.35**

Invoice No: 305037  
 Cust ID: 10331-13734A-6391



**Invoice**

Invoice Number: 30681  
 Invoice Date: Aug 31, 2020

Sold To:  
 Hobby Area Management District  
 ATTN: Accounts Payable  
 8121 Broadway, Suite 199  
 Houston, TX 77061  
 832-982-2026

Job Location:  
 HAMD/ Damaged Banner Signs  
 Broadway Blvd @ District Offices  
 Houston, TX

Customer ID	Customer Contact	Customer P. O.	Job Number	NEC Salesman	Payment Terms
HOBBYAREA DISTRICT	Beth Strape		A21512	Anthony Richards	Due Upon Receipt
Quantity	Description	Unit Price	Total Price		
	Furnished labor and material to remove damaged banner signs. Brought to shop for repair, and reinstallation.				
2.00	Banner signage removal:	410.00	820.00		
2.00	Repair and reinstallation:	1,820.00	3,640.00		

Thank you for your business

Subtotal \$4,460.00  
 Sales Tax  
 Total Invoice Amount \$4,460.00  
 Payment Received  
**TOTAL \$4,460.00**

PLEASE REMIT PAYMENT TO:  
 NEON ELECTRIC CORPORATION  
 NEC SIGNAGE + ARCHITECTURAL PRODUCTS  
 1122 LAUDER ROAD  
 HOUSTON, TX 77039-2902

PHONE: (281) 987-1144  
 FAX: (281) 987-9443  
[necsigns.net](http://necsigns.net)



PERDUE, BRANDON, FIELDER, COLLINS & MOTT LLP  
Attorneys at Law  
1235 North Loop West, Suite 600  
Houston, Texas 77008

INVOICE	IVC00053895
Type	
Date	8/3/2020
Page	1



**SEAL Security Solutions LLC**

1525 Blalock Road  
Houston, TX 77080-7318  
www.SEALSecurity.com  
713-979-2388  
TX DPS Lic. #C15942

**Invoice**

Date	Invoice #
8/17/2020	48887

**Bill to:**

Harris County ID #9 (Hobby Area Management Dis  
c/o Equi-Tax, Inc.  
PO Box 73109  
Houston, TX 77273

**Bill To**

Hobby Management District  
8121 Broadway, Suite 199  
Houston, TX 77061

Description	Ext. Price
Professional Services rendered in the collection of delinquent taxes, penalties and interest 06/26/2020-07/29/2020	\$2,104.90
<b>Total</b>	<b>\$2,104.90</b>

Description	Hours	Rate/ Hour	Terms
			Net 30
Commissioned Security Officer with Vehicle and K-9 Patrol Period 08/10/2020 through 08/16/2020  Patrols are billed every Monday for the hours patrolled the week preceding the above invoice date.  This invoice is Monday through Sunday inclusive.	198.5	31.00	6,153.50
NOTE: A 2% convenience fee will be charged on all payments made by credit card.			Sales Tax (8.25%) \$0.00
<b>Thank you for allowing us to earn your business.</b>		<b>Total</b>	<b>\$6,153.50</b>



**SEAL Security Solutions LLC**

1525 Blalock Road  
Houston, TX 77080-7318  
www.SEALSecurity.com  
713-979-2388  
TX DPS Lic. #C15942

**Invoice**

Date	Invoice #
8/24/2020	48976



**SEAL Security Solutions LLC**

1525 Blalock Road  
Houston, TX 77080-7318  
www.SEALSecurity.com  
713-979-2388  
TX DPS Lic. #C15942

**Invoice**

Date	Invoice #
8/31/2020	49058

**Bill To**

Hobby Management District  
8121 Broadway, Suite 199  
Houston, TX 77061

**Bill To**

Hobby Management District  
8121 Broadway, Suite 199  
Houston, TX 77061

Description	Hours	Rate/ Hour	Terms
			Net 30
Commissioned Security Officer with Vehicle and K-9 Patrol Period 08/17/2020 through 08/23/2020  Patrols are billed every Monday for the hours patrolled the week preceding the above invoice date.  This invoice is Monday through Sunday inclusive.	190.5	31.00	5,905.50
NOTE: A 2% convenience fee will be charged on all payments made by credit card.			Sales Tax (8.25%) \$0.00
<b>Thank you for allowing us to earn your business.</b>		<b>Total</b>	<b>\$5,905.50</b>

Description	Hours	Rate/ Hour	Terms
			Net 30
Commissioned Security Officer with Vehicle and K-9 Patrol Period 08/24/2020 through 08/30/2020  Patrols are billed every Monday for the hours patrolled the week preceding the above invoice date.  This invoice is Monday through Sunday inclusive.	197.75	31.00	6,130.25
NOTE: A 2% convenience fee will be charged on all payments made by credit card.			Sales Tax (8.25%) \$0.00
<b>Thank you for allowing us to earn your business.</b>		<b>Total</b>	<b>\$6,130.25</b>



# SEAL Security Solutions LLC

1525 Blalock Road  
Houston, TX 77080-7318  
www.SEALSecurity.com  
713-979-2388  
TX DPS Lic. #C15942

# Invoice

Date	Invoice #
9/7/2020	49204

SMC Landscape Services  
13107 James Ln.  
Stafford, TX 77477 US  
hello@smclandscape.com  
www.smclandscape.com



# INVOICE

**BILL TO**  
Beth Stropo  
Hobby Area Management  
District  
8121 Broadway Suite 199  
Houston, TX 77061

**SHIP TO**  
Beth Stropo  
Hobby Area Management  
District  
8121 Broadway Suite 199  
Houston, TX 77061

**INVOICE #** 2749  
**DATE** 09/08/2020  
**DUE DATE** 10/08/2020  
**TERMS** Net 30

Bill To
Hobby Management District 8121 Broadway, Suite 199 Houston, TX 77061

Description	Hours	Rate/ Hour	Terms	
			Net 30	Amount
Commissioned Security Officer with Vehicle and K-9	196	31.00		6,076.00
Patrol Period 08/31/2020 through 09/06/2020				
Patrols are billed every Monday for the hours patrolled the week preceding the above invoice date.				
This invoice is Monday through Sunday inclusive.				
NOTE: A 3% convenience fee will be charged on all payments made by credit card.			Sales Tax (8.25%)	\$0.00
<b>Thank you for allowing us to earn your business.</b>		<b>Total</b>		<b>\$6,076.00</b>

ACTIVITY	QTY	RATE	AMOUNT
Hobby Broadway Landscape Maintenance 2020	1	11,984.12	11,984.12
August Broadway Landscape Maintenance			
Hobby Special Projects 2020	1	14,302.28	14,302.28
August Litter abatement of right-of-way for Hobby Area Management District			
Hobby Gulf Freeway Landscape Maintenance 2020	1	7,442.69	7,442.69
August Gulf Freeway Landscape Maintenance			
Hobby Metro Bus Shelter Maintenance 2020	1	785.64	785.64
August METRO Bus Shelter Maintenance			
Special Project	1	375.00	375.00
Vermin Control Bait Refill August 2020			
We appreciate your prompt payment.			<b>BALANCE DUE \$34,889.73</b>

SMC Landscape Services  
13107 James Ln.  
Stafford, TX 77477 US  
hello@smclandscape.com  
www.smclandscape.com



# INVOICE

**BILL TO**  
Beth Stropo  
Hobby Area Management  
District  
8121 Broadway Suite 199  
Houston, TX 77061

**SHIP TO**  
Beth Stropo  
Hobby Area Management  
District  
8121 Broadway Suite 199  
Houston, TX 77061

**INVOICE #** 2767  
**DATE** 09/16/2020  
**DUE DATE** 10/16/2020  
**TERMS** Net 30

ACTIVITY	QTY	RATE	AMOUNT
Irrigation Services	1	45.00	45.00
8070 Broadway- lateral line broken			
Irrigation Services	2	75.00	150.00
8115 Broadway- drip line broken			
Irrigation Services	1	75.00	75.00
8221 Broadway- drip line broken			
Irrigation Services	1	45.00	45.00
8403 Broadway- lateral line broken			
Irrigation Services	8	75.00	600.00
Labor			

Repairs completed on August 3, 2020

**BALANCE DUE \$915.00**

Texas Excavation Safety System, Inc.  
PO Box 678058  
(972) 231-5497  
Dallas TX 75267



# Invoice #20-16414

8/31/2020

## AMOUNT DUE

**Bill To**  
Hobby Area District  
Attn: Walter Funes  
8121 Broadway St, Suite 199  
Houston TX 77061  
United States

**\$337.25**  
Due Date: 9/30/2020

Terms	Due Date	PO #	Additional Info	Status
Net 30	9/30/2020			Open

Quantity	Description	Rate	Amount
361	Message Fees for August 2020 / HOD	\$0.95	\$342.95
6	Credit for cancelled notifications / HOD	\$-0.95	\$-5.70
<b>Total</b>			<b>\$337.25</b>
<b>Amount Paid</b>			<b>\$0.00</b>
<b>Amount Due</b>			<b>\$337.25</b>



20-16414



**Zaladium Analytics LLC**

1525 Blalock Road  
Houston, TX 77080  
832-900-9969  
www.zaladium.com  
TX PSB# C20262

**Invoice**

Date	Invoice #
8/26/2020	48865

Bill To	Camera Location								
Hobby Management District 8121 Broadway, Suite 199 Houston, TX 77061									
	<table border="1"> <thead> <tr> <th>Terms</th> </tr> </thead> <tbody> <tr> <td>Net 30</td> </tr> </tbody> </table>	Terms	Net 30						
Terms									
Net 30									
Description	Amount								
One 2 PTZ cameras plug-in pole unit -Includes off-hours monitoring and response -Pole # ZEE061 Location: Double Tree 8181 Airport Blvd, Houston, TX 77061	850.00								
One 2 PTZ cameras plug-in pole unit -Includes off-hours monitoring and response -Pole # ZEE063 Location: 7987 Belfort, Houston, TX 77061	850.00								
Monitoring Period from 08/26/2020 through 09/25/2020 Monitoring invoices are billed every month for the entire month. This invoice is billed in advance for the month.									
	<table border="1"> <tbody> <tr> <td><b>Sales Tax (8.25%)</b></td> <td>50.00</td> </tr> <tr> <td><b>Total</b></td> <td>\$1,700.00</td> </tr> <tr> <td><b>Payments/Credits</b></td> <td>50.00</td> </tr> <tr> <td><b>Balance Due</b></td> <td>\$1,700.00</td> </tr> </tbody> </table>	<b>Sales Tax (8.25%)</b>	50.00	<b>Total</b>	\$1,700.00	<b>Payments/Credits</b>	50.00	<b>Balance Due</b>	\$1,700.00
<b>Sales Tax (8.25%)</b>	50.00								
<b>Total</b>	\$1,700.00								
<b>Payments/Credits</b>	50.00								
<b>Balance Due</b>	\$1,700.00								

**Equi-Tax Inc.**  
*Ad Valorem Tax Assessors / Collectors*

www.equitaxinc.com

17111 Rolling Creek Drive, Suite 200, Houston, Texas 77090

8/25/2020

P. O. Box 73109, Houston, Texas 77273  
Customer Service 281.444.3946 fax 281.440.8304

Astro, Hobby, West Mt Renal Care  
Limited Partnership as Lessee  
c/o Popp Hutcheson PLLC  
1301 S MoPac Expressway Ste 430  
Austin, TX 78746

HOBBY AREA DISTRICT  
ACCOUNT NUMBER: R000201208 / 911227220010001  
LEGAL DESCRIPTION: RES A BLK 1 DA VITA HOBBY  
SITUS: 8560 MONROE RD  
YEAR: 2019

DATE PROCESSED: 8/25/2020

**NOTICE OF CHANGE IN TAX LIABILITY**

We have been notified by the Appraisal District of a change in the appraisal of your property that has resulted in a change in your tax liability for the 2019 tax year.

The explanation of the change is Lawsuit Cause No.: 2019-64486

This action has resulted in a decrease in the amount you owe. Accordingly, we are issuing you a refund in the amount of \$1,477.05.

Note: Questions regarding the changes in value should be directed to the Appraisal District.

If you need more information, call Customer Service at 281.444.3946.

**Paid by Check # 3084****Equi-Tax Inc.**  
*Ad Valorem Tax Assessors / Collectors*

www.equitaxinc.com

17111 Rolling Creek Drive, Suite 200, Houston, Texas 77090

8/25/2020

P. O. Box 73109, Houston, Texas 77273  
Customer Service 281.444.3946 fax 281.440.8304**VERDE COMMUNITIES LLC**

c/o Popp Hutcheson PLLC  
1301 S MoPac Expressway Ste 430  
Austin, TX 78746

**HOBBY AREA DISTRICT**

ACCOUNT NUMBER: R000200106 / 910402390000100  
LEGAL DESCRIPTION: TRS 39 & 39A ABST 27 J R HARRIS  
SITUS: 8501 BROADWAY ST 380  
YEAR: 2019

DATE PROCESSED: 8/25/2020

**NOTICE OF CHANGE IN TAX LIABILITY**

We have been notified by the Appraisal District of a change in the appraisal of your property that has resulted in a change in your tax liability for the 2019 tax year.

The explanation of the change is Lawsuit Cause No.: 2019-49259

This action has resulted in a decrease in the amount you owe. Accordingly, we are issuing you a refund in the amount of \$2,221.25.

Note: Questions regarding the changes in value should be directed to the Appraisal District.

If you need more information, call Customer Service at 281.444.3946.

**Paid by Check # 3085****Equi-Tax Inc.**  
*Ad Valorem Tax Assessors / Collectors*

www.equitaxinc.com

17111 Rolling Creek Drive, Suite 200, Houston, Texas 77090

8/25/2020

P. O. Box 73109, Houston, Texas 77273  
Customer Service 281.444.3946 fax 281.440.8304**VERDE COMMUNITIES LLC**

c/o Popp Hutcheson PLLC  
1301 S MoPac Expressway Ste 430  
Austin, TX 78746

**HOBBY AREA DISTRICT**

ACCOUNT NUMBER: R000200109 / 910402390000108  
LEGAL DESCRIPTION: TR 40B ABST 27 J R HARRIS  
SITUS: 8750 BROADWAY ST 222  
YEAR: 2019

DATE PROCESSED: 8/25/2020

**NOTICE OF CHANGE IN TAX LIABILITY**

We have been notified by the Appraisal District of a change in the appraisal of your property that has resulted in a change in your tax liability for the 2019 tax year.

The explanation of the change is Lawsuit Cause No.: 2019-49259

This action has resulted in a decrease in the amount you owe. Accordingly, we are issuing you a refund in the amount of \$1,478.63.

Note: Questions regarding the changes in value should be directed to the Appraisal District.

If you need more information, call Customer Service at 281.444.3946.

**Paid by Check # 3085**





**Equi-Tax Inc.**  
Ad Valorem Tax Assessors / Collectors

www.equitaxinc.com

17111 Rolling Creek Drive, Suite 200, Houston, Texas 77090  
P.O. Box 73109, Houston, Texas 77273  
Customer Service 281.444.3946 fax 281.440.8304

8/25/2020

VERDE COMMUNITIES LLC  
c/o Popp Hutcheson PLLC  
1301 S MoPac Expressway Ste 430  
Austin, TX 78746

HOBBY AREA DISTRICT  
ACCOUNT NUMBER: R000201138 / 911097860000001  
LEGAL DESCRIPTION: RES A BROADWAY SQUARE BUSINESS PARK  
SITUS: 8751 BROADWAY ST 213  
YEAR: 2019 DATE PROCESSED: 8/25/2020

**NOTICE OF CHANGE IN TAX LIABILITY**

We have been notified by the Appraisal District of a change in the appraisal of your property that has resulted in a change in your tax liability for the 2019 tax year.

The explanation of the change is Lawsuit Cause No.: 2019-49259

This action has resulted in a decrease in the amount you owe. Accordingly, we are issuing you a refund in the amount of \$1,439.93.

Note: Questions regarding the changes in value should be directed to the Appraisal District.

If you need more information, call Customer Service at 281.444.3946.

**Paid by Check # 3085**



**Equi-Tax Inc.**  
Ad Valorem Tax Assessors / Collectors

www.equitaxinc.com

17111 Rolling Creek Drive, Suite 200, Houston, Texas 77090  
P.O. Box 73109, Houston, Texas 77273  
Customer Service 281.444.3946 fax 281.440.8304

8/25/2020

VERDE COMMUNITIES LLC  
c/o Popp Hutcheson PLLC  
1301 S MoPac Expressway Ste 430  
Austin, TX 78746

HOBBY AREA DISTRICT  
ACCOUNT NUMBER: R000200107 / 910402390000101  
LEGAL DESCRIPTION: TR 38 ABST 27 J R HARRIS  
SITUS: 8751 BROADWAY ST 224  
YEAR: 2019 DATE PROCESSED: 8/25/2020

**NOTICE OF CHANGE IN TAX LIABILITY**

We have been notified by the Appraisal District of a change in the appraisal of your property that has resulted in a change in your tax liability for the 2019 tax year.

The explanation of the change is Lawsuit Cause No.: 2019-49259

This action has resulted in a decrease in the amount you owe. Accordingly, we are issuing you a refund in the amount of \$1,478.64.

Note: Questions regarding the changes in value should be directed to the Appraisal District.

If you need more information, call Customer Service at 281.444.3946.

**Paid by Check # 3085**



**Equi-Tax Inc.**  
Ad Valorem Tax Assessors / Collectors

www.equitaxinc.com

17111 Rolling Creek Drive, Suite 200, Houston, Texas 77090  
P.O. Box 73109, Houston, Texas 77273  
Customer Service 281.444.3946 fax 281.440.8304

8/25/2020

VERDE COMMUNITIES LLC  
c/o Popp Hutcheson PLLC  
1301 S MoPac Expressway Ste 430  
Austin, TX 78746

HOBBY AREA DISTRICT  
ACCOUNT NUMBER: R000201147 / 911141750000001  
LEGAL DESCRIPTION: RES E I & F BROADWAY SQUARE PH K  
SITUS: 8955 BROADWAY ST 208  
YEAR: 2019 DATE PROCESSED: 8/25/2020

**NOTICE OF CHANGE IN TAX LIABILITY**

We have been notified by the Appraisal District of a change in the appraisal of your property that has resulted in a change in your tax liability for the 2019 tax year.

The explanation of the change is Lawsuit Cause No.: 2019-49259

This action has resulted in a decrease in the amount you owe. Accordingly, we are issuing you a refund in the amount of \$1,358.01.

Note: Questions regarding the changes in value should be directed to the Appraisal District.

If you need more information, call Customer Service at 281.444.3946.

**Paid by Check # 3085**



**Equi-Tax Inc.**  
Ad Valorem Tax Assessors / Collectors

www.equitaxinc.com

17111 Rolling Creek Drive, Suite 200, Houston, Texas 77090  
P.O. Box 73109, Houston, Texas 77273  
Customer Service 281.444.3946 fax 281.440.8304

8/25/2020

VERDE COMMUNITIES LLC  
c/o Popp Hutcheson PLLC  
1301 S MoPac Expressway Ste 430  
Austin, TX 78746

HOBBY AREA DISTRICT  
ACCOUNT NUMBER: R000201140 / 911097860000003  
LEGAL DESCRIPTION: RES C & D1 BROADWAY SQUARE BUSINESS PARK  
SITUS: 8801 GLENCREST ST 322  
YEAR: 2019 DATE PROCESSED: 8/25/2020

**NOTICE OF CHANGE IN TAX LIABILITY**

We have been notified by the Appraisal District of a change in the appraisal of your property that has resulted in a change in your tax liability for the 2019 tax year.

The explanation of the change is Lawsuit Cause No.: 2019-49259

This action has resulted in a decrease in the amount you owe. Accordingly, we are issuing you a refund in the amount of \$1,916.66.

Note: Questions regarding the changes in value should be directed to the Appraisal District.

If you need more information, call Customer Service at 281.444.3946.

**Paid by Check # 3085**



**Equi-Tax Inc.**  
Ad Valorem Tax Assessors / Collectors

www.equitaxinc.com 17111 Rolling Creek Drive, Suite 200, Houston, Texas 77090  
P. O. Box 73109, Houston, Texas 77273  
8/25/2020 Customer Service 281.444.3946 fax 281.440.8304

VERDE COMMUNITIES LLC  
c/o Popp Hutcheson PLLC  
1301 S MoPac Expressway Ste 430  
Austin, TX 78746

HOBBY AREA DISTRICT  
ACCOUNT NUMBER: R000201142 / 911097870000007  
LEGAL DESCRIPTION: RES G & H1 BROADWAY SQUARE BUSINESS PARK  
SITUS: 8900 GLENCREST ST 208  
YEAR: 2019 DATE PROCESSED: 8/25/2020

**NOTICE OF CHANGE IN TAX LIABILITY**

We have been notified by the Appraisal District of a change in the appraisal of your property that has resulted in a change in you tax liability for the 2019 tax year.

The explanation of the change is Lawsuit Cause No.: 2019-49259

This action has resulted in a decrease in the amount you owe. Accordingly, we are issuing you a refund in the amount of \$1,470.03.

Note: Questions regarding the changes in value should be directed to the Appraisal District.

If you need more information, call Customer Service at 281.444.3946.

**Paid by Check # 3085**



**Equi-Tax Inc.**  
Ad Valorem Tax Assessors / Collectors

www.equitaxinc.com 17111 Rolling Creek Drive, Suite 200, Houston, Texas 77090  
P. O. Box 73109, Houston, Texas 77273  
8/25/2020 Customer Service 281.444.3946 fax 281.440.8304

VERDE COMMUNITIES LLC  
c/o Popp Hutcheson PLLC  
1301 S MoPac Expressway Ste 430  
Austin, TX 78746

HOBBY AREA DISTRICT  
ACCOUNT NUMBER: R000201146 / 911141690000001  
LEGAL DESCRIPTION: RES E BROADWAY SQUARE PH J  
SITUS: 8950 GLENCREST ST 200  
YEAR: 2019 DATE PROCESSED: 8/25/2020

**NOTICE OF CHANGE IN TAX LIABILITY**

We have been notified by the Appraisal District of a change in the appraisal of your property that has resulted in a change in you tax liability for the 2019 tax year.

The explanation of the change is Lawsuit Cause No.: 2019-49259

This action has resulted in a decrease in the amount you owe. Accordingly, we are issuing you a refund in the amount of \$1,395.17.

Note: Questions regarding the changes in value should be directed to the Appraisal District.

If you need more information, call Customer Service at 281.444.3946.

**Paid by Check # 3085**



**Equi-Tax Inc.**  
Ad Valorem Tax Assessors / Collectors

www.equitaxinc.com 17111 Rolling Creek Drive, Suite 200, Houston, Texas 77090  
P. O. Box 73109, Houston, Texas 77273  
8/25/2020 Customer Service 281.444.3946 fax 281.440.8304

VERDE COMMUNITIES LLC  
c/o Popp Hutcheson PLLC  
1301 S MoPac Expressway Ste 430  
Austin, TX 78746

HOBBY AREA DISTRICT  
ACCOUNT NUMBER: R000201143 / 911097870000008  
LEGAL DESCRIPTION: RES H BROADWAY SQUARE BUSINESS PARK  
SITUS: 8950 GLENCREST ST 200  
YEAR: 2019 DATE PROCESSED: 8/25/2020

**NOTICE OF CHANGE IN TAX LIABILITY**

We have been notified by the Appraisal District of a change in the appraisal of your property that has resulted in a change in you tax liability for the 2019 tax year.

The explanation of the change is Lawsuit Cause No.: 2019-49259

This action has resulted in a decrease in the amount you owe. Accordingly, we are issuing you a refund in the amount of \$1,452.68.

Note: Questions regarding the changes in value should be directed to the Appraisal District.

If you need more information, call Customer Service at 281.444.3946.

**Paid by Check # 3085**



**Equi-Tax Inc.**  
Ad Valorem Tax Assessors / Collectors

www.equitaxinc.com 17111 Rolling Creek Drive, Suite 200, Houston, Texas 77090  
P. O. Box 73109, Houston, Texas 77273  
8/25/2020 Customer Service 281.444.3946 fax 281.440.8304

VERDE COMMUNITIES LLC  
c/o Popp Hutcheson PLLC  
1301 S MoPac Expressway Ste 430  
Austin, TX 78746

HOBBY AREA DISTRICT  
ACCOUNT NUMBER: R000201139 / 911097860000002  
LEGAL DESCRIPTION: RES B BROADWAY SQUARE BUSINESS PARK  
SITUS: 7900 MORLEY ST 292  
YEAR: 2019 DATE PROCESSED: 8/25/2020

**NOTICE OF CHANGE IN TAX LIABILITY**

We have been notified by the Appraisal District of a change in the appraisal of your property that has resulted in a change in you tax liability for the 2019 tax year.

The explanation of the change is Lawsuit Cause No.: 2019-49259

This action has resulted in a decrease in the amount you owe. Accordingly, we are issuing you a refund in the amount of \$1,779.76.

Note: Questions regarding the changes in value should be directed to the Appraisal District.

If you need more information, call Customer Service at 281.444.3946.

**Paid by Check # 3085**





CONTROL ACCOUNT  
HOBBY AREA DISTRICT  
Account Number :  
XXXX XXXX XXXX 0536



ACCOUNT SUMMARY

Account Number	XXXX XXXX XXXX 0536	Previous Balance	\$4,096.50
Credit Limit	\$10,000.00	Payments	\$4,096.50
Available Credit	\$9,961.00	Credits	\$655.04
Statement Closing Date	September 22, 2020	Purchases	\$675.80
Payment Due Date	October 12, 2020	Other Charges	\$0.00
Amount Past Due	\$0.00	Cash Advances	\$0.00
Min Payment Due	\$50.00	Finance Charges	\$0.00
Days in Billing Cycle	29	New Balance	\$538.76

REWARDS SUMMARY

BEGINNING REWARDS BALANCE	209,456	Log into internet banking www.amegybank.com to redeem your AmEZing Rewards points or call 1-855-662-9200.
1X CATEGORY EARNED THIS STATEMENT	337	
2X CATEGORY EARNED THIS STATEMENT	0	
3X CATEGORY EARNED THIS STATEMENT	1,012	
TOTAL REWARDS EARNED THIS STATEMENT	1,349	
REWARDS REDEEMED THIS STATEMENT	0	
ENDING REWARDS BALANCE	210,805	

Paid by Check # 3086

TRANSACTIONS

Trans Date	Post Date	Reference Number	Transaction Description	Amount
09/09	09/09	7476800LEBKDRZ195	PAYMENT - THANK YOU	-\$4,096.50
TOTAL XXXXXXXXXXXXXXX0536				\$4,096.50

08/25	08/25	2469216KYSSHK1LG3	MAILCHIMP *MISC MAILCHIMP.COM GA	\$38.55
TOTAL XXXXXXXXXXXXXXX0536				\$38.55

See Reverse Side for Important Information About Your Account.

5045 0001 84H 3 7 16 200922 0 PAGE 1 of 2 12 5390 0000 TRAR 01A05043 4254



P O BOX 30855  
SALT LAKE CITY UT 84130-0855

For prompt credit, mail payment to location shown below.  
Deposits made on days without location may delay crediting your account.  
Please detach this portion and return it with your payment to ensure proper credit.

Make Checks Payable to :

BANKCARD CENTER  
PO BOX 30855  
SALT LAKE CITY UT 84130-0855

PAYMENT INFORMATION

Account Number	XXXX XXXX XXXX 0536
Payment Due Date	10/12/20
New Balance	\$538.76
Minimum Payment Due	\$50.00
Past Due Amount	\$0.00
Cash Enclosed	
Total Payment Amount	\$

CONTROL ACCOUNT  
HOBBY AREA DISTRICT  
8121 BROADWAY ST STE 199  
HOUSTON TX 77061-1340

4254  
REP

⑆5066 0000⑆53980000 20 20536⑆

CONTROL ACCOUNT  
Account Number :  
XXXX XXXX XXXX 0536

TRANSACTIONS (Continued)

Trans Date	Post Date	Reference Number	Transaction Description	Amount
BETH STROPE				
08/31	08/31	2469216L42XGGA7FB	OOMA,INC 888-711-6662 CA	\$174.37
09/11	09/11	2443105FLQJ54Z20	ADOBE CREATIVE CLOUD 408-536-6000 CA	\$52.99
09/15	09/15	2401339LK0202HA2M	CENTRAL TEXAS BRQ HOUSTON TX	\$52.99
09/15	09/15	2423168LLR8GHFTFR	FAMILY DOLLAR #7920 HOUSTON TX	\$10.83
09/17	09/17	2444500LMBFM70Z2H1	99 CENTS ONLY STORES#2830 HOUSTON TX	\$34.74
09/18	09/18	2401399LN02DCZEAT	CENTRAL TEXAS BRQ HOUSTON TX	\$100.00
09/18	09/18	2415746LP0103R8S3	CVS/PHARMACY #05657 HOUSTON TX	\$4.54
09/18	09/18	2423900LNS66JKVA0	ASHLEY'S DONUTS HOUSTON TX	\$62.19
09/20	09/20	2469216LR2XV0T934	COMCAST OF HOUSTON 713-541-1000 TX	\$162.80
TOTAL XXXXXXXXXXXXXXX04084				\$625.45
09/11	09/11	F539800LF000AC255	FRAUD ADJUSTMENT	-\$635.04
TOTAL XXXXXXXXXXXXXXX0514				\$635.04

Finance Charge Summary	Daily Periodic Rate (May Vary)	Total Finance Charge	Balance Subject to Finance Charge	Annual Percentage Rate
Purchase	0.05072%	\$0.00	\$0.00	11.25%
Cash Advances	0.04918%	\$0.00	\$0.00	18.00%

Questions	Remit To:	Or Write:
Cardholder Services 1-866-749-7459 Lost or Stolen 1-866-749-7459	Bankcard Center PO Box 30855 Salt Lake City UT 84130	Bankcard Center PO Box 25787 Salt Lake City UT 84125-0787

Visit us on the web at: www.amegybank.com  
Change of address? Please call 1-866-749-7459 or visit your local branch.

Hobby Area District - Business Expense Report

DATE	ADDRESS & LOCATION (NAME, PURPOSE (Meeting, Supplies, Training, etc.) & EMPLOYER THAT INCURRED INDIVIDUAL & COMPANY NAMES AND SUPPORTING REASON FOR EXPENSE)	ACCOUNT CODE	COMMERCIAL TRANSPORT	HOTEL CHARGES (EXCL. MEALS)	MEALS	PHONE	SUPPLIES	FURNISH & TOLLS	OTHER	Personal Auto Use (Total @ 5¢)	2018 Total @ 5¢	TOTAL											
8/31/2020	OOMA, INC	8173							\$174.37	\$0.00	\$0.00	\$174.37											
9/11/2020	ADOBE	8173							\$52.99	\$0.00	\$0.00	\$52.99											
9/15/2020	CENTRAL TEXAS BRQ	8173			\$32.99					\$0.00	\$0.00	\$32.99											
9/15/2020	Family Dollar	8065					\$10.83			\$0.00	\$0.00	\$10.83											
9/17/2020	99 Cents Only Store	8065					\$34.74			\$0.00	\$0.00	\$34.74											
9/18/2020	Central Texas BRQ/Conference/Event	8065			\$100.00					\$0.00	\$0.00	\$100.00											
9/18/2020	CVS Pharmacy/Supplies for event	8065					\$4.54			\$0.00	\$0.00	\$4.54											
9/18/2020	Ashley's Donuts	8173			\$62.19					\$0.00	\$0.00	\$62.19											
9/20/2020	Comcast	8173			\$162.80					\$0.00	\$0.00	\$162.80											
SUBTOTAL												\$0.00	\$0.00	\$195.10	\$162.80	\$50.14	\$0.00	\$227.94	\$0.00	\$0.00	\$635.45		
TOTAL EXPENSES												\$0.00	\$0.00	\$0.00	\$0.00	\$0.00	\$0.00	\$0.00	\$0.00	\$0.00	\$0.00	\$0.00	\$0.00
TOTAL EXPENSES												\$0.00	\$0.00	\$0.00	\$0.00	\$0.00	\$0.00	\$0.00	\$0.00	\$0.00	\$0.00	\$0.00	\$0.00

Beth Strope

September 2020

Approved by: Beth Strope

Hobby Area District - Business Expense Report

DATE	ADDRESS & LOCATION (NAME, PURPOSE (Meeting, Supplies, Training, etc.) & EMPLOYER THAT INCURRED INDIVIDUAL & COMPANY NAMES AND SUPPORTING REASON FOR EXPENSE)	ACCOUNT CODE	COMMERCIAL TRANSPORT	HOTEL CHARGES (EXCL. MEALS)	MEALS	PHONE	SUPPLIES	FURNISH & TOLLS	OTHER	Personal Auto Use (Total @ 5¢)	2018 Total @ 5¢	TOTAL											
SUBTOTAL												\$0.00	\$0.00	\$0.00	\$100.00	\$184.76	\$0.00	\$470.00	\$0.00	\$0.00	\$100.00		
TOTAL EXPENSES												\$0.00	\$0.00	\$0.00	\$0.00	\$0.00	\$0.00	\$0.00	\$0.00	\$0.00	\$0.00	\$0.00	\$0.00

Beth Strope

09/24/2020

Approved by:

5.5% IRS Mileage Reimbursement Rate

Paid by Check # 3087





**SEAL Security Solutions LLC**

1525 Blalock Road  
Houston, TX 77080-7318  
www.SEALSecurity.com  
713-979-2388  
TX DPS Lic. #C15942

**Invoice**

Date	Invoice #
9/28/2020	49459

**Bill To**

Hobby Management District  
8121 Broadway, Suite 199  
Houston, TX 77061

Description	Hours	Rate/ Hour	Terms
			Net 30
			Amount
Commissioned Security Officer with Vehicle and K-9	185	31.00	5,735.00
Patrol Period 09/21/2020 through 09/27/2020			
Patrols are billed every Monday for the hours patrolled the week preceding the above invoice date.			
This invoice is Monday through Sunday inclusive.			
NOTE: A 3% convenience fee will be charged on all payments made by credit card.			Sales Tax (8.25%) \$0.00
<b>Thank you for allowing us to earn your business.</b>		<b>Total</b>	<b>\$5,735.00</b>

**Paid by Check # 3089****Equi-Tax Inc.**  
*Ad Valorem Tax Assessors / Collectors*

www.equitasinc.com

17111 Rolling Creek Drive, Suite 200, Houston, Texas 77090  
P. O. Box 73109, Houston, Texas 77273  
Customer Service 281.444.3946 fax 281.440.8304

8/25/2020

7950 BELLFORT LTD  
99 DETERING ST STE 200  
HOUSTON, TX 77007-8259

HOBBY AREA DISTRICT  
ACCOUNT NUMBER: R000200148 / 910402390010051  
LEGAL DESCRIPTION: TR 25A BLK 5 MEADOWBROOK ACRES U/R ABST 27 J R HARRIS  
SITUS: 7950 BELLFORT ST 272  
YEAR: 2019 DATE PROCESSED: 8/25/2020

**NOTICE OF CHANGE IN TAX LIABILITY**

We have been notified by the Appraisal District of a change in the appraisal of your property that has resulted in a change in your tax liability for the 2019 tax year.

The explanation of the change is Lawsuit Cause No.: 2019-70350

This action has resulted in a decrease in the amount you owe. Accordingly, we are issuing you a refund in the amount of \$2,354.00.

Note: Questions regarding the changes in value should be directed to the Appraisal District.

If you need more information, call Customer Service at 281.444.3946.

**Paid by Check # 3090****Equi-Tax Inc.**  
*Ad Valorem Tax Assessors / Collectors*

www.equitasinc.com

17111 Rolling Creek Drive, Suite 200, Houston, Texas 77090  
P. O. Box 73109, Houston, Texas 77273  
Customer Service 281.444.3946 fax 281.440.8304

8/25/2020

APT BROADWAY VILLAGE LLC  
2205 AVENUE I STE 117  
ROSENBERG, TX 77471

HOBBY AREA DISTRICT  
ACCOUNT NUMBER: R000200063 / 910402390000002  
LEGAL DESCRIPTION: TR 34 (BLDGS | THRU 17) WOODLEN GLEN APTS SEC 2 ABST 27 J R HARRIS  
SITUS: 8400 BROADWAY BLVD 210  
YEAR: 2018 DATE PROCESSED: 8/25/2020

**NOTICE OF CHANGE IN TAX LIABILITY**

We have been notified by the Appraisal District of a change in the appraisal of your property that has resulted in a change in your tax liability for the 2018 tax year.

The explanation of the change is Lawsuit Cause No.: 2018-74038

This action has resulted in a decrease in the amount you owe. Accordingly, we are issuing you a refund in the amount of \$1,849.54.

Note: Questions regarding the changes in value should be directed to the Appraisal District.

If you need more information, call Customer Service at 281.444.3946.

**Paid by Check # 3091****Equi-Tax Inc.**  
*Ad Valorem Tax Assessors / Collectors*

www.equitasinc.com

17111 Rolling Creek Drive, Suite 200, Houston, Texas 77090  
P. O. Box 73109, Houston, Texas 77273  
Customer Service 281.444.3946 fax 281.440.8304

8/25/2020

APT BROADWAY VILLAGE LLC  
2205 AVENUE I STE 117  
ROSENBERG, TX 77471-2651

HOBBY AREA DISTRICT  
ACCOUNT NUMBER: R000200063 / 910402390000002  
LEGAL DESCRIPTION: TR 34 (BLDGS | THRU 17) WOODLEN GLEN APTS SEC 2 ABST 27 J R HARRIS  
SITUS: 8400 BROADWAY BLVD 210  
YEAR: 2019 DATE PROCESSED: 8/25/2020

**NOTICE OF CHANGE IN TAX LIABILITY**

We have been notified by the Appraisal District of a change in the appraisal of your property that has resulted in a change in your tax liability for the 2019 tax year.

The explanation of the change is Lawsuit Cause No.: 2019-73808

This action has resulted in a decrease in the amount you owe. Accordingly, we are issuing you a refund in the amount of \$3,372.63.

Note: Questions regarding the changes in value should be directed to the Appraisal District.

If you need more information, call Customer Service at 281.444.3946.

**Paid by Check # 3091**



**Equi-Tax Inc.**  
Ad Valorem Tax Assessors / Collectors

www.equitaxinc.com 17111 Rolling Creek Drive, Suite 200, Houston, Texas 77090  
P. O. Box 73109, Houston, Texas 77273  
8/25/2020 Customer Service 281.444.3946 fax 281.440.8304

FIRST SERVICE CREDIT UNION  
PO BOX 941914  
HOUSTON, TX 77094-8914

HOBBY AREA DISTRICT  
ACCOUNT NUMBER: R000201305 / 911313660010001  
LEGAL DESCRIPTION: RES A BLK 1 HOUSTON ENERGY CREDIT UNION  
SITUS: 8980 CLEARWOOD ST  
YEAR: 2019 DATE PROCESSED: 8/25/2020

**NOTICE OF CHANGE IN TAX LIABILITY**

We have been notified by the Appraisal District of a change in the appraisal of your property that has resulted in a change in you tax liability for the 2019 tax year.

The explanation of the change is Lawsuit Cause No.: 2019-52528

This action has resulted in a decrease in the amount you owe. Accordingly, we are issuing you a refund in the amount of \$16.41.

Note: Questions regarding the changes in value should be directed to the Appraisal District.

If you need more information, call Customer Service at 281.444.3946.

**Paid by Check # 3092**



**Equi-Tax Inc.**  
Ad Valorem Tax Assessors / Collectors

www.equitaxinc.com 17111 Rolling Creek Drive, Suite 200, Houston, Texas 77090  
P. O. Box 73109, Houston, Texas 77273  
8/25/2020 Customer Service 281.444.3946 fax 281.440.8304

LAUREN HOLDINGS  
14 STEVEN LUKE LN  
FRIENDSWOOD, TX 77546

HOBBY AREA DISTRICT  
ACCOUNT NUMBER: R000201212 / 911231740010001  
LEGAL DESCRIPTION: RES A BLK 1 GULF FREEWAY ALMEDA  
SITUS: 11550 GULF FWY  
YEAR: 2018 DATE PROCESSED: 8/25/2020

**NOTICE OF CHANGE IN TAX LIABILITY**

We have been notified by the Appraisal District of a change in the appraisal of your property that has resulted in a change in you tax liability for the 2018 tax year.

The explanation of the change is Lawsuit Cause No.: 2018-68431

This action has resulted in a decrease in the amount you owe. Accordingly, we are issuing you a refund in the amount of \$329.51.

Note: Questions regarding the changes in value should be directed to the Appraisal District.

If you need more information, call Customer Service at 281.444.3946.

**Paid by Check # 3093**



**Equi-Tax Inc.**  
Ad Valorem Tax Assessors / Collectors

www.equitaxinc.com 17111 Rolling Creek Drive, Suite 200, Houston, Texas 77090  
P. O. Box 73109, Houston, Texas 77273  
8/25/2020 Customer Service 281.444.3946 fax 281.440.8304

MPT Interest LLC  
c/o McKenney McClelland PLLC  
2200 North Loop West Ste 333  
Houston, TX 77018

HOBBY AREA DISTRICT  
ACCOUNT NUMBER: R000199948 / 910342030030127  
LEGAL DESCRIPTION: TR 127A SOUTH HOUSTON GARDENS SEC 6  
SITUS:  
YEAR: 2016 DATE PROCESSED: 8/25/2020

**NOTICE OF CHANGE IN TAX LIABILITY**

We have been notified by the Appraisal District of a change in the appraisal of your property that has resulted in a change in you tax liability for the 2016 tax year.

The explanation of the change is Lawsuit Cause No.: 2016-80783

This action has resulted in a decrease in the amount you owe. Accordingly, we are issuing you a refund in the amount of \$207.00.

Note: Questions regarding the changes in value should be directed to the Appraisal District.

If you need more information, call Customer Service at 281.444.3946.

**Paid by Check # 3094**



**Equi-Tax Inc.**  
Ad Valorem Tax Assessors / Collectors

www.equitaxinc.com 17111 Rolling Creek Drive, Suite 200, Houston, Texas 77090  
P. O. Box 73109, Houston, Texas 77273  
8/25/2020 Customer Service 281.444.3946 fax 281.440.8304

STILES PROPERTIES BRANIFF ROAD LTD  
1901 JASMINE DR  
PASADENA, TX 77503-3223

HOBBY AREA DISTRICT  
ACCOUNT NUMBER: R000199773 / 910280590000016  
LEGAL DESCRIPTION: TR 12B ORANGE DALE  
SITUS: 7760 BRANIFF ST  
YEAR: 2019 DATE PROCESSED: 8/25/2020

**NOTICE OF CHANGE IN TAX LIABILITY**

We have been notified by the Appraisal District of a change in the appraisal of your property that has resulted in a change in you tax liability for the 2019 tax year.

The explanation of the change is Lawsuit Cause No.: 2019-73872

This action has resulted in a decrease in the amount you owe. Accordingly, we are issuing you a refund in the amount of \$245.02.

Note: Questions regarding the changes in value should be directed to the Appraisal District.

If you need more information, call Customer Service at 281.444.3946.

**Paid by Check # 3095**





**Equi-Tax Inc.**  
Ad Valorem Tax Assessors / Collectors

www.equitasinc.com 17111 Rolling Creek Drive, Suite 200, Houston, Texas 77090  
P.O. Box 73109, Houston, Texas 77273  
8/25/2020 Customer Service: 281.444.3946 fax: 281.440.8304

VLR TEXAS PROPERTIES LLC  
503 CALISTOGA RD  
SANTA ROSA, CA 95409-3708

HOBBY AREA DISTRICT  
ACCOUNT NUMBER: R000201309 / 911320940010001  
LEGAL DESCRIPTION: RES A BLK J HUTTON  
SITUS: 6951 BELLFORT ST  
YEAR: 2019 DATE PROCESSED: 8/25/2020

**NOTICE OF CHANGE IN TAX LIABILITY**

We have been notified by the Appraisal District of a change in the appraisal of your property that has resulted in a change in your tax liability for the 2019 tax year.

The explanation of the change is Lawsuit Cause No.: 2019-66784

This action has resulted in a decrease in the amount you owe. Accordingly, we are issuing you a refund in the amount of \$53.46.

Note: Questions regarding the changes in value should be directed to the Appraisal District.

If you need more information, call Customer Service at 281.444.3946.

**Paid by Check # 3096**

**Arthur Perez**  
Security and Networking Consulting  
4714 Silver Spruce Lane  
Friendswood, Texas 77546  
632-309-6937

**INVOICE**

INVOICE NO: 200917  
DATE: September 17, 2020

**Bill To:**  
Hobby Area District  
8121 Broadway, Suite 199  
Houston, TX 77061

CUSTOMER	P.O. NUMBER	SERVICE DATE	PROJECT	ONSITE SERVICE	TERMS
HADIST	Verbal	09-2020	006	Yes	NET 30

QUANTITY	DESCRIPTION	UNIT PRICE	AMOUNT
1.00	09/08/2020 Setup O365 Whitelist of Texas811	175.00	175.00
2.00	09/10/2020 Repair email / laptop for D. Perkins due to hack	175.00	350.00
SUBTOTAL			\$525.00
BALANCE FORWARD			.00
<b>TOTAL DUE</b>			<b>\$525.00</b>

**SPECIAL NOTE:**  
Please make check payable to Arthur Perez at above address

If you have any questions concerning this invoice, call me at 832-309-6937

**Paid by Check # 3098**

THANK YOU FOR YOUR BUSINESS!



East End District  
P.O. Box 230099  
Houston, TX 77223 US  
713-928-9916  
eva@eastenddistrict.com

**INVOICE**

**BILL TO**  
Danny Perkins  
Hobby Area Management  
District  
8121 Broadway, Ste. 199  
Houston, Texas 77061

INVOICE # 28-42  
DATE 09/30/2020  
DUE DATE 10/31/2020  
TERMS Net 30

DATE	ACTIVITY	QTY	RATE	AMOUNT
09/04/2020	Field Services Inspections, surveying, and follow-ups	4	35.00	140.00
09/04/2020	Reporting - Field Services Reporting and follow-up.	1	35.00	35.00
09/04/2020	Mileage Reimbursement 68.4 Miles	68.40	0.575	39.33
09/11/2020	Field Services Inspections, surveying, and follow-ups	4	35.00	140.00
09/11/2020	Reporting - Field Services Reporting and follow-up.	2	35.00	70.00
09/11/2020	Mileage Reimbursement 73.3 Miles	73.30	0.575	42.15
09/18/2020	Field Services Inspections, surveying, and follow-ups	4	35.00	140.00
09/18/2020	Reporting - Field Services Reporting and follow-up.	2	35.00	70.00
09/18/2020	Mileage Reimbursement 68.2 Miles	68.20	0.575	39.22
09/30/2020	Field Services Inspections, surveying, and follow-ups	4	35.00	140.00
09/30/2020	Reporting - Field Services Reporting and follow-up.	2	35.00	70.00
09/30/2020	Mileage Reimbursement 67.0 Miles	67	0.575	38.53

BALANCE DUE **\$964.23**

**Paid by Check # 3099**

**Equi-Tax Inc.**

Suite 200  
17111 Rolling Creek Drive  
Houston Texas 77090  
281-444-4866

**Invoice**

DATE	INVOICE #
10/1/2020	55975

BILL TO
Hobby Area District c/o Bracewell LLP Suite 2300 711 Louisiana Street Houston TX 77002-2770

DESCRIPTION	AMOUNT
Monthly Assessor Services fee per Contract	2,568.84
Roll Management	300.00

**Total \$2,868.84**

**Paid by Check # 3100**

# Governmental Financial Reporting, LLC

1525 Lakeville Drive, Suite 121  
Kingwood, TX 77339  
(281) 348-9151  
FAX (281) 348-9199

10/1/2020

Hobby Area District  
8121 Broadway Blvd, Ste 199  
Houston, TX 77061

For Professional Services Rendered

Bookkeeping services provided during September 2020 for the month of October 2020	1,000.00
Postage and Deliveries	52.04
Mileage - Virtual Board Meeting	0.00

\$1,052.04

**Paid by Check # 3101**

## Office Systems of Texas

104 Lockhaven Dr Houston, TX 77073  
P: 281 443-2996 F: 281 443-1494



### CONTRACT INVOICE

Invoice Number: 471803  
Invoice Date: 09/22/2020

Bill To: Hobby Area District  
8121 Broadway St # 199  
Houston, TX 77061

Customer: Hobby Area District  
8121 Broadway St # 199  
Houston, TX 77061

Account No	Payment Terms	Due Date	Invoice Total	Balance Due
HAG2	Net Due 30 days	10/22/2020	\$80.02	<b>\$80.02</b>

Invoice Remarks

Contract Number	Contract	Contract Amount	P.O. Number	Start Date	Exp. Date
CONF4623-01	Beth Strope 832 982-2048	\$80.02		04/24/2017	

Contract Remarks

We at Office Systems of Texas appreciate your business.

**Summary:**

Contract base rate charge for the 08/24/2020 to 09/23/2020 billing period	\$36.00
Contract coverage charge for the 08/24/2020 to 09/23/2020 coverage period	\$44.02**
**See coverage details below	\$80.02

#### Equipment included under this contract

**Konica Minolta/C458**

Number	Serial Number	Base Adj.	Location
2154	A79M011004884	\$0.00	Hobby Area District 8121 Broadway St #199 Houston, TX 77061

Meter Type	Meter Group	Begin Meter	End Meter	Credits	Total	Covered	Billable	Rate	Overage
B/W	B/W	52,908	52,963		55	2,500	0	\$0.014000	\$0.00
Color	Color	65,269	65,793		524	0	524	\$0.084000	\$44.02
									\$44.02

\*\*\* You can now order supplies and place service calls at [www.osot.com](http://www.osot.com) \*\*\*

If you prefer to receive your invoices via email or make payments via ACH please call us or email [deborah@osot.com](mailto:deborah@osot.com) to set up your account.

Thank you for your business

Invoice SubTotal	\$80.02
Tax	\$0.00
Invoice Total	\$80.02
<b>Balance Due:</b>	<b>\$80.02</b>

**KONICA MINOLTA** **Paid by Check # 3103** Page 1 of 1  
Authorized Dealer Since 1977



GreatAmerica Financial Svcs.  
PO Box 660831  
Dallas, TX 75266-0831

FORWARDING SERVICE REQUESTED

Check here for change of address (see reverse for details)

ATTN: ACCOUNTS PAYABLE  
HOBBY AREA DISTRICT  
8121 BROADWAY ST # 199  
HOUSTON TX 77061-1340

### Remittance Section

Invoice Number: 27902451  
Agreement Number: 013-1245091-000  
Invoice Print Date: 09/29/2020  
Due Date: 10/24/2020  
Current Charges: \$383.26  
Past Due Amount: \$383.26  
Total Due: **\$766.52**

Use enclosed envelope and make check payable to:

GreatAmerica Financial Svcs.  
PO Box 660831  
Dallas, TX 75266-0831



0000131245091000000000279024510000000000766521

Keep lower portion for your records - Please return upper portion with your payment



GreatAmerica Financial Svcs.  
PO Box 660831  
Dallas, TX 75266-0831

Invoice Number: 27902451  
Due Date: 10/24/2020  
Total Due: **\$766.52**

### Important Messages

Your payment is past due. Please remit the total due.

If you wish to complete a check-by-phone payment, please call the customer support number on this invoice. This option is provided to you for a nominal fee.

### Invoice Detail

Agreement 013-1245091-000: Konica Minolta C458 with PC-415 Paper Feed Cabinet	Amount	Tax	Total
1 Later Charges For 09/29/2020	34.84	0.00	34.84
2 Standard Payment	348.42	0.00	348.42
			<b>\$383.26</b>

Subtotal of Current Charges **\$383.26**

Summary of Past Due Charges	Amount
Invoice 27717431 - Due 09/24/2020	383.26

Subtotal of Past Due Charges **\$383.26**

For more information about your invoice, please:  
- Call us at 866-339-9781  
- Email us at [customersupport-01@accountservicing.com](mailto:customersupport-01@accountservicing.com)  
- Visit [www.AccountServicing.com](http://www.AccountServicing.com)  
- (Para Español, pida la extensión 2344.)

**Total Due \$766.52**

Domestic Checks, Drafts Or Orders Spell Be Subject To A Surcharge Of 0.20

**Paid by Check # 3102**

Invoice # 27902451

For more information about your invoice, please call us at 866-339-9781 or email at [customersupport-01@accountservicing.com](mailto:customersupport-01@accountservicing.com)

Page 1



P.O. Box 1875  
Houston, TX 77251-1875

### INVOICE

Date	Invoice #
9/20/2020	106707

### Bill To:

Hobby Area District  
Beth Strope  
8121 Broadway  
Suite 199  
Houston, Texas 77061 USA

Customer Contact:

**Beth Strope**

Project Name

Sticker for Envelope

P.O. No.	Terms	Project
	Due on receipt	20HAD004

Quantity	Description	Rate	Amount
1	Layout (Priority Service)	100.00	100.00
	Printing of 500 Stickers	273.32	273.32
	Delivery to Client (Houston, Texas)	35.00	35.00
	Customer Discount Non-Taxable	-25.00	-25.00
<b>Total</b>			<b>\$383.32</b>

Thank you for your business.

**Paid by Check # 3104**





P.O. Box 1875  
Houston, TX 77251-1875

**INVOICE**

Date	Invoice #
9/20/2020	106708

**Bill To:**

Hobby Area District  
Beth Strope  
8121 Broadway  
Suite 199  
Houston, Texas 77061 USA

**Customer Contact:**

Beth Strope

Project Name	P.O. No.	Terms	Project
Distribution Event Flyer/Graphic		Due on receipt	20HAD003

Quantity	Description	Rate	Amount
1	Design and Layout (Priority Service) Includes custom clipart illustration.	500.00	500.00
	Extended Customer Discount Non-Taxable	-250.00	-250.00
Thank you for your business.		<b>Total</b>	<b>\$250.00</b>

Paid by Check # 3104

Beth Strope



Tribe Design  
PO Box 1875  
Houston, TX 77251-1875

**PURCHASE ORDER**

P.O. # 0000012  
Date 09/07/2020

Item	Description	Unit Price	Quantity	Amount
Service	Graphic Design and Layout for social media and yard signs (distribution event)	1.00	250.00	250.00
Service	Printing and delivery of 10 yard signs for distribution event	1.00	432.98	432.98
Service	Printing and delivery of COVID bag logo stickers (distribution event)	1.00	383.32	383.32
Service				
<b>Subtotal</b>				<b>1,066.30</b>
<b>Total</b>				<b>1,066.30</b>
<b>Amount Paid</b>				<b>0.00</b>
<b>P.O. Total</b>				<b>\$1,066.30</b>

NOTES: Branding, social media graphics and signage for HAD Distribution event.

Approved: *Beth Strope*

Approved: *[Signature]*



P.O. Box 1875  
Houston, TX 77251-1875

**INVOICE**

Date	Invoice #
9/20/2020	106709

**Bill To:**

Hobby Area District  
Beth Strope  
8121 Broadway  
Suite 199  
Houston, Texas 77061 USA

**Customer Contact:**

Beth Strope

Project Name	P.O. No.	Terms	Project
Distribution Event Sign		Due on receipt	20HAD003

Quantity	Description	Rate	Amount
1	Printing of Ten (10) Signs	322.98	322.98
	Layout and Reformatting (Priority Service)	100.00	100.00
	Delivery to Client (Houston, Texas)	35.00	35.00
	Customer Discount Non-Taxable	-25.00	-25.00
Thank you for your business.		<b>Total</b>	<b>\$432.98</b>

Paid by Check # 3104



**Billing Statement**

For Period 10/01/20 to 10/31/20  
Statement Date: 09/15/20

Payment Received 08/29/20	-33.32
No Outstanding Balance As Of 9/16/20	0.00
Current Premiums	118.89
<b>Total Payment Due 10/01/20</b>	<b>\$118.89</b>

Approval: \_\_\_\_\_  
"Insurable use only"

**Summary of Activity this Period**

Coverage	Previous	Adm.	Comm.	Current	Current	Premium	Premium
	Rate	Rate	Rate	Rate	Rate	Rate	Rate
Group Term Life	1	0	0	1	1	\$40.00	\$0.00
General	1	0	0	1	1	\$20.00	\$0.00
Auto	1	0	0	1	1	\$25.00	\$0.00
Medical	1	0	0	1	1	\$28.89	\$0.00
<b>TOTAL</b>						<b>\$113.89</b>	<b>\$0.00</b>

**Summary of Current Premiums by Rate Class**

Coverage	Emp.	Total
Group Term Life	\$40.00	\$14.00
General	\$20.00	\$40.00
Auto	\$25.00	\$25.00
Medical	\$28.89	\$28.89
<b>TOTAL</b>	<b>\$113.89</b>	<b>\$118.89</b>

**Planholder Reference**

PAMELA GUERRA  
HOBBY AREA DISTRICT  
Group ID: 00 786557  
Division ID: 0000

RND\_BF  
AGG\_003  
A/R:1917

**Questions!**

Log on to [www.guardiankeylines.com](http://www.guardiankeylines.com)  
Check or make changes to members' eligibility, view and pay bills and more.  
Log on or register in our calculator at [www.guardiankeylines.com](http://www.guardiankeylines.com)

Due Date: 10/01/20  
Payment Due: \$118.89  
Please do not write on covered copies. If you have changes, please submit them to Guardian Keylines or submit an automatic payment and be automatically debited on 10/01/20.  
Group ID: 00 786557  
Division: 0000

Guardian Payment Notice



HOBBY AREA DISTRICT  
8121 BROADWAY STE 199  
HOUSTON, TX 77061

# Invoice

HAWES HILL & ASSOCIATES  
P.O. Box 22167  
Houston TX 77227-2167



Invoice #: 43016441  
Date: 10/1/2020

Bill To:  
Hobby Area Management District (HCID #9)  
8121 Broadway, Suite 199  
Houston, TX 77061

Description	Amount
Professional consulting and administration fee, September 2020	\$9,000.00

Your Order #:	Total Amount:	\$9,000.00
	Amount Applied:	\$0.00
	Balance Due:	\$9,000.00
<b>Paid by Check # 3104</b>		



# HOBBY AREA DISTRICT

(HARRIS COUNTY IMPROVEMENT DISTRICT NO. 9)  
CITY OF HOUSTON  
HARRIS COUNTY, TEXAS

---

---

## AGENDA MEMORANDUM

---

---

To: Hobby Area District Board of Directors  
From: Executive Director  
Subject: Agenda Item Materials

---

5. Receive Assessments Collection and Delinquency Report.

**HOBBY AREA DISTRICT  
ASSESSMENT COLLECTION REPORT  
September 2020  
BILLING AND COLLECTION SUMMARY  
FISCAL YEAR  
01/01/2020 - 12/31/2020**

YEAR	RATE	TOTAL LEVY	COLLECTIONS	RECEIVABLE	% COLLECTED
2019	0.15000	\$2,001,564.75	\$1,973,561.06	\$28,003.69	99%
2018	0.15000	\$1,860,081.19	\$1,845,384.12	\$14,697.07	99%
2017	0.15000	\$1,785,571.35	\$1,779,921.77	\$5,649.58	99%
2016	0.15000	\$1,738,267.86	\$1,736,368.11	\$1,899.75	99%
2015	0.15000	\$1,685,910.78	\$1,684,740.37	\$1,170.41	99%
2014	0.15000	\$1,524,784.44	\$1,523,869.76	\$914.68	99%
2013	0.15000	\$1,358,121.73	\$1,356,800.12	\$1,321.61	99%

Current Month Activity

Revenue:	<u>Current Month</u>	<u>Year to Date</u>
2019 Assessment Collected	1,643.74	1,875,964.37
2018 Assessment Collected	115.43	3,378.06
2017 Assessment Collected	112.31	614.11
2016 Assessment Collected	2.60	-74.58
2015 Assessment Collected	0.00	136.98
2014 Assessment Collected	0.00	135.51
2013 Assessment Collected	0.00	132.75
Penalty & Interest	407.43	19,472.92
Overpayments	0.00	4,027.02
CAD Lawsuits	0.00	55,756.59
CAD Corrections	0.00	2,108.28
Collection Fees	456.30	7,849.51
Court Fees	0.00	0.00
Miscellaneous Revenue	0.00	25.73
Estimated Payments	0.00	0.00
<b>Total Revenue</b>	<b>2,737.81</b>	<b>1,969,527.25</b>
Overpayments Presented for Refund	8,182.55	62,115.41
Overpayments Applied to Assessment	0.00	0.00

ASSESSED VALUE FOR 2013:	<b>919,950,929</b>	Uncertified:	<b>0</b>
ASSESSED VALUE FOR 2014:	<b>1,029,864,792</b>	Uncertified:	<b>0</b>
ASSESSED VALUE FOR 2015:	<b>1,137,542,865</b>	Uncertified:	<b>0</b>
ASSESSED VALUE FOR 2016:	<b>1,176,150,257</b>	Uncertified:	<b>0</b>
ASSESSED VALUE FOR 2017:	<b>1,217,116,826</b>	Uncertified:	<b>654,390</b>
ASSESSED VALUE FOR 2018:	<b>1,263,405,698</b>	Uncertified:	<b>654,390</b>
ASSESSED VALUE FOR 2019:	<b>1,364,806,869</b>	Uncertified:	<b>3,447,321</b>

Assessment Collection Account: Wells Fargo, Account No. 3402018257

**ASSESSMENT PLAN PROJECTIONS**

YEAR	CURRENT RATE	PROJECTED LEVY	COLLECTIONS	CUMULATIVE	10 YEAR AVERAGE
		2%	@ 95%	COLLECTIONS	
2013	0.15000	1,358,122	1,290,216	\$1,356,800.12	
2014	0.15000	1,385,284	1,316,020	\$1,523,869.76	
2015	0.15000	1,412,990	1,342,340	\$1,684,740.37	
2016	0.15000	1,441,250	1,369,187	\$1,736,368.11	
2017	0.15000	1,470,075	1,396,571	\$1,779,921.77	
2018	0.15000	1,499,476	1,424,502	\$1,845,384.12	
2019	0.15000	1,529,466	1,452,992	\$1,973,561.06	
2020	0.15000	1,560,055	1,482,052		
2021	0.15000	1,591,256	1,511,693		
2022	0.15000	1,623,081	1,541,927		
		14,871,054	26,028,147		1,487,105

The Projected Levy is based on the rate remaining at 0.15000

Prepared by: Equi-Tax Inc.  
Collector for the District

**HOBBY AREA DISTRICT**

**September 2020**

**TOP TEN ASSESSMENT PAYERS**

<b>PROPERTY OWNER</b>	<b>ACCOUNT NOS</b>	<b>SITUS</b>	<b>PROPERTY TYPE</b>	<b>VALUE</b>	<b>ASSESSMENT</b>
VERDE COMMUNITIES LLC 440 N WELLS ST STE 410 CHICAGO, IL 60654-4975	1097860000001	8751 BROADWAY ST #213 77061	MULTI-FAMILY	73,835,500	110,753.25
	1097860000002	7900 MORLEY ST #292 77061			
	1097860000003	8801 GLENCREST ST #322 77061			
	1097890000008	8950 GLENCREST ST #200 77061			
	0402390000108	8750 BROADWAY ST #222 77061			
	1141750000001	8955 BROADWAY ST #208 77061			
	0402390000101	8200 BROADWAY ST #224 77061			
	1097870000007	8900 GLENCREST ST #208 77061			
	1141690000001	8915 BROADWAY ST #200 77061			
	0402390000100	8501 BROADWAY ST #380 77061			
ARCP MT HOUSTON TX LLC 2325 E CAMELBACK RD STE 1100 PHOENIX AZ 85016-9078	1258210010001	0 MELDRUM 77075	WAREHOUSE STORE	34,684,315	51,703.56
	1260630010012	0 ROWLETT ST 77075			
	1260630010005	10013 ALMEDA GENOA RD 77075			
	1260630010006	10025 ALMEDA GENOA RD 77075			
	1260630010010	10009 ALMEDA GENOA RD 77075			
1260630010011	0 MELDRUM 77075				
INLAND DIVERSIFIED HOUSTON OREM LLC ATTN PM DEPT 4714 11995 EL CAMINO REAL SAN DIEGO CA 92130-2539	1307400010001	6905 E OREM DR 77075	WAREHOUSE	23,192,492	23,967.01
	1296790010001	6903 E OREM DR 77075			
VIVA PROPERTIES LLC P O BOX 405 LOLITA TX 77971-0405	0971580000001	0 VILLA DR 77061	WAREHOUSE	22,296,563	33,444.84
	1199160010001	0 NEUHAUS AVE 77061			
	0971580000002	8300 TEWANTIN DR			
ATRIUM FINANCE II LP MARRIOT HOBBY 4243 HUNT RD BLUE ASH OH 45242-6645	0342030040003	9100 GULF FWY 77061	HOTEL	21,688,027	32,532.04
	0342030020130	9100 GULF FWY 77061			
	0342030020118	9100 GULF FWY #287 77017			
GALILEO APOLLO III TX LP 3901 BELLAIRE BLVD HOUSTON TX 77025-1100	1254930010002	10235 ALMEDA GENOA RD 77034	RETAIL CENTER	18,731,027	28,096.54
	1254930010001	10225 ALMEDA GENOA RD 77034			

**HOBBY AREA DISTRICT**

<b>September 2020</b>					
<b>TOP TEN ASSESSMENT PAYERS</b>					
1859 HISTORIC HOTELS LTD 2302 POST OFFICE ST GALVESTON TX 77550-1935	0963850000001 0963850000003	8181 AIRPORT BLVD #303 77061 0 RUTHBY 77061	HOTEL	18,434,540	27,651.81
POWELL ELECTRICAL SYSTEMS LLC 8550 MOSLEY RD HOUSTON TX 77075-1116	1193970010001	7232 AIRPORT BLVD 77061	MANUFACTURING	18,389,106	27,583.66
OREILLY AUTO ENTERPRISES LLC 233 S PATTERSON AVE SPRINGFIELD MO 65802-2210	0342070120005 1250380010001	8601 TAVENOR LN 77075 8910 TAVENOR LN 77075	WAREHOUSE	17,757,206	26,635.81
C G 7600 LP % GARVER 1901 LEXINGTON ST HOUSTON TX 77098-4219	0421910000006 0421910000117	7600 S SANTA FE DR 77061 7600 S SANTA FE DR 77061	WAREHOUSE	17,284,204	25,926.31



**HOBBY AREA DISTRICT**

**September 2020**

**TOP TEN DELINQUENT ACCOUNTS**

<b>PROPERTY OWNER</b>	<b>ACCOUNT NO</b>	<b>SITUS</b>	<b>PROPERTY TYPE</b>	<b>ASSESSMENT YEAR(S)</b>	<b>ASSESSMENT</b>
INDUSTRIAL SURPLUS INC 6532 RUPLEY CIR HOUSTON TX 77087-3442	91 048 001 000 0195	9200 TELEPHONE RD 77075	INDUSTRIAL	2017 - 2018	6,054.71
HAMS AVIATION MAINTENANCE SRV INC 7766 BRANIFF ST HOUSTON TX 77061-5120	91 043 228 000 0031	8703 TELEPHONE RD 77061	STORAGE HANGAR	2013 - 2019	5,454.19
FURNITURE BANK 8220 MOSLEY RD HOUSTON TX 77075-1110	91 034 203 002 0122	8220 MOSLEY RD 77075	WAREHOUSE	2018	4,546.44
RBIP TRANSPORTATION LLC 6750 BENDER RD HUMBLE TX 77396-2107	91 034 207 011 0025	9201 TAVENOR LN 77075	WAREHOUSE	2019	2,084.98
ALFE PROPERTIES LLC 8303 HANSEN RD HOUSTON TX 77075-1003	91 034 203 002 0107	8303 HANSEN RD 77075	WAREHOUSE	2019	2,043.00
BLACKBURN INSTRUMENTS CO 7525 WYNLEA ST HOUSTON TX 77061-2833	91 040 239 000 0050	7525 WYNLEA ST 77061	WAREHOUSE	2019	1,334.52
CASTILLO WALTER S 14432 BONHAM ST HOUSTON TX 77015-5308	91 076 121 004 0015	7614 PECAN VILLAS DR 77061	SHOPPING CENTER	2016 - 2019	1,313.28
STMS INC DBA SOUTH TEXAS ADULT DAY ACTIVITY CENTER 2602 GRANITE CT PEARLAND TX 77584-9155	91 070 072 027 0017	6011 TELEPHONE RD 77087	DAY CARE CENTER	2017 - 2019	1,280.70
KCS HOLDINGS INC 1527 SKINNER RD HOUSTON TX 77093-4022	91 034 203 003 0172	9225 SCRANTON ST 77075	SINGLE FAMILY RESIDENCE	2018 - 2019	1,214.30
APARTMENTS AT 4114 BROADWAY LLC 2260 W HOLCOMBE BLVD STE 281 HOUSTON TX 77030-2008	91 028 301 000 0016	4114 BROADWAY ST #29 77087	APARTMENT GARDEN	2019	1,067.30
* Pending HCAD Value Lawsuits					

**Hobby Area District  
Lawsuit and Arbitration Status Detail as of 8/7/2020**

Jur 943

Tax Year	CAD Account No.	Owner Name	ARB Hearing Value	Assessment Collected	Cause Number	Date Received from HCAD	Settled Value	Reduction in Assessment	% Reduction in Assessment	Date Designation Form Sent to Owner	Date Refund Notice Sent to Bkpr
<b>Tax Year 2016</b>											
<b>Settled</b>											
Tax Year 2016	034-203-002-0100	Sexton Interests Ltd	2,035,314	\$3,052.97	2016-67130	2/26/2020	1,700,000	\$502.97	16.47%	2/26/2020	3/30/2020
Tax Year 2016	064-215-000-0053	CG Gulf Freeway LLC	1,350,019	\$2,025.03	2016-71724	2/26/2020	1,320,000	\$45.03	2.22%	2/26/2020	3/20/2020
Tax Year 2016	062-031-005-0005	Kainer Expt Crating Inc	1,118,957	\$1,678.44	2016-80596	1/28/2020	1,050,000	\$103.44	6.16%	Received	3/2/2020
Tax Year 2016	034-203-003-0127	MPT Interest LLC	1,158,000	\$1,737.00	2016-80783	8/20/2020	1,020,000	\$207.00	11.92%	8/26/2020	9/28/2020
			311,575,071				272,434,202				
			96								
<b>Unsettled</b>											
<b>Tax Year 2016</b>	<b>Total</b>	<b>Unsettled Accounts, original value</b>	<b>0</b>								
<b>Tax Year 2016</b>	<b>Total</b>	<b>Unsettled Accounts, number of accounts</b>	<b>0</b>								
<b>Tax Year 2017</b>											
<b>Settled</b>											
Tax Year 2017	034-203-001-0010	Clarke Distributing LLC	881,762	\$1,322.64	2017-69461	6/19/2020	850,000	\$47.64	3.60%	6/23/2020	8/3/2020
			272,568,091				243,591,342				
			76								
<b>Unsettled</b>											
Tax Year 2017	096-294-000-0001	Heritage Gulf Coast LLC	3,602,464		2017-69192						
Tax Year 2017	096-294-000-0003	Heritage Gulf Coast LLC	12,606		2017-78745						
Tax Year 2017	096-294-000-0004	Heritage Gulf Coast LLC	1,185,957		2017-78745						
Tax Year 2017	132-245-001-0001	Heritage Gulf Coast LLC	843,386		2017-78745						
<b>Tax Year 2017</b>	<b>Total</b>	<b>Unsettled Accounts, original value</b>	<b>5,644,413</b>								
<b>Tax Year 2017</b>	<b>Total</b>	<b>Unsettled Accounts, number of accounts</b>	<b>4</b>								



**Hobby Area District  
Lawsuit and Arbitration Status Detail as of 8/7/2020**

Jur 943

Tax Year	CAD Account No.	Owner Name	ARB Hearing Value	Assessment Collected	Cause Number	Date Received from HCAD	Settled Value	Reduction in Assessment	% Reduction in Assessment	Date Designation Form Sent to Owner	Date Refund Notice Sent to Bkpr
<b>Tax Year 2018</b>											
<b>Settled</b>											
Tax Year 2018	034-203-001-0010	Clarke Distributing LLC	901,793	\$1,352.69	2018-71785	6/19/2020	870,000	\$47.69	3.53%	6/23/2020	8/3/2020
Tax Year 2018	062-031-005-0005	Kainer Expt Crating Inc	1,117,575	\$1,676.36	2018-72266	6/19/2020	1,100,000	\$26.36	1.57%	Received	8/3/2020
Tax Year 2018	046-205-000-0021	NPA III Hotel Group LLC	5,917,175	no change	2018-74176	6/19/2020	5,917,175	\$0.00	0.00%	na	na
Tax Year 2018	040-239-001-0009	Cardena Adans	1,833,541	no change	2018-74517	6/19/2020	1,833,541	\$0.00	0.00%	na	na
Tax Year 2018	034-203-002-0192	Reynolds Tony Rex & Janice	895,205	no change	2018-75646	6/19/2020	895,205	\$0.00	0.00%	na	na
Tax Year 2018	123-174-001-0001	Lauren Holdings	2,739,675	\$4,109.51	2018-68431	8/20/2020	2,520,000	\$329.51	8.02%	Received	9/28/2020
Tax Year 2018	040-239-000-0002	Apt Broadway Village LLC	5,756,467	\$8,634.70	2018-74038	8/20/2020	4,523,442	\$1,849.54	21.42%	8/26/2020	9/28/2020
			350,914,237				317,056,775				
			93								
<b>Unsettled</b>											
Tax Year 2018	096-294-000-0001	Heritage Gulf Coast LLC	3,882,330			2017-69192					
Tax Year 2018	096-294-000-0003	Heritage Gulf Coast LLC	12,575			2017-78745					
Tax Year 2018	096-294-000-0004	Heritage Gulf Coast LLC	1,273,989			2017-78745					
Tax Year 2018	132-245-001-0001	Heritage Gulf Coast LLC	850,972			2017-78745					
Tax Year 2018	040-239-001-0020	Smith Jim R	2,306,986			2018-59994					
Tax Year 2018	040-239-001-0038	Smith Jim R	750,000			2018-60630					
Tax Year 2018	096-318-000-0007	Discount Rags Properties LLC	3,598,729			2018-61104					
Tax Year 2018	028-059-000-0016	Stiles Properties Braniff Road Ltd	1,697,100			2018-65344					
Tax Year 2018	136-453-001-0001	Telephone Square LLC	7,519,783			2018-67518					
Tax Year 2018	096-321-000-0004	Pingree 2000 Real Estate Holdings	3,517,502			2018-67607					
Tax Year 2018	040-239-000-0041	2ML Real Estate Interests Inc	2,411,364			2018-68687					
Tax Year 2018	129-096-001-0001	Standard Morgan Partners Ltd	2,046,572			2018-68703					
Tax Year 2018	078-051-001-0007	Grace Business Investments LLC	5,923,328			2018-69515					
Tax Year 2018	062-031-008-0004	Garza Norberto / Askew Mellanie	560,000			2018-71743					
Tax Year 2018	062-031-010-0001	Garza Norberto / Askew Mellanie	705,000			2018-71743					
Tax Year 2018	060-014-023-0038	Priya Holdings LLC	596,955			2018-71881					
Tax Year 2018	065-050-005-0004	Bradley Harry E Estate	673,502			2018-72306					
Tax Year 2018	096-318-000-0006	Nitro Phos Inc	2,902,155			2018-72810					
Tax Year 2018	040-239-000-0011	Broadway Bellfort Prop LLC	3,603,297			2018-72925					
Tax Year 2018	062-031-002-0011	Maraldo Mike	696,000			2018-73458					
Tax Year 2018	060-077-009-0004	CWD Interests LLC	1,320,548			2018-74144					
Tax Year 2018	040-239-000-0058	BBK Properties LLC	237,000			2018-74965					
Tax Year 2018	118-275-001-0001	Maankee Hospitality LLC	3,513,932			2018-75462					
Tax Year 2018	076-121-004-0016	Bah Texas LP	160,000			2018-75702					
Tax Year 2018	120-681-001-0001	Mambo Holdings LP	1,772,000			2019-28490					
<b>Tax Year 2018</b>	<b>Total</b>	<b>Unsettled Accounts, original value</b>	<b>52,531,619</b>								
<b>Tax Year 2018</b>	<b>Total</b>	<b>Unsettled Accounts, number of accounts</b>	<b>25</b>								

**Hobby Area District  
Lawsuit and Arbitration Status Detail as of 8/7/2020**

Jur 943

Tax Year	CAD Account No.	Owner Name	ARB Hearing Value	Assessment Collected	Cause Number	Date Received from HCAD	Settled Value	Reduction in Assessment	% Reduction in Assessment	Date Designation Form Sent to Owner	Date Refund Notice Sent to Bkpr
<b>Tax Year 2019</b>											
<b>Settled</b>											
Tax Year 2019	034-203-003-0170	Hobby Warehouse Center LLC	1,600,000	\$2,400.00	101-19-001843	6/19/2020	877,641	\$1,083.54	45.15%	Received	8/3/2020
Tax Year 2019	034-203-002-0099	CCI Hobby I LP	3,700,000	\$5,550.00	2019-60952	6/19/2020	3,450,500	\$374.25	6.74%	Received	8/3/2020
Tax Year 2019	034-203-003-0123	Comerica Bank	2,446,788	\$3,670.18	2019-65864	6/19/2020	2,147,316	\$449.21	12.24%	6/23/2020	8/3/2020
Tax Year 2019	129-785-001-0004	Kucinski Family Trust	978,525	\$1,467.79	2019-65864	6/19/2020	858,061	\$180.70	12.31%	6/23/2020	8/3/2020
Tax Year 2019	126-063-001-0010	ARCP MT Houston TX LLC	1,446,342	\$2,169.51	2019-66230	6/19/2020	1,286,270	\$240.11	11.07%	Received	8/3/2020
Tax Year 2019	129-578-001-0002	Capview Income & Value Fund IV LP	1,170,154	\$1,755.23	2019-66436	6/19/2020	1,012,144	\$237.01	13.50%	6/23/2020	8/3/2020
Tax Year 2019	129-785-001-0001	Advance Stores Company Inc 8094	739,577	\$1,109.37	2019-66785	6/19/2020	666,056	\$110.29	9.94%	6/23/2020	8/3/2020
Tax Year 2019	034-203-001-0010	Clarke Distributing LLC	932,000	\$1,398.00	2019-67999	6/19/2020	890,000	\$63.00	4.51%	6/23/2020	8/3/2020
Tax Year 2019	096-321-000-0004	Pingree 2000 Real Estate Holdings	3,613,768	\$5,420.65	2019-70056	6/19/2020	3,425,000	\$283.15	5.22%	6/23/2020	8/3/2020
Tax Year 2019	034-203-001-0324	Medallion Investment IV	4,399,898	\$6,599.85	2019-72141	6/19/2020	3,800,000	\$899.85	13.63%	Received	7/1/2020
Tax Year 2019	119-602-001-0001	Syndex Corporation	7,800,000	\$11,700.00	2019-63820	7/20/2020	6,000,000	\$2,700.00	23.08%	7/23/2020	8/3/2020
Tax Year 2019	043-228-000-0073	Friedkin Realty Hobby Airport	3,584,128	\$5,376.19	2019-65785	7/20/2020	3,400,000	\$276.19	5.14%	7/23/2020	8/3/2020
Tax Year 2019	040-239-000-0005	Global New Millennium Partners Ltd	370,096	\$555.14	2019-66176	7/20/2020	316,188	\$80.86	14.57%	Received	8/3/2020
Tax Year 2019	119-800-001-0001	Ghormley Cecil D	2,712,061	\$4,068.09	2019-77449	7/20/2020	2,350,000	\$543.09	13.35%	7/23/2020	8/3/2020
Tax Year 2019	040-239-000-0100	Verde Communities LLC	10,256,380	\$15,384.57	2019-49259	8/20/2020	8,775,547	\$2,221.25	14.44%	Received	9/1/2020
Tax Year 2019	040-239-000-0101	Verde Communities LLC	6,827,410	\$10,241.12	2019-49259	8/20/2020	5,841,656	\$1,478.64	14.44%	Received	9/1/2020
Tax Year 2019	040-239-000-0108	Verde Communities LLC	6,827,400	\$10,241.10	2019-49259	8/20/2020	5,841,648	\$1,478.63	14.44%	Received	9/1/2020
Tax Year 2019	109-786-000-0001	Verde Communities LLC	6,648,690	\$9,973.04	2019-49259	8/20/2020	5,688,740	\$1,439.93	14.44%	Received	9/1/2020
Tax Year 2019	109-786-000-0002	Verde Communities LLC	8,217,840	\$12,326.76	2019-49259	8/20/2020	7,031,334	\$1,779.76	14.44%	Received	9/1/2020
Tax Year 2019	109-786-000-0003	Verde Communities LLC	8,849,980	\$13,274.97	2019-49259	8/20/2020	7,572,204	\$1,916.66	14.44%	Received	9/1/2020
Tax Year 2019	109-787-000-0007	Verde Communities LLC	6,787,720	\$10,181.58	2019-49259	8/20/2020	5,807,697	\$1,470.03	14.44%	Received	9/1/2020
Tax Year 2019	109-787-000-0008	Verde Communities LLC	6,707,590	\$10,061.38	2019-49259	8/20/2020	5,739,136	\$1,452.68	14.44%	Received	9/1/2020
Tax Year 2019	114-169-000-0001	Verde Communities LLC	6,442,020	\$9,663.03	2019-49259	8/20/2020	5,511,910	\$1,395.17	14.44%	Received	9/1/2020
Tax Year 2019	114-175-000-0001	Verde Communities LLC	6,270,470	\$9,405.70	2019-49259	8/20/2020	5,365,128	\$1,358.01	14.44%	Received	9/1/2020
Tax Year 2019	131-366-001-0001	First Service Credit Union	1,105,160	\$1,657.74	2019-52528	8/20/2020	1,094,219	\$16.41	0.99%	8/26/2020	9/28/2020
Tax Year 2019	078-071-001-0002	F&S Grahamcrest LLC	2,790,000	capped	2019-63366	8/20/2020	2,450,000	na	na	na	na
Tax Year 2019	122-722-001-0001	Damij Ltd	3,584,701	\$5,377.05	2019-64486	8/20/2020	2,600,000	\$1,477.05	27.47%	Received	9/1/2020
Tax Year 2019	132-094-001-0001	VLR Texas Properties LLC	627,406	\$941.11	2019-66784	8/20/2020	591,764	\$53.46	5.68%	8/26/2020	9/28/2020
Tax Year 2019	040-239-001-0051	7950 Bellfort Ltd	10,569,335	\$15,854.00	2019-70350	8/20/2020	9,000,000	\$2,354.00	14.85%	8/26/2020	9/28/2020
Tax Year 2019	034-203-002-0192	Reynolds Tony Rex & Janice	895,205		2019-71776		840,000				
Tax Year 2019	040-239-000-0002	APT Broadway Village LLC	7,193,707	\$10,790.56	2019-73808	8/20/2020	4,945,284	\$3,372.63	31.26%	8/26/2020	9/28/2020
Tax Year 2019	028-059-000-0016	Stiles Properties Braniff Road Ltd	1,813,350	\$2,720.02	2019-73872	8/20/2020	1,650,000	\$245.02	9.01%	Received	9/1/2020
			259,579,735				226,294,163				
			75								
<b>Unsettled</b>											
Tax Year 2019	040-239-001-0020	Smith Jim R	2,175,000		2018-59994						
Tax Year 2019	078-051-001-0007	Grace Business Investments LLC	5,227,400		2018-69515						
Tax Year 2019	104-827-000-0001	Grace Business Investments LLC	1,772,210		2018-69515						
Tax Year 2019	040-239-001-0038	Smith Jim R	752,750		2019-53611						
Tax Year 2019	034-203-002-0101	Macey Family Properties Ltd	3,440,230		2019-54101						
Tax Year 2019	034-203-002-0108	Northden Holdings Ltd	1,309,607		2019-54298						
Tax Year 2019	034-203-002-0145	Northden Holdings Ltd	334,306		2019-54298						
Tax Year 2019	096-294-000-0003	Heritage Gulf Coast LLC	12,575		2019-55847						

**Hobby Area District  
Lawsuit and Arbitration Status Detail as of 8/7/2020**

Jur 943

Tax Year	CAD Account No.	Owner Name	ARB Hearing Value	Assessment Collected	Cause Number	Date Received from HCAD	Settled Value	Reduction in Assessment	% Reduction in Assessment	Date Designation Form Sent to Owner	Date Refund Notice Sent to Bkpr
Tax Year 2019	070-072-028-0001	Triangle Shopping Center LP	1,850,000		2019-56586						
Tax Year 2019	057-259-000-0046	Autozone Texas LP	1,246,093		2019-56953						
Tax Year 2019	040-239-000-0052	Lam Airport LP	1,900,000		2019-60193						
Tax Year 2019	128-049-001-0001	Alameda Center 45 LP	6,657,162		2019-60600						
Tax Year 2019	034-203-003-0204	Hazari LLC	740,269		2019-60849						
Tax Year 2019	034-203-003-0315	Hazari LLC	3,004,849		2019-60849						
Tax Year 2019	078-051-001-0001	PCL Galveston Partners Ltd	4,745,000		2019-62649						
Tax Year 2019	040-239-000-0078	GHC Property LLC	8,651,271		2019-62728						
Tax Year 2019	041-012-001-0032	ZMS & Associates Inc	28,400		2019-63818						
Tax Year 2019	064-063-008-0001	Furmanite US GSG LLC	1,311,500		2019-63941						
Tax Year 2019	015-115-011-0008	Adelaide Holdings LLC	1,885,186		2019-64438						
Tax Year 2019	096-319-000-0004	Icon Owner Pool 6 West Southwest	5,514,000		2019-64951						
Tax Year 2019	094-210-000-0006	Public Storage Mgmt Inc	5,561,510		2019-65624						
Tax Year 2019	094-210-000-0007	Public Storage Mgmt Inc	2,438,490		2019-65624						
Tax Year 2019	043-228-000-0041	Ean Holdings LLC	1,126,080		2019-65933						
Tax Year 2019	034-203-001-0023	Silk Road Properties LLC	383,250		2019-66899						
Tax Year 2019	034-203-001-0025	Silk Road Properties LLC	425,178		2019-66899						
Tax Year 2019	065-050-005-0004	Bradley Harry E Estate	806,136		2019-67944						
Tax Year 2019	062-031-002-0011	Maraldo Mike	762,685		2019-68070						
Tax Year 2019	098-435-000-0001	DDC Hotels Inc	7,208,682		2019-68415						
Tax Year 2019	060-077-009-0004	CWD Interests LLC	1,765,111		2019-69959						
Tax Year 2019	040-239-000-0041	ML Real Estate Interest Inc	2,499,525		2019-70058						
Tax Year 2019	040-239-001-0014	Bellfort Village Phase II	10,579,588		2019-70367						
Tax Year 2019	125-821-001-0001	ARCP MT Houston TX LLC	271,847		2019-70586						
Tax Year 2019	126-063-001-0005	ARCP MT Houston TX LLC	15,058,758		2019-70586						
Tax Year 2019	126-063-001-0006	ARCP MT Houston TX LLC	17,741,100		2019-70586						
Tax Year 2019	126-063-001-0010	ARCP MT Houston TX LLC	1,446,342		2019-70586						
Tax Year 2019	126-063-001-0011	ARCP MT Houston TX LLC	149,759		2019-70586						
Tax Year 2019	118-422-001-0006	Enterprise Leasing Company of Houston	883,387		2019-71077						
Tax Year 2019	096-249-000-0001	HSR Bellfort Plaza Apt LLC	6,050,150		2019-71443						
Tax Year 2019	034-207-012-0030	E J Stanton LP	805,708		2019-71745						
Tax Year 2019	034-203-001-0062	Sexton Interest IV Ltd	556,925		2019-72241						
Tax Year 2019	034-203-002-0100	Sexton Interests Ltd	2,824,371		2019-72527						
Tax Year 2019	034-203-003-0127	MPT Interest LLC	1,196,808		2019-72742						
Tax Year 2019	124-659-001-0002	Freeland Holdings Ltd	802,019		2019-73255						
Tax Year 2019	040-239-001-0009	Cardenas Adans	1,977,141		2019-73614						
Tax Year 2019	118-275-001-0001	Maankee Hospitality LLC	3,525,781		2019-73691						
Tax Year 2019	040-239-000-0011	Broadway Bellfort Prop LLC	2,904,568		2019-73789						
Tax Year 2019	096-318-000-0006	Snyder Dan	2,834,688		2019-73966						
Tax Year 2019	034-203-002-0105	Krishna Hobby LLC	691,408		2019-79390						
Tax Year 2019	040-239-000-0061	APTBC LLC	6,302,752		2019-82303						
Tax Year 2019	040-239-000-0073	APTWP Ltd	4,510,678		2019-82323						
Tax Year 2019	129-096-001-0006	9333 Bryant LLC	5,265,073		2019-82859						
<b>Tax Year 2019</b>	<b>Total</b>	<b>Unsettled Accounts, original value</b>	<b>161,913,306</b>								
<b>Tax Year 2019</b>	<b>Total</b>	<b>Unsettled Accounts, number of accounts</b>	<b>51</b>								

**Hobby Area District  
Lawsuit and Arbitration Status Detail as of 8/7/2020**

Jur 943

Tax Year	CAD Account No.	Owner Name	ARB Hearing Value	Assessment Collected	Cause Number	Date Received from HCAD	Settled Value	Reduction in Assessment	% Reduction in Assessment	Date Designation Form Sent to Owner	Date Refund Notice Sent to Bkpr
<b>Tax Year 2020</b>											
<b>Settled</b>											
Tax Year 2020			0				0				
			0								
<b>Unsettled</b>											
Tax Year 2020											
<b>Tax Year 2020</b>	<b>Total</b>	<b>Unsettled Accounts, original value</b>	<b>0</b>								
<b>Tax Year 2020</b>	<b>Total</b>	<b>Unsettled Accounts, number of accounts</b>	<b>0</b>								
<b>Cumulative</b>											
<b>Settled</b>											
<b>Cumulative</b>	<b>Grand Total</b>	<b>Settled Accounts, original value</b>	<b>2,778,273,427</b>				<b>2,413,353,597</b>				
<b>Cumulative</b>	<b>Grand Total</b>	<b>Settled Accounts, number of accounts</b>	<b>858</b>								
<b>Unsettled</b>											
<b>Cumulative</b>	<b>Grand Total</b>	<b>Unsettled Accounts, original value</b>	<b>220,089,338</b>								
<b>Cumulative</b>	<b>Grand Total</b>	<b>Unsettled Accounts, number of accounts</b>	<b>80</b>								
<b>Color Legend</b>											
	Light Gray	Settled previously									
	Yellow	Settled as of this report									
	White	Unsettled									
	Pink	Unsettled and new since previous report									
<b>Abbreviations</b>											
	NA	Not applicable									
	x	Previous to implementation of Designation Form									
	DELQ	Refund was not issued -- Reduction in assessment was applied to the account, and account still has a balance due.									
	PAID	Refund was not issued -- Reduction in assessment was applied to the account, and account is now paid in full.									
	NYB	Not yet billed									
	25.25b	Settled under Tax Code 25.25b; refund processed									

**Hobby Area District  
Lawsuit and Arbitration Status Summary as of 8/7/2020**

Jur 943

Summary

Settled

2,778,273,427	Original value of <b>Settled</b> accounts as of 8/7/2020
858	Number of <b>Settled</b> accounts as of 8/7/2020
364,919,830	Reduction in value of <b>Settled</b> accounts
<b>13.13%</b>	Average % reduction in value of <b>Settled</b> accounts

Unsettled

220,089,338	Original value of <b>Unsettled</b> accounts as of 8/7/2020
80	Number of <b>Unsettled</b> accounts as of 8/7/2020

0.15 Tax rate per \$100 valuation

<b>\$43,362</b>	Estimated* reduction in assessment on	80	Unsettled accounts,
	based on	<b>13.13%</b>	average

*Historical data from Tax Years 2007 through 2012 were used to establish initial statistics for the "average % reduction in value of Settled accounts."*





## HOBBY AREA DISTRICT

(HARRIS COUNTY IMPROVEMENT DISTRICT NO. 9)  
CITY OF HOUSTON  
HARRIS COUNTY, TEXAS

---

---

### AGENDA MEMORANDUM

---

---

To: Hobby Area District Board of Directors  
From: Executive Director  
Subject: Agenda Item Materials

---

6. Discuss Clark Condon's updated cost estimate relating to the underpass project



**HOBBY AREA DISTRICT  
GATEWAYS**

**HOBBY AREA MANAGEMENT DISTRICT  
CLARK CONDON**  
09.28.2020

HISTORICAL IMAGERY





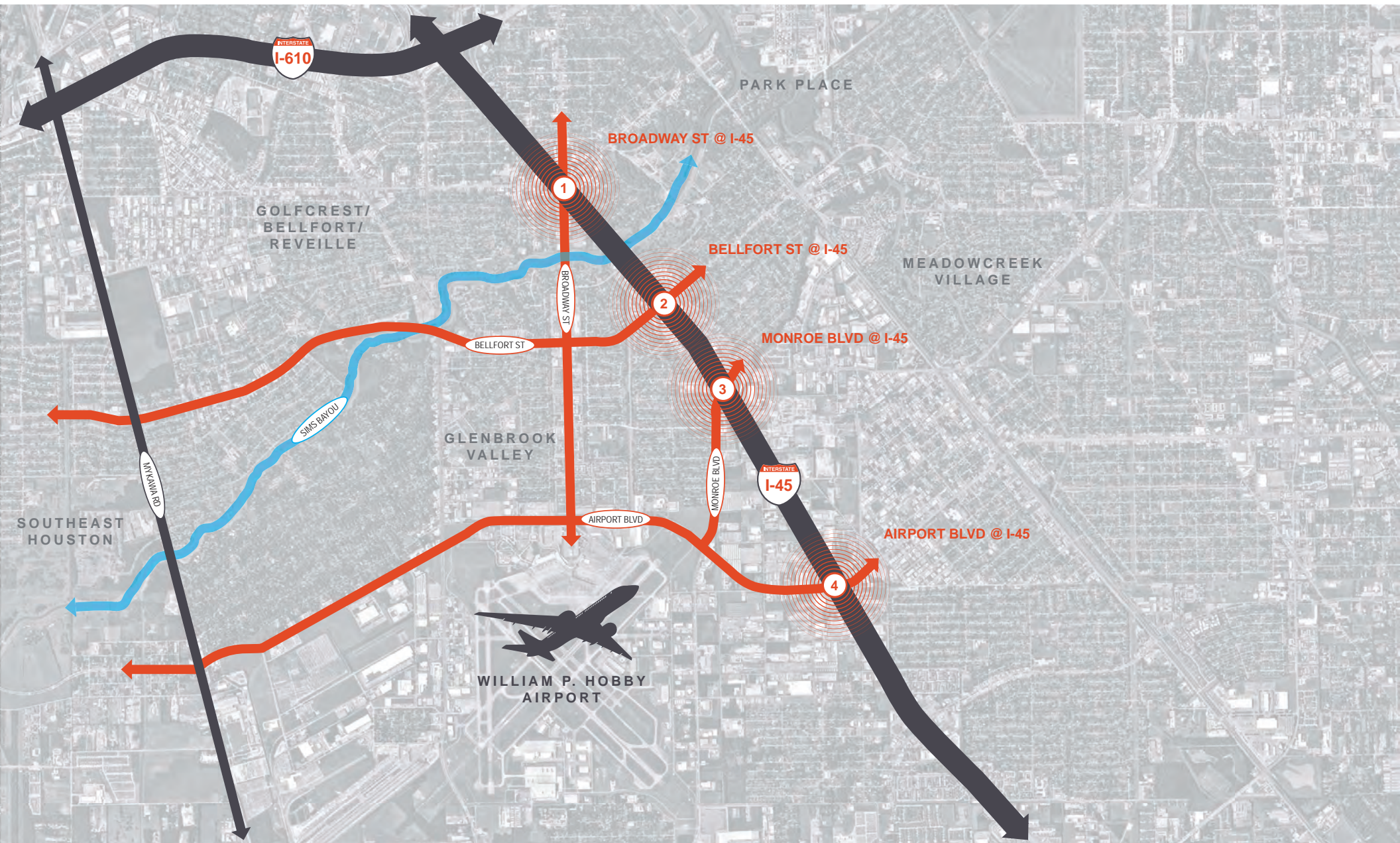



AIRPORT BLVD @ I-45





**VISIBILITY**

IDENTIFY ENTRY CIRCULATION PATTERNS TO DETERMINE OPPORTUNITIES FOR ART AND MONUMENTATION



**IDENTITY + LEGIBILITY**

IDENTIFY POTENTIAL MONUMENT AND SIGNAGE LOCATIONS FOR GATEWAY



**IDENTIFY POTENTIAL OPPORTUNITIES**

IS THERE ADJACENT LAND THAT CAN BE UTILIZED AND ENHANCED?





**VISIBILITY**  
 IDENTIFY ENTRY CIRCULATION PATTERNS TO DETERMINE OPPORTUNITIES FOR ART AND MONUMENTATION



**ILLUMINATION**  
 PROVIDE CONSISTENT UNDERBRIDGE LIGHTING



**CURB APPEAL**  
 PROVIDE NEW AND MODERN PAVING ALONG RIGHT OF WAY. POWERWASH WEATHERED SURFACES.



**COLOR AND CONTRAST**  
 REDUCE HARDSCAPE SURFACES BY INTEGRATING MORE SOFTSCAPE AREAS AT EDGES OF OVERPASS



**IDENTITY + LEGIBILITY**  
 IDENTIFY POTENTIAL MONUMENT AND SIGNAGE LOCATIONS FOR GATEWAY



**IDENTIFY POTENTIAL OPPORTUNITIES**  
 IS THERE ADJACENT LAND THAT CAN BE UTILIZED AND ENHANCED?





EXISTING CONDITONS







**LEGEND**







**IDENTITY**

-  MONUMENT - FREEWAY
-  MONUMENT - NEIGHBORHOOD
-  ART COLUMN ACCENTS
-  IDENTITY FENCE

**SAFETY**

-  UNDERPASS LIGHTING
-  CROSSWALK IDENTIFICATION

**CURB APPEAL**

-  STREET TREES
-  ORNAMENTAL TREES
-  FORMAL PALM TREES
-  COLORFUL GROUNDCOVER
-  LAWN
-  PAVER HARDSCAPE
-  CONCRETE PAVING

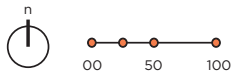

THIS DRAWING IS CONCEPTUAL IN NATURE AND IS SUBJECT TO CHANGE. NO WARRANTIES OR REPRESENTATIONS, EXPRESSED OR IMPLIED CONCERNING THE ACTUAL DESIGN, LOCATION OR CHARACTER OF THIS PLAN ARE INTENDED. THIS PLAN IS NOT FOR PERMIT OR CONSTRUCTION PURPOSES.

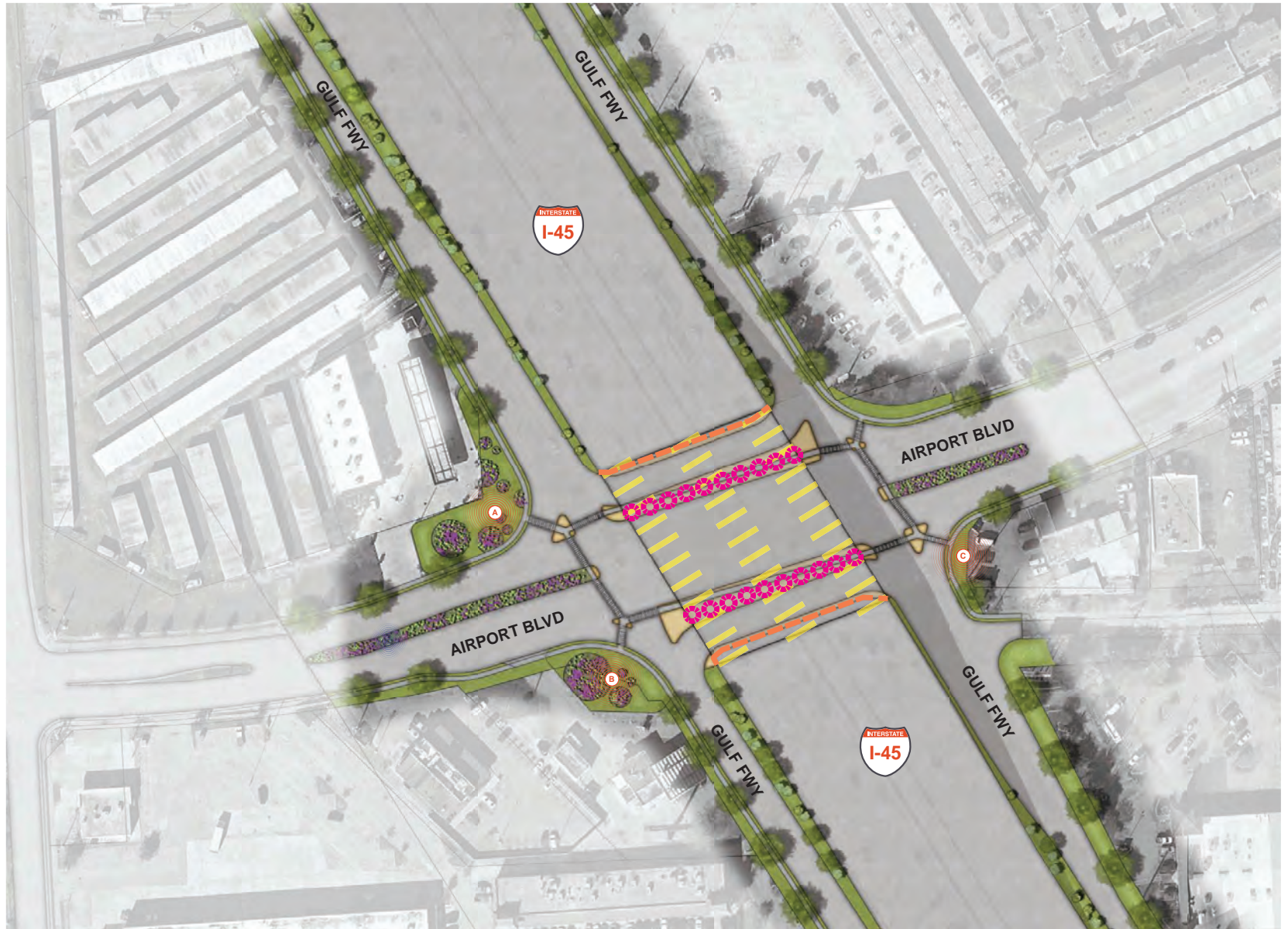



MONROE BLVD @ I-45

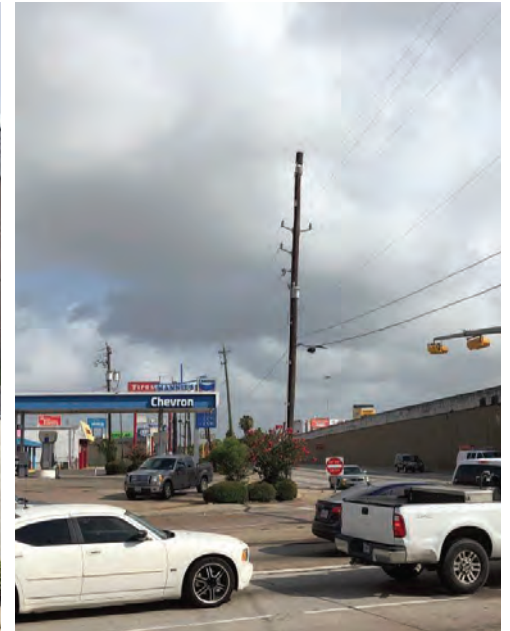



**VISIBILITY**  
 IDENTIFY ENTRY CIRCULATION PATTERNS TO DETERMINE OPPORTUNITIES FOR ART AND MONUMENTATION



**ILLUMINATION**  
 PROVIDE CONSISTENT UNDERBRIDGE LIGHTING



**CURB APPEAL**  
 PROVIDE NEW AND MODERN PAVING ALONG RIGHT OF WAY. POWERWASH WEATHERED SURFACES.



**COLOR AND CONTRAST**  
 REDUCE HARDSCAPE SURFACES BY INTEGRATING MORE SOFTSCAPE AREAS AT EDGES OF OVERPASS



**IDENTITY + LEGIBILITY**  
 IDENTIFY POTENTIAL MONUMENT AND SIGNAGE LOCATIONS FOR GATEWAY



**IDENTIFY POTENTIAL OPPORTUNITIES**  
 IS THERE ADJACENT LAND THAT CAN BE UTILIZED AND ENHANCED?





EXISTING CONDITONS







**LEGEND**







**IDENTITY**

-  MONUMENT - FREEWAY
-  MONUMENT - NEIGHBORHOOD
-  ART COLUMN ACCENTS
-  IDENTITY FENCE

**SAFETY**

-  UNDERPASS LIGHTING
-  CROSSWALK IDENTIFICATION

**CURB APPEAL**

-  STREET TREES
-  ORNAMENTAL TREES
-  FORMAL PALM TREES
-  COLORFUL GROUNDCOVER
-  LAWN
-  PAVER HARDSCAPE
-  CONCRETE PAVING

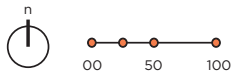

THIS DRAWING IS CONCEPTUAL IN NATURE AND IS SUBJECT TO CHANGE. NO WARRANTIES OR REPRESENTATIONS, EXPRESSED OR IMPLIED CONCERNING THE ACTUAL DESIGN, LOCATION OR CHARACTER OF THIS PLAN ARE INTENDED. THIS PLAN IS NOT FOR PERMIT OR CONSTRUCTION PURPOSES.

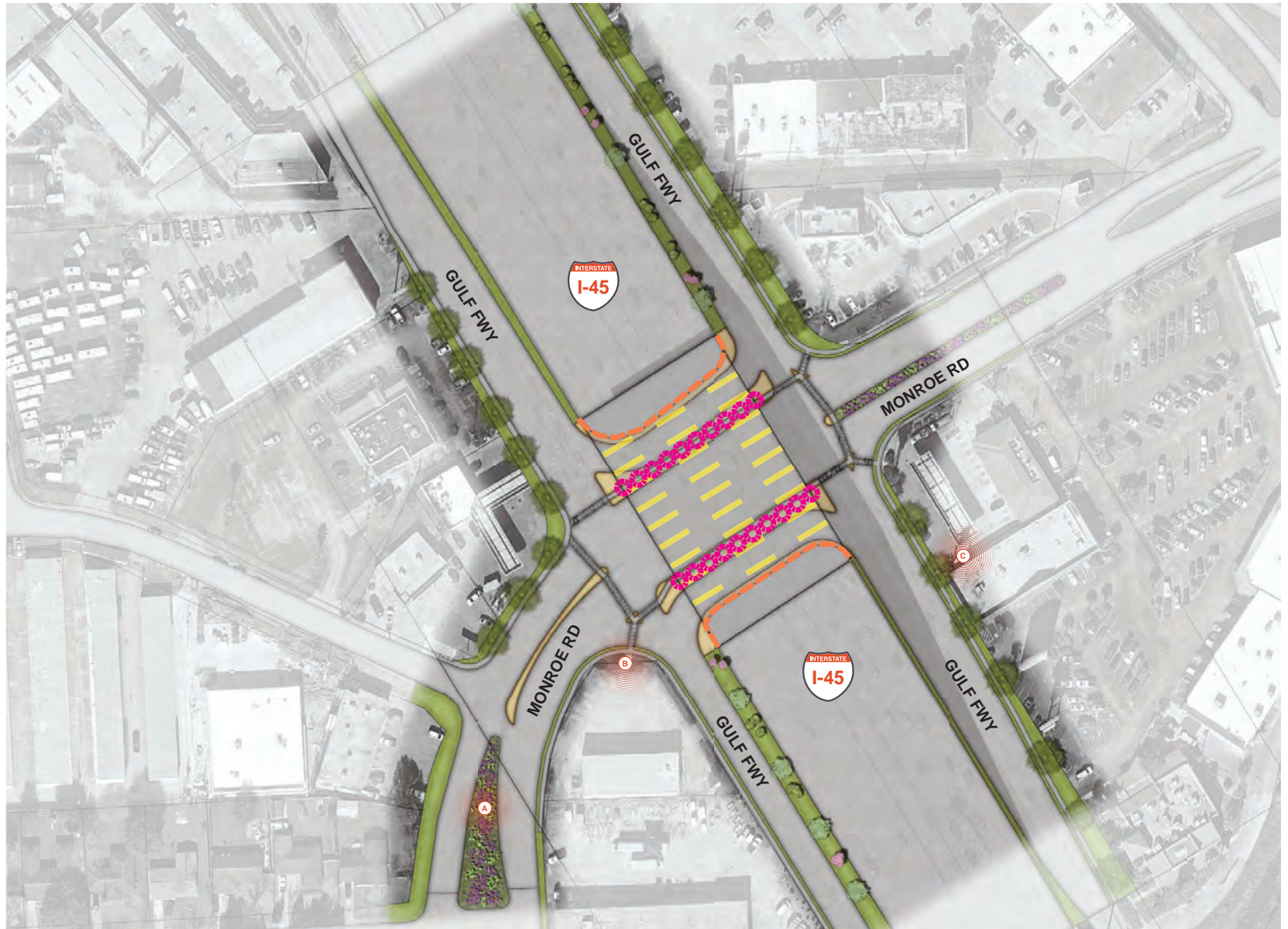

**BELLFORT ST @ I-45**





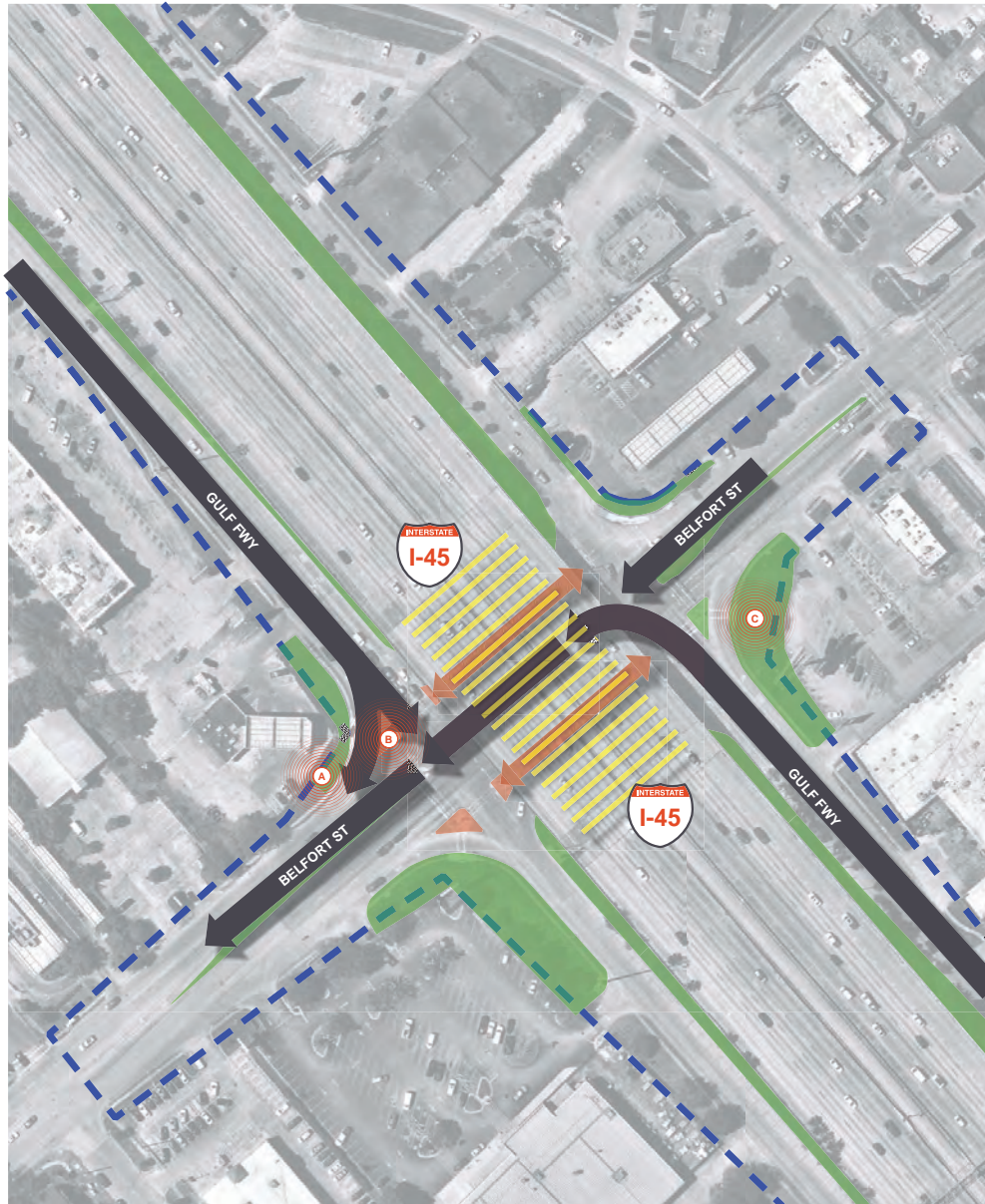

**VISIBILITY**  
 IDENTIFY ENTRY CIRCULATION PATTERNS TO DETERMINE OPPORTUNITIES FOR ART AND MONUMENTATION



**ILLUMINATION**  
 PROVIDE CONSISTENT UNDERBRIDGE LIGHTING



**CURB APPEAL**  
 PROVIDE NEW AND MODERN PAVING ALONG RIGHT OF WAY. POWERWASH WEATHERED SURFACES.



**COLOR AND CONTRAST**  
 REDUCE HARDSCAPE SURFACES BY INTEGRATING MORE SOFTSCAPE AREAS AT EDGES OF OVERPASS



**IDENTITY + LEGIBILITY**  
 IDENTIFY POTENTIAL MONUMENT AND SIGNAGE LOCATIONS FOR GATEWAY



**IDENTIFY POTENTIAL OPPORTUNITIES**  
 IS THERE ADJACENT LAND THAT CAN BE UTILIZED AND ENHANCED?



**TXDOT RIGHT OF WAY**





EXISTING CONDITIONS







**LEGEND**







**IDENTITY**

-  MONUMENT - FREEWAY
-  MONUMENT - NEIGHBORHOOD
-  ART COLUMN ACCENTS
-  IDENTITY FENCE

**SAFETY**

-  UNDERPASS LIGHTING
-  CROSSWALK IDENTIFICATION

**CURB APPEAL**

-  STREET TREES
-  ORNAMENTAL TREES
-  FORMAL PALM TREES
-  COLORFUL GROUNDCOVER
-  LAWN
-  PAVER HARDSCAPE
-  CONCRETE PAVING

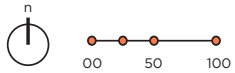

THIS DRAWING IS CONCEPTUAL IN NATURE AND IS SUBJECT TO CHANGE. NO WARRANTIES OR REPRESENTATIONS, EXPRESSED OR IMPLIED CONCERNING THE ACTUAL DESIGN, LOCATION OR CHARACTER OF THIS PLAN ARE INTENDED. THIS PLAN IS NOT FOR PERMIT OR CONSTRUCTION PURPOSES.

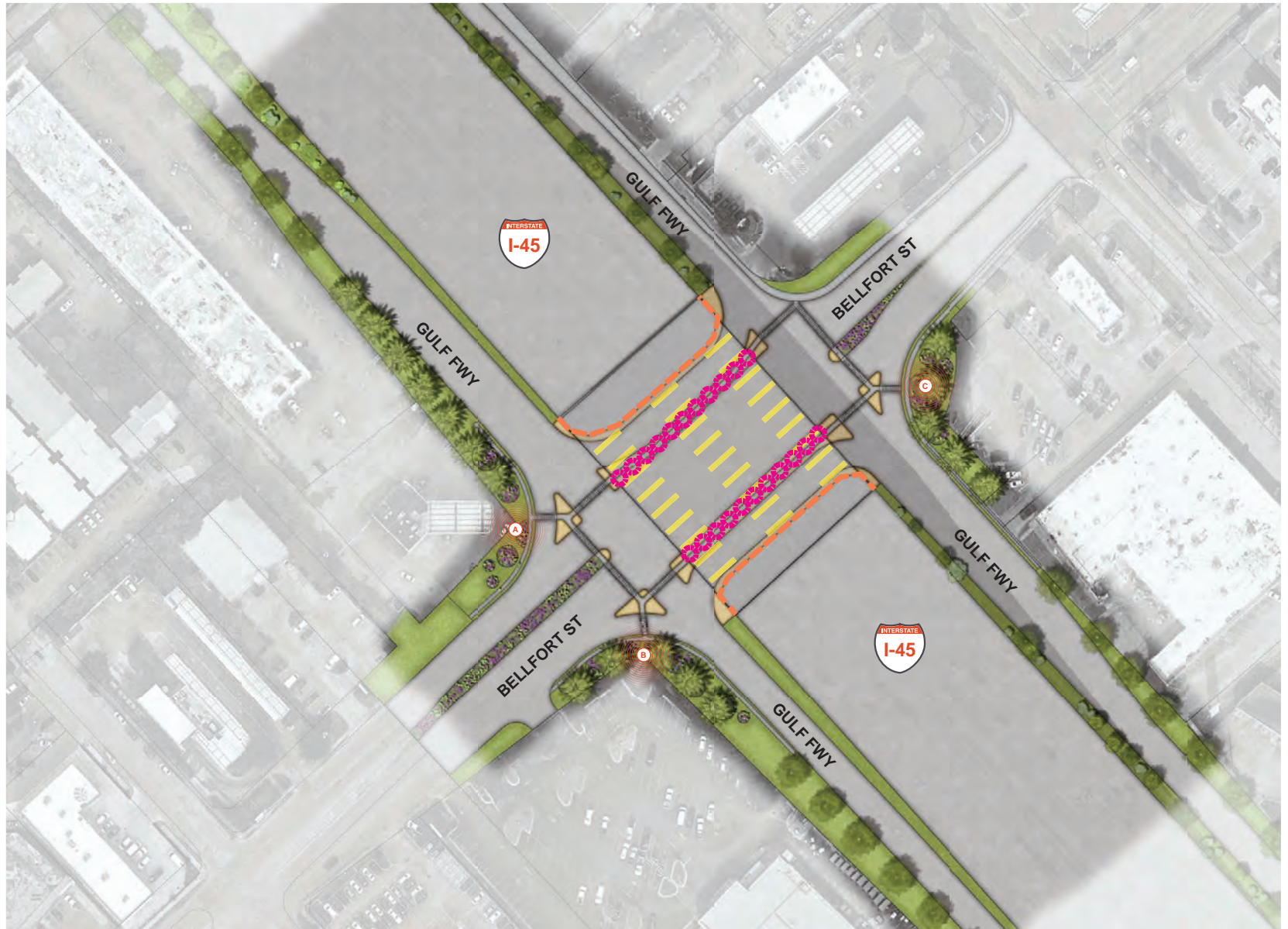



**BROADWAY ST @ I-45**







**VISIBILITY**

IDENTIFY ENTRY CIRCULATION PATTERNS TO DETERMINE OPPORTUNITIES FOR ART AND MONUMENTATION



**ILLUMINATION**

PROVIDE CONSISTENT UNDERBRIDGE LIGHTING



**CURB APPEAL**

PROVIDE NEW AND MODERN PAVING ALONG RIGHT OF WAY. POWERWASH WEATHERED SURFACES.



**COLOR AND CONTRAST**

REDUCE HARDSCAPE SURFACES BY INTEGRATING MORE SOFTSCAPE AREAS AT EDGES OF OVERPASS



**IDENTITY + LEGIBILITY**

IDENTIFY POTENTIAL MONUMENT AND SIGNAGE LOCATIONS FOR GATEWAY



**IDENTIFY POTENTIAL OPPORTUNITIES**

IS THERE ADJACENT LAND THAT CAN BE UTILIZED AND ENHANCED?



**TXDOT RIGHT OF WAY**

EXISTING CONDITONS





LIGHTING, CURB APPEAL + ART





LIGHTING

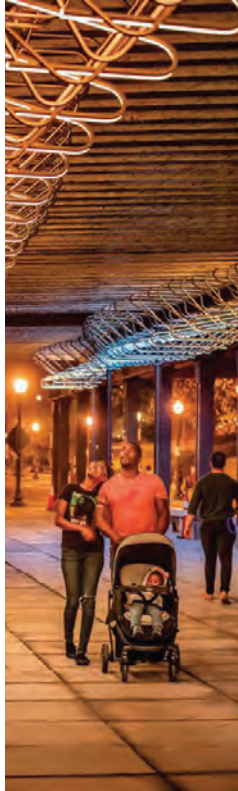

BARRIERS



SURFACING

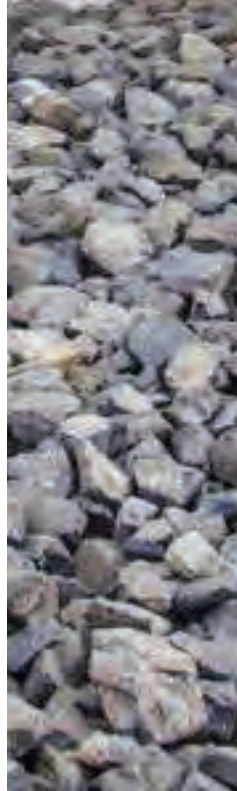

GROUND COVER



ART

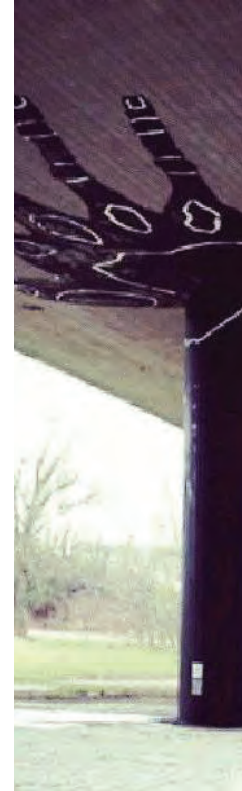



PAVING







**LEGEND**

**IDENTITY**







-  MONUMENT - FREEWAY
-  MONUMENT - NEIGHBORHOOD
-  ART COLUMN ACCENTS

**IDENTITY FENCE**

**SAFETY**

-  UNDERPASS LIGHTING
-  CROSSWALK IDENTIFICATION

**CURB APPEAL**

-  STREET TREES
-  ORNAMENTAL TREES
-  FORMAL PALM TREES
-  COLORFUL GROUNDCOVER
-  LAWN
-  PAVER HARDSCAPE
-  CONCRETE PAVING

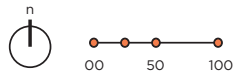

THIS DRAWING IS CONCEPTUAL IN NATURE AND IS SUBJECT TO CHANGE. NO WARRANTIES OR REPRESENTATIONS, EXPRESSED OR IMPLIED CONCERNING THE ACTUAL DESIGN, LOCATION OR CHARACTER OF THIS PLAN ARE INTENDED. THIS PLAN IS NOT FOR PERMIT OR CONSTRUCTION PURPOSES.













LARGE SCALE ENTRY MONUMENTS

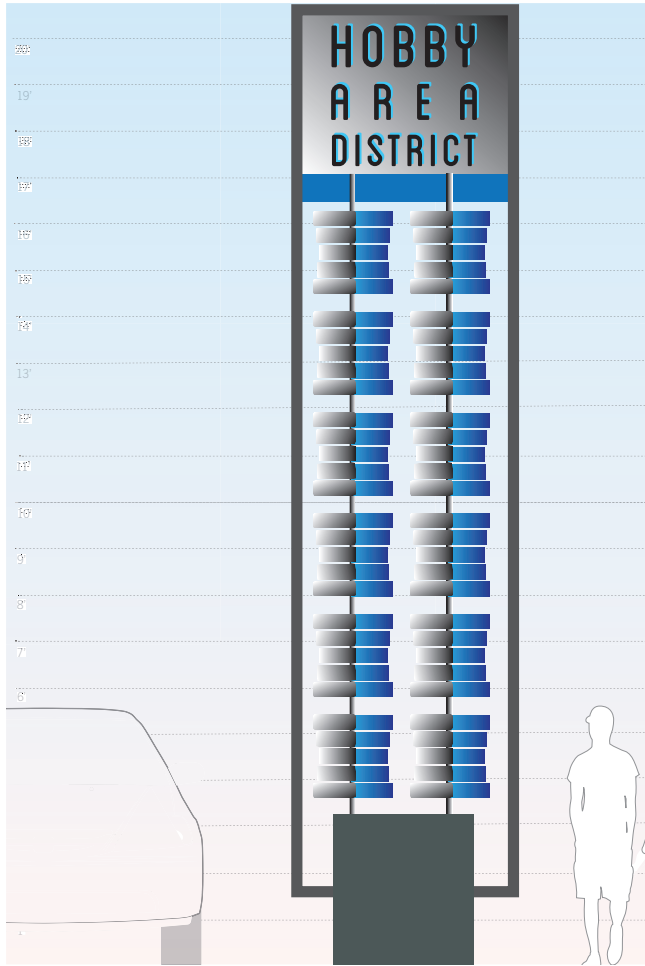

OPTION A

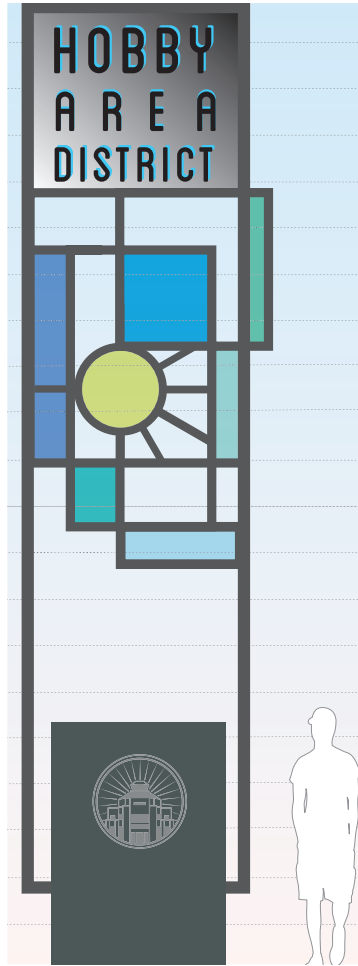

OPTION B

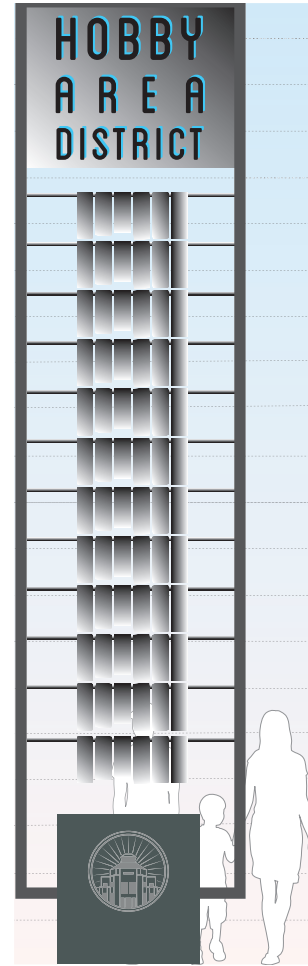

OPTION C

ID MARKERS

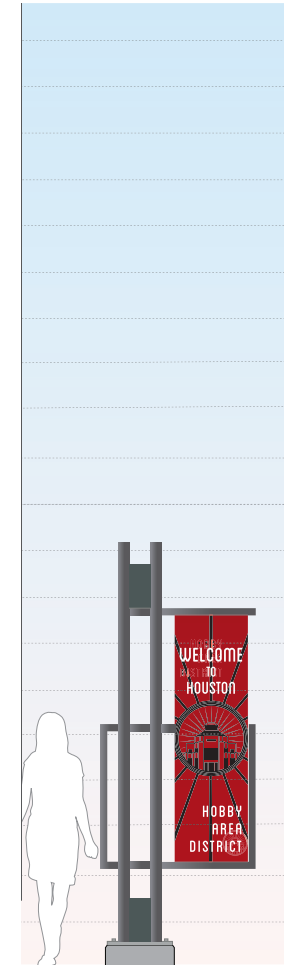

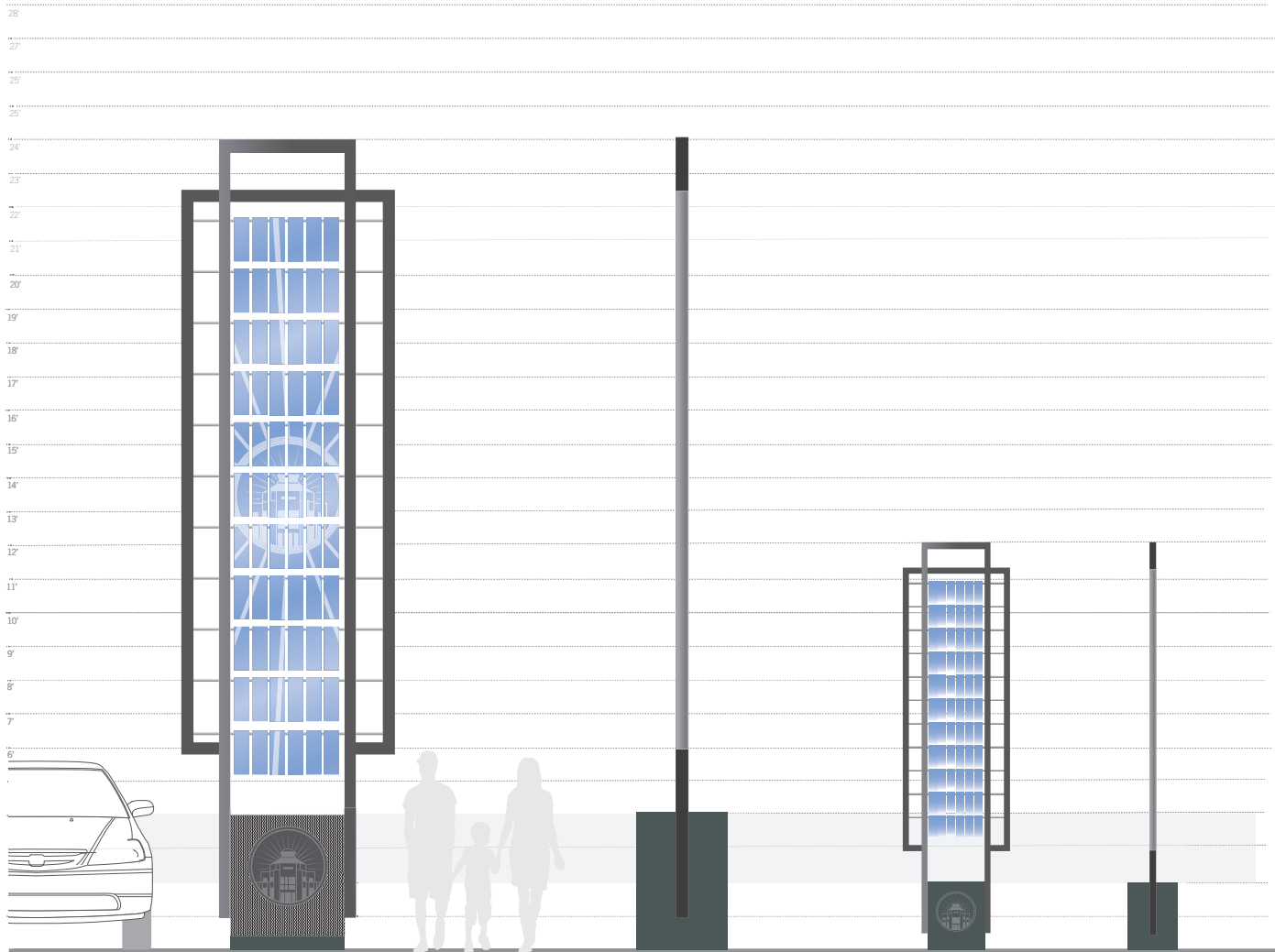

Kinetic Identity Marker

24' height

12' height

- Features
- Pivoted wind blown fins - Direct Embed panels with logo graphic
  - Steel structure - painted
  - Illumination - Uplight from base - double sided

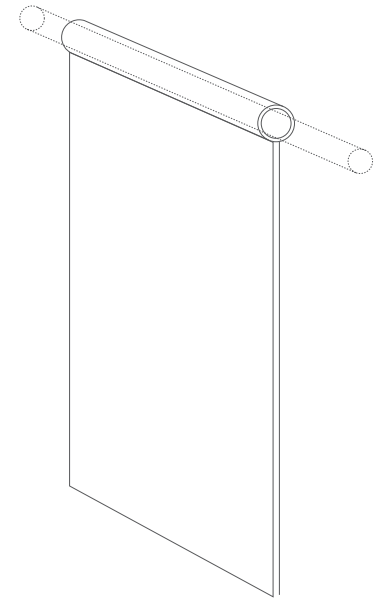

KENETIC PANELS

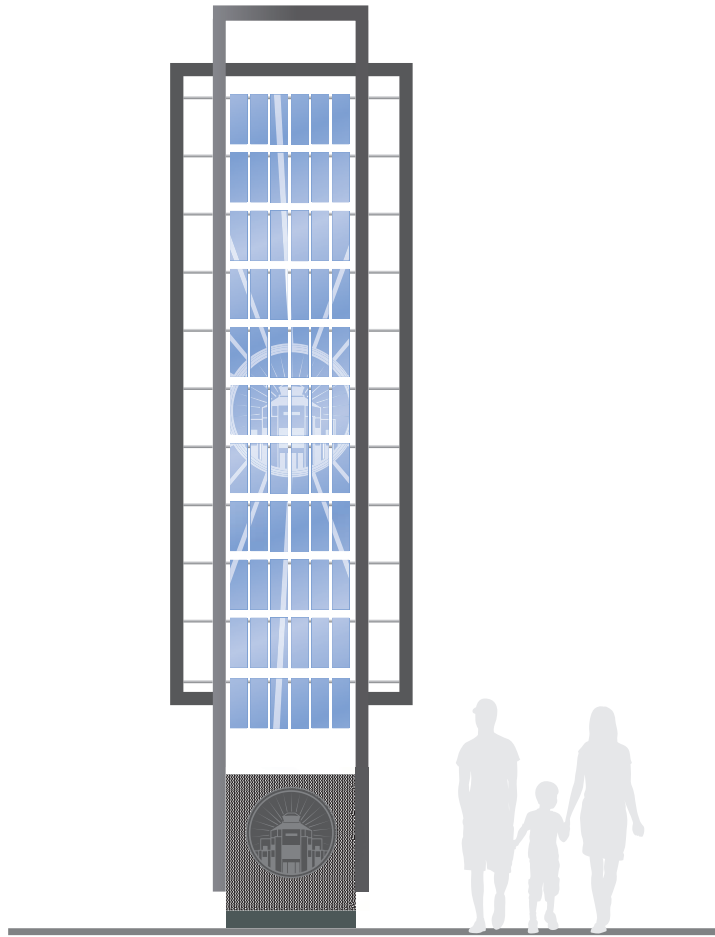

DISTRICT LOGO



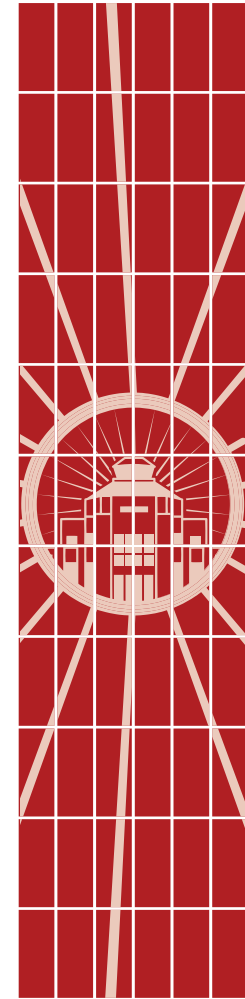
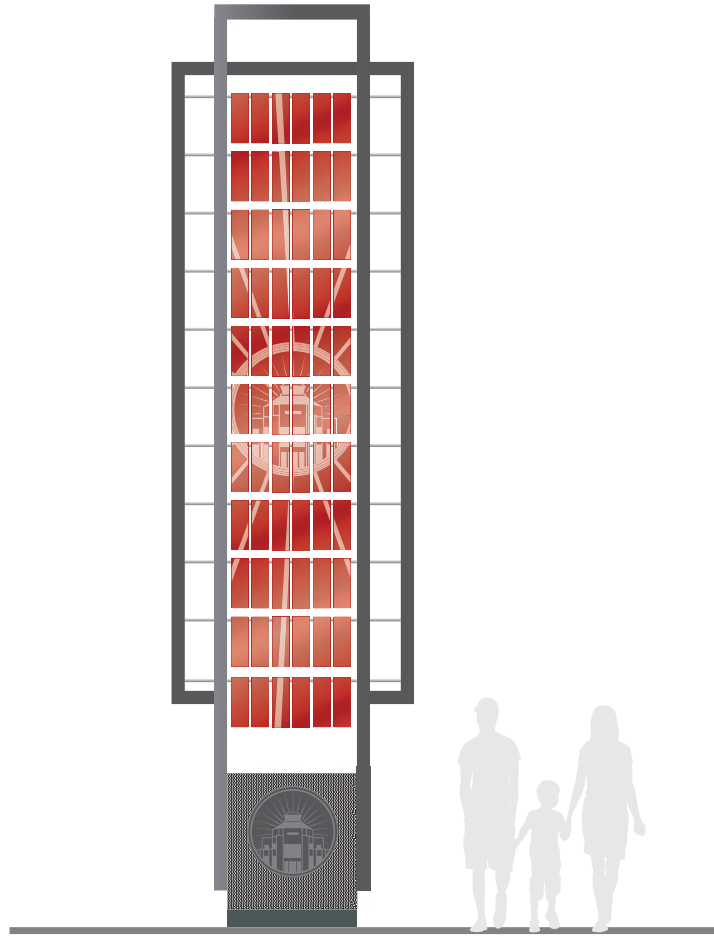

DISTRICT LOGO

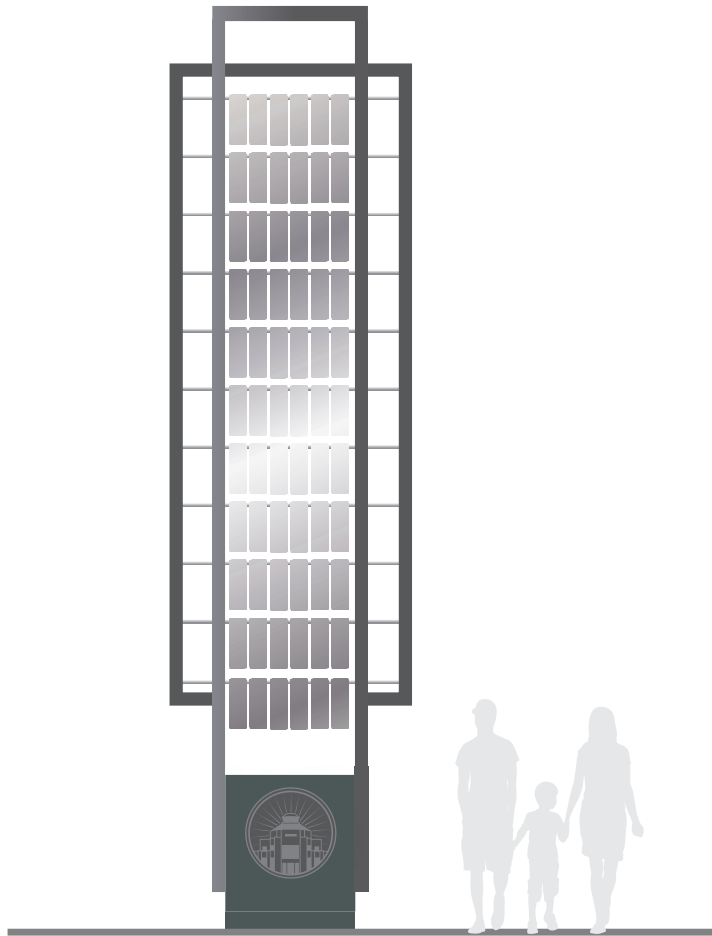
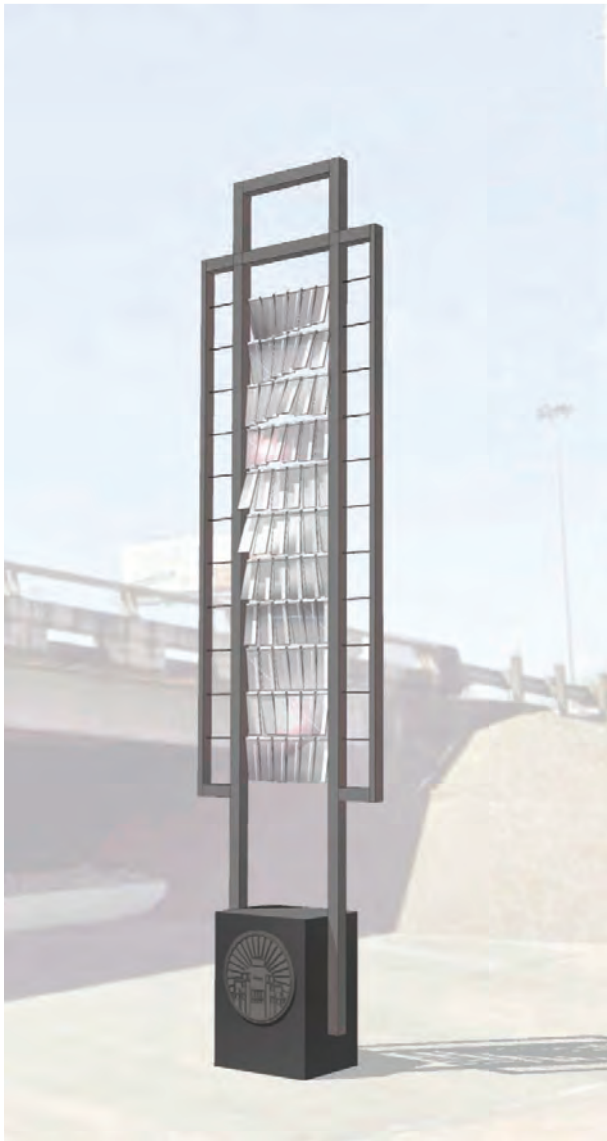

Polished Metal

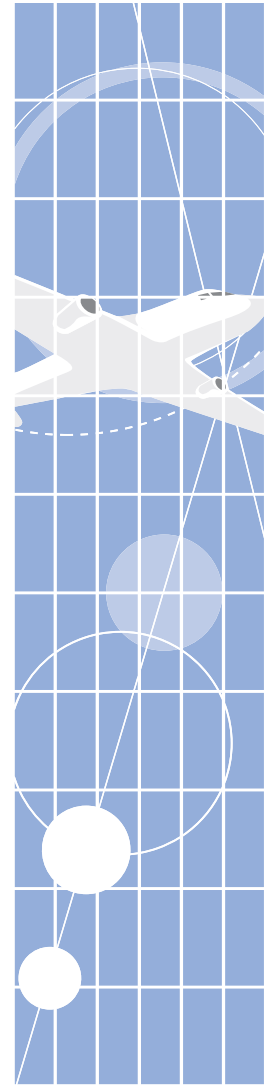
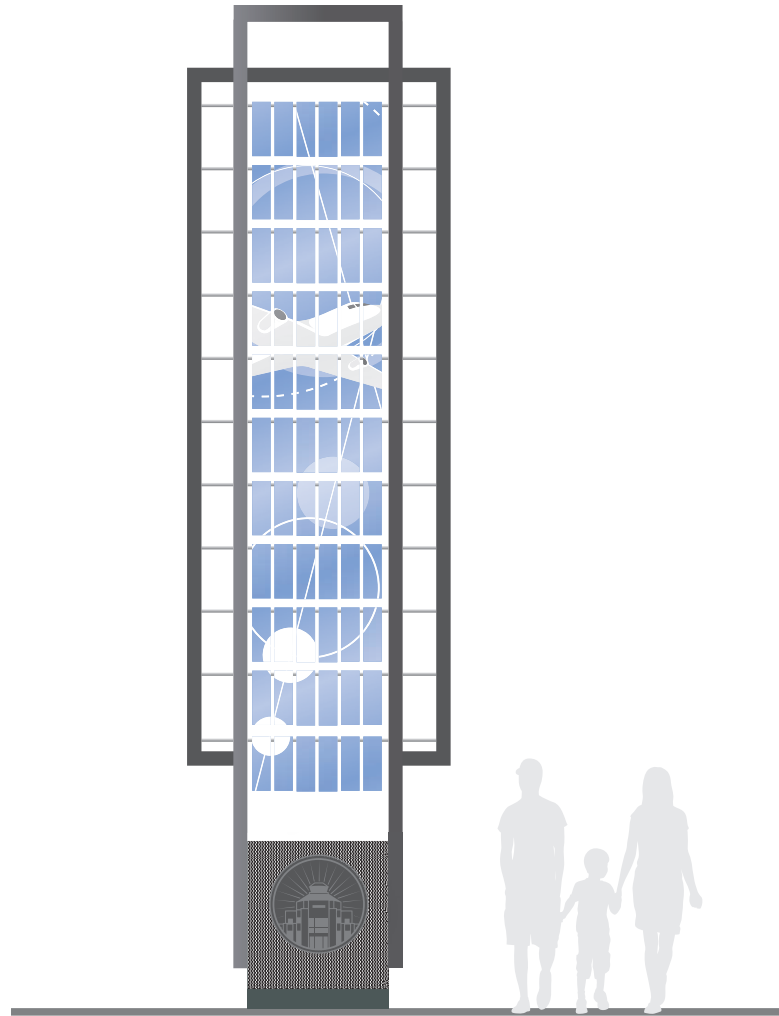
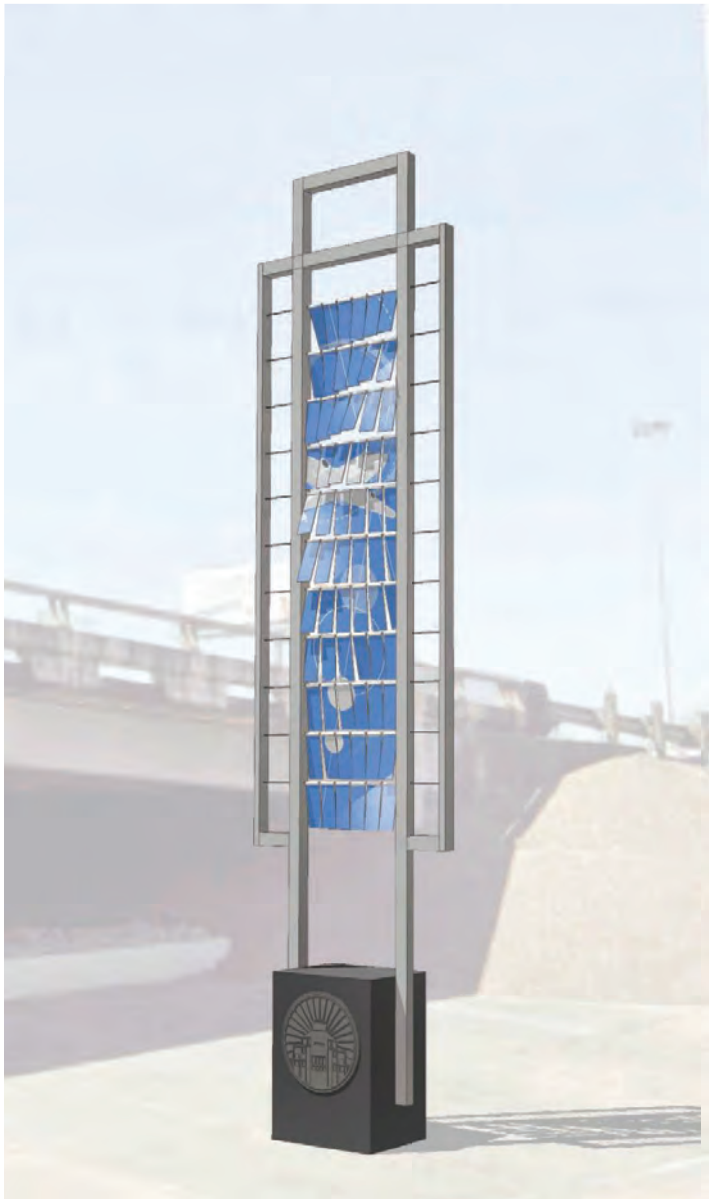

GRAPHICS



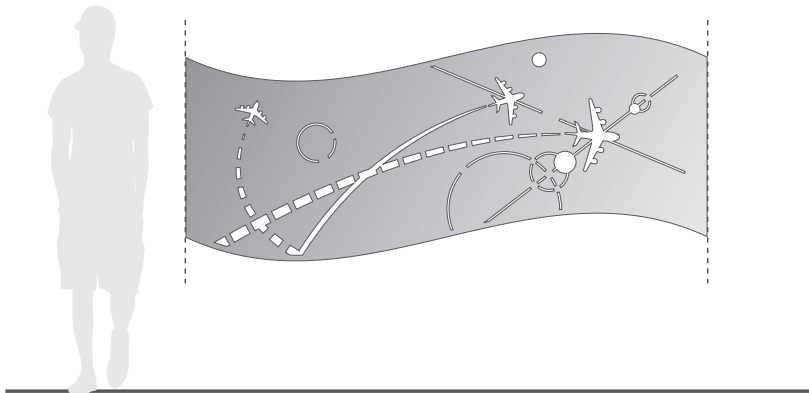
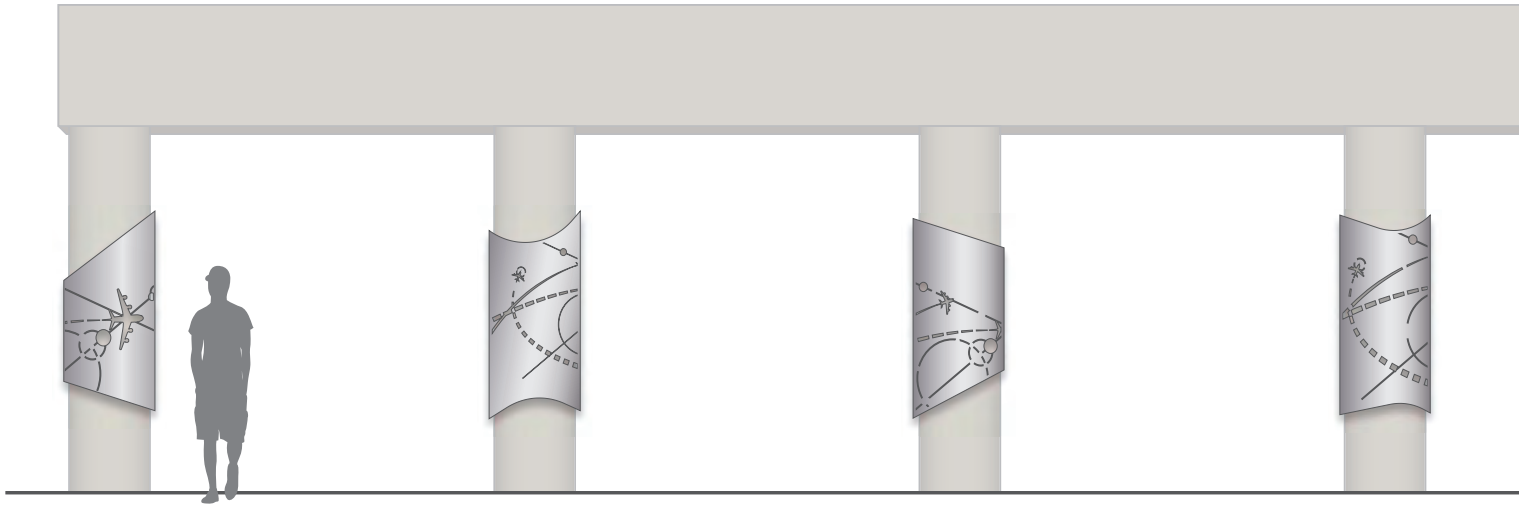

Waterjet Cut Metal Panel Wrap



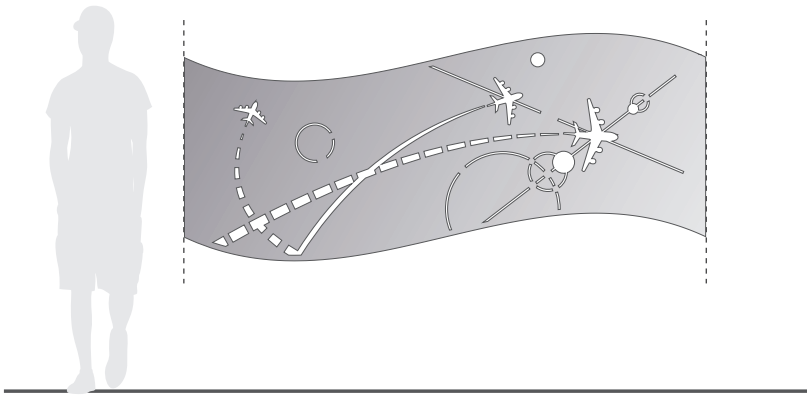
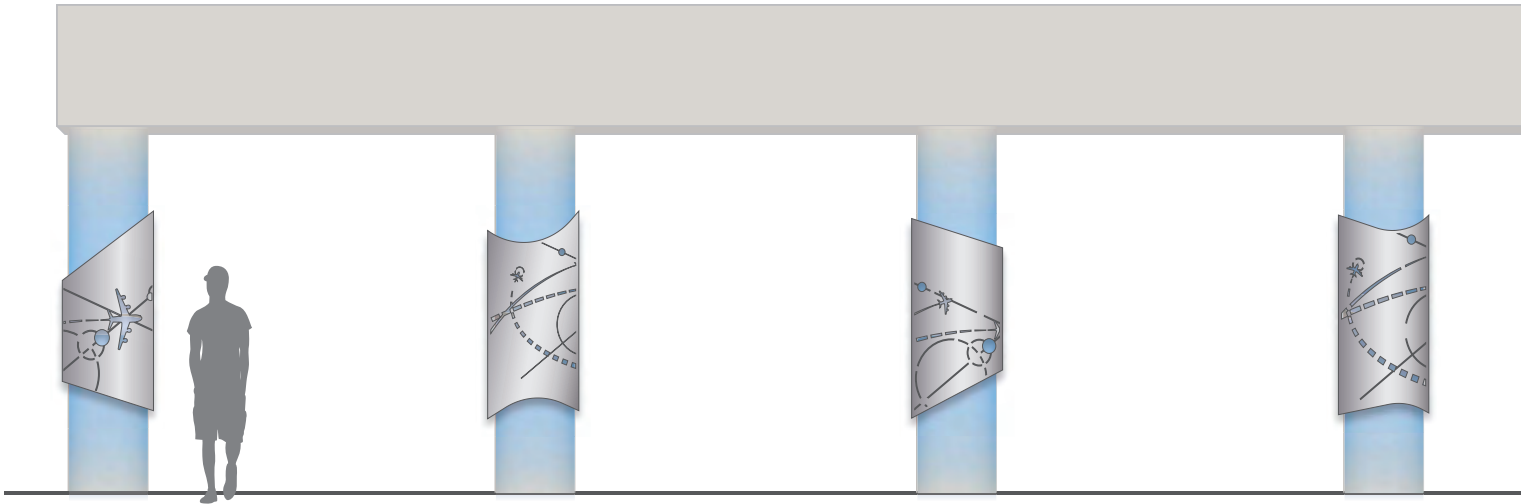

Waterjet Cut Metal Panel Wrap  
Light wash on overpass column



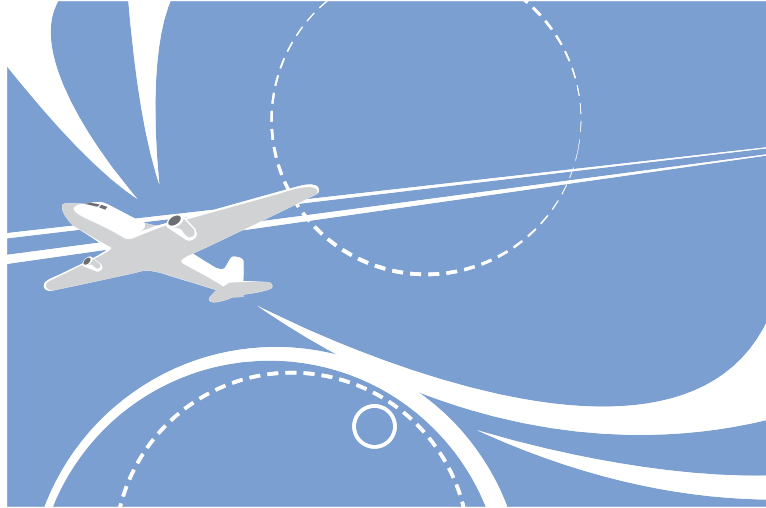
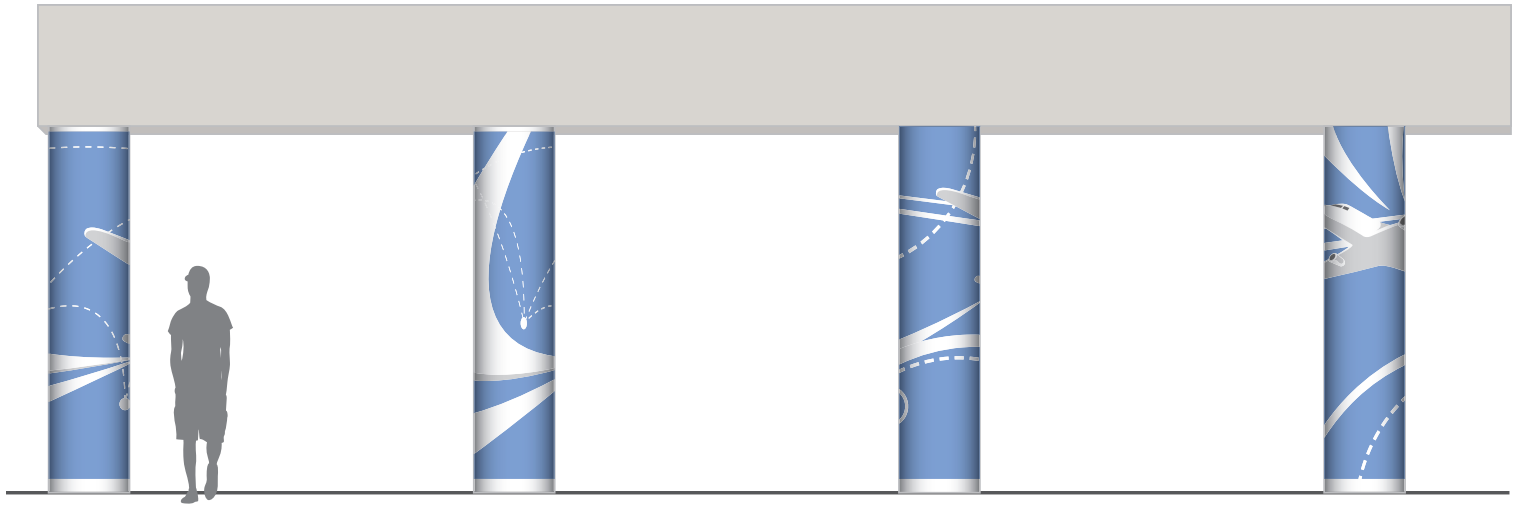

Aeronautic Graphic Wrap





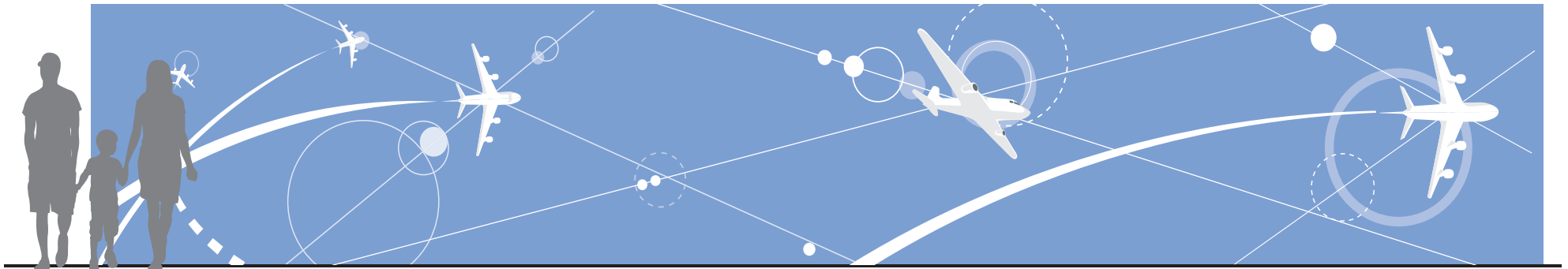

Printed Graphic mesh fence covering



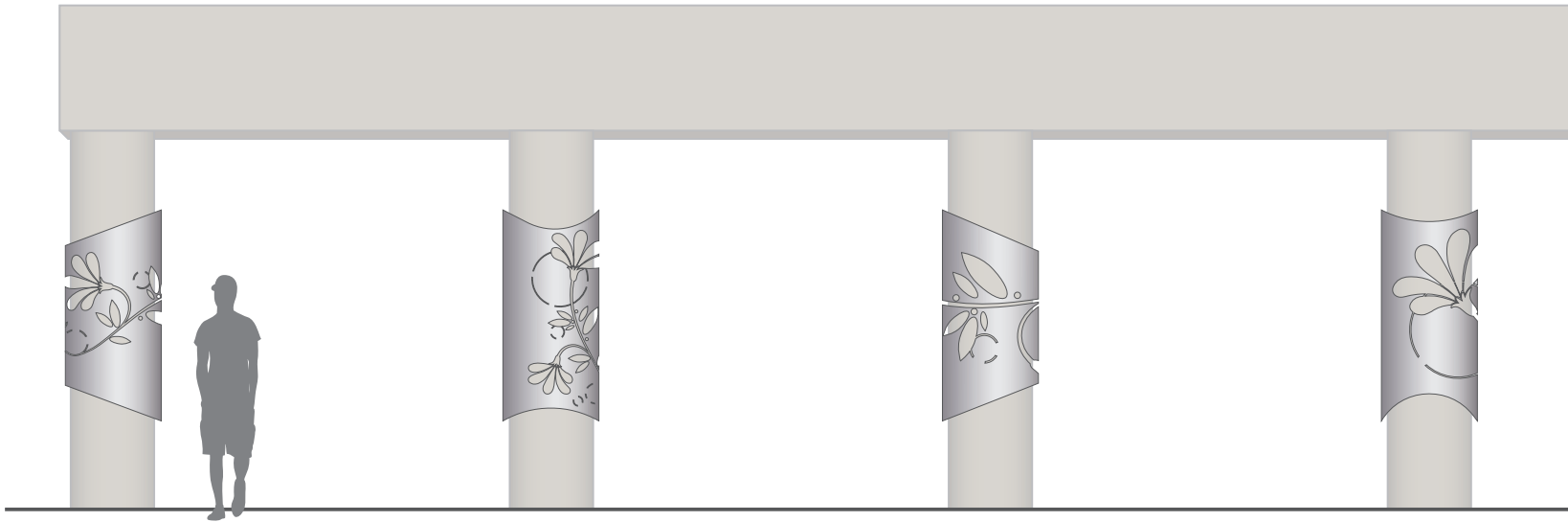

Waterjet Cut Metal Panel Wrap





Waterjet Cut Metal Panel Wrap







Botanical Graphic Wrap

**HOBBY DISTRICT GATEWAYS** | **PAINTED COLUMN ACCENTS**  
 HOBBY AREA MANAGEMENT DISTRICT | 09.28.2020  
 120-090





Printed Graphic mesh fence covering

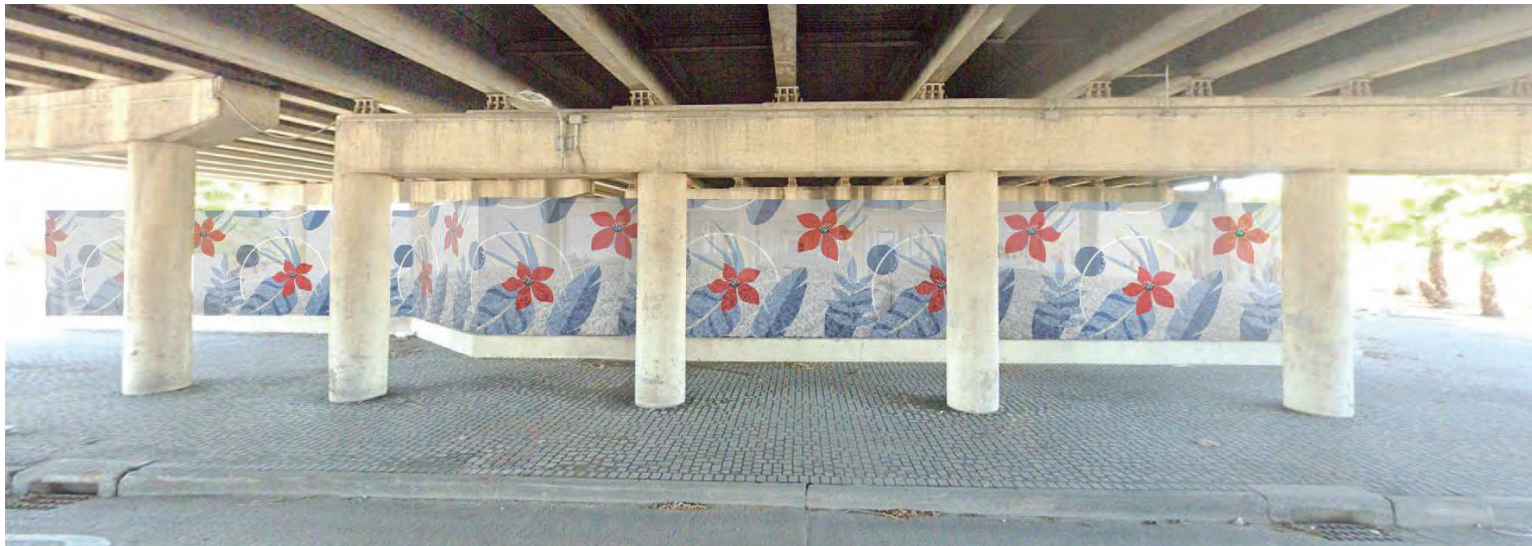

Hobby Area Gateways  
Preliminary Cost Estimate

CLARK CONDON

30-Sep-20

Item					
<u>No.</u>	<u>Item</u>	<u>Qty.</u>	<u>Unit</u>	<u>Cost</u>	<u>Extension</u>
<b>Phase 1 - Power Washing, Painting &amp; Screening</b>					
<u>General</u>					
1	Site Prep & Mobilization	1	LS	\$46,500.00	\$46,500.00
2	Bonds	1	LS	\$86,500.00	\$86,500.00
3	Permitting	1	LS	\$3,500.00	\$3,500.00
4	SWPPP & Traffic Control	1	LS	\$105,000.00	<u>\$105,000.00</u>
				<b>Total General</b>	<b>\$241,500.00</b>
<u>I-45 @ Broadway St.</u>					
<u>Demolition</u>					
5.	Hardscape Demolition	25,000	SF	\$2.00	<u>\$50,000.00</u>
				<b>Total Demolition</b>	<b>\$50,000.00</b>
<u>Hardscape</u>					
8.	Power washing Overpass, Abutments & Columns	125,000	SFF	\$1.00	\$125,000.00
9.	Paint Overpass, Abutments & Columns	125,000	SFF	\$2.00	\$250,000.00
11.	Decorative Overpass Screening	15,000	SFF	\$60.00	\$900,000.00
14.	Misc. Hardscape Repairs	1	LS	\$10,000.00	<u>\$10,000.00</u>
				<b>Total Hardscape</b>	<b>\$1,285,000.00</b>



Item

<u>No.</u>	<u>Item</u>	<u>Qty.</u>	<u>Unit</u>	<u>Cost</u>	<u>Extension</u>
<u>I-45 @ Belfort St.</u>					
<u>Demolition</u>					
5	Hardscape Demolition	10,000	SF	\$2.00	<u>\$20,000.00</u>
				<b>Total Demolition</b>	<b>\$20,000.00</b>
<u>Hardscape</u>					
8	Power washing Overpass, Abutments & Columns	86,000	SFF	\$1.00	\$86,000.00
9	Paint Overpass, Abutments & Columns	86,000	SFF	\$2.00	\$172,000.00
11	Decorative Overpass Screening	6,500	SFF	\$60.00	\$390,000.00
14	Misc. Hardscape Repairs	1	LS	\$10,000.00	<u>\$10,000.00</u>
				<b>Total Hardscape</b>	<b>\$658,000.00</b>

Item

<u>No.</u>	<u>Item</u>	<u>Qty.</u>	<u>Unit</u>	<u>Cost</u>	<u>Extension</u>
<u>I-45 @ Monroe Blvd.</u>					
<u>Demolition</u>					
5	Hardscape Demolition	10,000	SF	\$2.00	<u>\$20,000.00</u>
<b>Total Demolition</b>					<b>\$20,000.00</b>
<u>Hardscape</u>					
8	Power washing Overpass, Abutments & Columns	81,000	SFF	\$1.00	\$81,000.00
9	Paint Overpass, Abutments & Columns	81,000	SFF	\$2.00	\$162,000.00
11	Decorative Overpass Screening	5,500	SFF	\$60.00	\$330,000.00
14	Misc. Hardscape Repairs	1	LS	\$10,000.00	<u>\$10,000.00</u>
<b>Total Hardscape</b>					<b>\$583,000.00</b>

Item					
<u>No.</u>	<u>Item</u>	<u>Qty.</u>	<u>Unit</u>	<u>Cost</u>	<u>Extension</u>
	<u>I-45 @ Airport Blvd.</u>				
	<u>Demolition</u>				
5	Hardscape Demolition	10,000	SF	\$2.00	<u>\$20,000.00</u>
				<b>Total Demolition</b>	<b>\$20,000.00</b>
	<u>Hardscape</u>				
8	Power washing Overpass, Abutments & Columns	115,000	SFF	\$1.00	\$115,000.00
9	Paint Overpass, Abutments & Columns	115,000	SFF	\$2.00	\$230,000.00
11	Decorative Overpass Screening	5,300	SFF	\$60.00	\$318,000.00
14	Misc. Hardscape Repairs	1	LS	\$10,000.00	<u>\$10,000.00</u>
				<b>Total Hardscape</b>	<b>\$673,000.00</b>
				<b>Subtotal Phase 1</b>	<b>\$3,550,500.00</b>
				15% Contingency	\$532,575.00
				<u>Soft Costs</u>	<u>\$355,050.00</u>
				<b>Total Phase 1</b>	<b>\$4,438,125.00</b>



Item					
<u>No.</u>	<u>Item</u>	<u>Qty.</u>	<u>Unit</u>	<u>Cost</u>	<u>Extension</u>
<b>Phase 2 - Hardscape &amp; Lighting</b>					
<u>General</u>					
1	Site Prep & Mobilization	1	LS	\$46,500.00	\$46,500.00
2	Bonds	1	LS	\$86,500.00	\$86,500.00
3	Permitting	1	LS	\$3,500.00	\$3,500.00
4	SWPPP & Traffic Control	1	LS	\$105,000.00	<u>\$105,000.00</u>
				<b>Total General</b>	<b>\$241,500.00</b>
<u>I-45 @ Broadway St.</u>					
<u>Demolition</u>					
5.	Hardscape Demolition	75,000	SF	\$2.00	\$150,000.00
6.	Softscape Demolition	1	LS	\$20,000.00	<u>\$20,000.00</u>
				<b>Total Demolition</b>	<b>\$170,000.00</b>
<u>Grading &amp; Drainage</u>					
7.	Grading, Earthwork, and Drainage	1	LS	\$60,000.00	<u>\$60,000.00</u>
				<b>Total Grading and Drainage</b>	<b>\$60,000.00</b>
<u>Hardscape</u>					
10.	Concrete Pavers	53,000	SF	\$12.50	\$662,500.00
12.	Monument Signs	2	EA	\$125,000.00	\$250,000.00
13.	Decorative Column Wraps	400	SFF	\$50.00	\$20,000.00
14.	Misc. Hardscape Repairs	1	LS	\$15,000.00	<u>\$15,000.00</u>
				<b>Total Hardscape</b>	<b>\$947,500.00</b>
<u>Lighting and Electrical</u>					
15.	Electrical Service & Controls	1	LS	\$25,000.00	\$25,000.00
16.	Architectural Lighting	1	LS	\$75,000.00	<u>\$75,000.00</u>
				<b>Total Lighting and Electrical</b>	<b>\$100,000.00</b>

Item					
<u>No.</u>	<u>Item</u>	<u>Qty.</u>	<u>Unit</u>	<u>Cost</u>	<u>Extension</u>
<u>I-45 @ Belfort St.</u>					
<u>Demolition</u>					
5	Hardscape Demolition	19,000	SF	\$2.00	\$38,000.00
6	Softscape Demolition	1	LS	\$5,000.00	<u>\$5,000.00</u>
<b>Total Demolition</b>					<b>\$43,000.00</b>
<u>Grading &amp; Drainage</u>					
7	Grading, Earthwork, and Drainage	1	LS	\$10,000.00	<u>\$10,000.00</u>
<b>Total Grading and Drainage</b>					<b>\$10,000.00</b>
<u>Hardscape</u>					
10	Concrete Pavers	19,200	SF	\$12.50	\$240,000.00
12	Monument Signs	2	EA	\$100,000.00	\$200,000.00
13	Decorative Column Wraps	1,300	SFF	\$50.00	\$65,000.00
14	Misc. Hardscape Repairs	1	LS	\$15,000.00	<u>\$15,000.00</u>
<b>Total Hardscape</b>					<b>\$520,000.00</b>
<u>Lighting and Electrical</u>					
15	Electrical Service & Controls	1	LS	\$25,000.00	\$25,000.00
16	Architectural Lighting	1	LS	\$75,000.00	<u>\$75,000.00</u>
<b>Total Lighting and Electrical</b>					<b>\$100,000.00</b>

Item					
<u>No.</u>	<u>Item</u>	<u>Qty.</u>	<u>Unit</u>	<u>Cost</u>	<u>Extension</u>
<u>I-45 @ Monroe Blvd.</u>					
<u>Demolition</u>					
5	Hardscape Demolition	22,000	SF	\$2.00	\$44,000.00
6	Softscape Demolition	1	LS	\$5,000.00	<u>\$5,000.00</u>
				<b>Total Demolition</b>	<b>\$49,000.00</b>
<u>Grading &amp; Drainage</u>					
7	Grading, Earthwork, and Drainage	1	LS	\$10,000.00	<u>\$10,000.00</u>
				<b>Total Grading and Drainage</b>	<b>\$10,000.00</b>
<u>Hardscape</u>					
10	Concrete Pavers	29,650	SF	\$12.50	\$370,625.00
12	Monument Signs	1	EA	\$100,000.00	\$100,000.00
13	Decorative Column Wraps	1,200	SFF	\$50.00	\$60,000.00
14	Misc. Hardscape Repairs	1	LS	\$15,000.00	<u>\$15,000.00</u>
				<b>Total Hardscape</b>	<b>\$545,625.00</b>
<u>Lighting and Electrical</u>					
15	Electrical Service & Controls	1	LS	\$25,000.00	\$25,000.00
16	Architectural Lighting	1	LS	\$75,000.00	<u>\$75,000.00</u>
				<b>Total Lighting and Electrical</b>	<b>\$100,000.00</b>



Item					
<u>No.</u>	<u>Item</u>	<u>Qty.</u>	<u>Unit</u>	<u>Cost</u>	<u>Extension</u>
<b>I-45 @ Airport Blvd.</b>					
<u>Demolition</u>					
5	Hardscape Demolition	18,000	SF	\$2.00	\$36,000.00
6	Softscape Demolition	1	LS	\$5,000.00	<u>\$5,000.00</u>
<b>Total Demolition</b>					<b>\$41,000.00</b>
<u>Grading &amp; Drainage</u>					
7	Grading, Earthwork, and Drainage	1	LS	\$10,000.00	<u>\$10,000.00</u>
<b>Total Grading and Drainage</b>					<b>\$10,000.00</b>
<u>Hardscape</u>					
10	Concrete Pavers	17,600	SF	\$12.50	\$220,000.00
12	Monument Signs	2	EA	\$100,000.00	\$200,000.00
13	Decorative Column Wraps	1,000	SFF	\$50.00	\$50,000.00
14	Misc. Hardscape Repairs	1	LS	\$15,000.00	<u>\$15,000.00</u>
<b>Total Hardscape</b>					<b>\$485,000.00</b>
<u>Lighting and Electrical</u>					
15	Electrical Service	1	LS	\$25,000.00	\$25,000.00
16	Architectural Lighting	1	LS	\$75,000.00	<u>\$75,000.00</u>
<b>Total Lighting and Electrical</b>					<b>\$100,000.00</b>
<b>Subtotal Phase 2</b>					<b>\$3,532,625.00</b>
15% Contingency					\$529,893.75
<u>Soft Costs</u>					<u>\$353,262.50</u>
<b>Total Phase 2</b>					<b>\$4,415,781.25</b>

## Item

<u>No.</u>	<u>Item</u>	<u>Qty.</u>	<u>Unit</u>	<u>Cost</u>	<u>Extension</u>
<b>Phase 3 - Softscape</b>					
<u>General</u>					
1	Site Prep & Mobilization	1	LS	\$46,500.00	\$46,500.00
2	Bonds	1	LS	\$86,500.00	\$86,500.00
3	Permitting	1	LS	\$3,500.00	\$3,500.00
4	SWPPP & Traffic Control	1	LS	\$105,000.00	<u>\$105,000.00</u>
				<b>Total General</b>	<b>\$241,500.00</b>
<u>I-45 @ Broadway St.</u>					
<u>Softscape</u>					
17.	Irrigation System	1	LS	\$120,000.00	\$120,000.00
18.	Shrubs & Groundcover	50,000	SF	\$6.00	\$300,000.00
19.	Fine Grade & Sod	38,000	SF	\$0.35	\$13,300.00
20.	Ornamental Trees	20	EA	\$250.00	\$5,000.00
21.	Palm Trees	34	EA	\$2,500.00	\$85,000.00
22.	Street Trees	60	EA	\$650.00	\$39,000.00
23.	90 Day Landscape Maintenance	1	LS	\$8,500.00	<u>\$8,500.00</u>
				<b>Total Softscape</b>	<b>\$570,800.00</b>

Item

<u>No.</u>	<u>Item</u>	<u>Qty.</u>	<u>Unit</u>	<u>Cost</u>	<u>Extension</u>
<u>I-45 @ Belfort St.</u>					
<u>Softscape</u>					
17	Irrigation System	1	LS	\$120,000.00	\$120,000.00
18	Shrubs & Groundcover	30,000	SF	\$6.00	\$180,000.00
19	Fine Grade & Sod	20,000	SF	\$0.35	\$7,000.00
20	Ornamental Trees	20	EA	\$250.00	\$5,000.00
21	Palm Trees	16	EA	\$2,500.00	\$40,000.00
22	Street Trees	40	EA	\$650.00	\$26,000.00
23	90 Day Landscape Maintenance	1	LS	\$6,000.00	<u>\$6,000.00</u>
<b>Total Softscape</b>					<b>\$384,000.00</b>



Item

<u>No.</u>	<u>Item</u>	<u>Qty.</u>	<u>Unit</u>	<u>Cost</u>	<u>Extension</u>
<u>I-45 @ Monroe Blvd.</u>					
<u>Softscape</u>					
17	Irrigation System	1	LS	\$120,000.00	\$120,000.00
18	Shrubs & Groundcover	22,500	SF	\$6.00	\$135,000.00
19	Fine Grade & Sod	2,500	SF	\$0.35	\$875.00
20	Ornamental Trees	10	EA	\$250.00	\$2,500.00
21	Palm Trees	16	EA	\$2,500.00	\$40,000.00
22	Street Trees	20	EA	\$650.00	\$13,000.00
23	90 Day Landscape Maintenance	1	LS	\$6,000.00	<u>\$6,000.00</u>
<b>Total Softscape</b>					<b>\$317,375.00</b>

Item

<u>No.</u>	<u>Item</u>	<u>Qty.</u>	<u>Unit</u>	<u>Cost</u>	<u>Extension</u>
<u>I-45 @ Airport Blvd.</u>					
17	Softscape	1	LS	\$120,000.00	\$120,000.00
18	Irrigation System	25,000	SF	\$6.00	\$150,000.00
19	Shrubs & Groundcover	2,500	SF	\$0.35	\$875.00
20	Fine Grade & Sod	10	EA	\$250.00	\$2,500.00
21	Ornamental Trees	16	EA	\$2,500.00	\$40,000.00
22	Palm Trees	20	EA	\$650.00	\$13,000.00
23	Street Trees	1	LS	\$6,000.00	<u>\$6,000.00</u>
	90 Day Landscape Maintenance			<b>Total Softscape</b>	<b>\$332,375.00</b>

Subtotal Phase 3	\$1,846,050.00
15% Contingency	\$276,907.50
<u>Soft Costs</u>	<u>\$184,605.00</u>
<b>Total Phase 3</b>	<b>\$2,307,562.50</b>

<b>TOTAL PROJECT</b>	<b>\$11,161,468.75</b>
----------------------	------------------------



HOBBY AREA DISTRICT

---

**CLARK CONDON**





## HOBBY AREA DISTRICT

(HARRIS COUNTY IMPROVEMENT DISTRICT NO. 9)  
CITY OF HOUSTON  
HARRIS COUNTY, TEXAS

---

---

### AGENDA MEMORANDUM

---

---

To: Hobby Area District Board of Directors  
From: Executive Director  
Subject: Agenda Item Materials

---

7. Approve Agreement for Supplemental Professional Services by and between Hobby Area Management District and Hawes Hill & Associates, LLP.



## HOBBY AREA DISTRICT

August 13, 2020

To: Ms Beth Strobe  
Executive Director

From: Dave Hawes  
Intergovernmental Relations

**Agenda Item 13: Discuss strategies for monitoring activities with potential impact on the District during the legislative session which convenes in January 2021.**

This January the Legislature will convene in its 87<sup>th</sup> Term. As always, we can and should expect legislation that will further limit management districts' authority and operation. Last session, the statute reduced the requirement for dissolution from 75% of value to 66% of value. It further limited dissolution petitions to property subject to assessment versus total value within the district. The latter not being an unreasonable change.

It is important that Hobby district staff work closely with the district's attorney to track any and all legislation related to special purpose districts in order to be effective in providing testimony at legislative committee hearings in person and in written format.

Hawes Hill & Associates maintains a legislative alert tracking procedure, as does ABHR. ABHR maintains an office in Austin with seasoned attorneys who deal with special district issues. At the same time, the city of Houston and Hawes Hill maintain close and daily communications during the session to coordinate and write Fiscal Notes/Position papers regarding proposed legislation concerning special district matters.

**Recommendation:**

It is recommended that the district board consider designating a District Legislative Committee. This committee should be no more than three (3) board members. In this way, the district's staff responsible for intergovernmental relations and the district's attorney have a specified group to work with during the session on legislation that affects how districts operate. This committee will be kept up to date on legislation and be on call to attend committee hearings, as necessary.

Please note three things. This session will be like no other. Leadership may change in the House. How the legislature operates may be much different in response to the COVID-19 issue. And, most importantly, the HAMD may only provide information and is prohibited by state law from lobbying.

**AGREEMENT FOR SUPPLEMENTAL PROFESSIONAL SERVICES  
BY AND BETWEEN  
HOBBY AREA DISTRICT  
AND HAWES HILL & ASSOCIATES, LLP**

This agreement is made by and between HOBBY AREA DISTRICT (the "Client") and HAWES HILL & ASSOCIATES, LLP (the "Consultant").

W I T N E S S E T H :

WHEREAS, the Client desires that the Consultant provide certain supplemental professional services related to the development, maintenance and enhancement of intergovernmental relations between and among the Client and federal, state, and local government entities and agencies, including the elected and appointed officials and staff members affiliated with them, for the purpose of advancing the District's programs, projects, and Service Plan and Assessment Plan;

WHEREAS, the Consultant has the employees, office operations, and knowledge to ably provide the professional services required by the Client;

NOW THEREFORE, Client and Consultant, in consideration of the mutual covenants and agreements herein contained and other good and valuable consideration, do agree as follows:

I.  
Services

The Consultant hereby agrees to provide, furnish, or perform certain professional services with respect to the intergovernmental relations, herein collectively referred to as the "Services."

II.  
Performance of Services

Consultant shall have the right to determine the method, details, and means of performing the Services. The Client, however, shall be entitled to ensure satisfactory performance, including the rights to inspect, to stop work, to make suggestions or recommendations as to the details of the work, and to propose modifications to the Services. Consultant will provide all required resources and personnel to complete the Services and use its best efforts to accommodate work schedule requests in a timely manner.

III.  
Compensation and Reimbursement to Consultant

For and in consideration of the professional services rendered by the Consultant as specified in agrees to pay the Consultant a fixed fee of SIXTY THOUSAND AND NO/100 DOLLARS (\$60,000.00) payable in twelve (12) monthly installments of FIVE THOUSAND AND NO/100 DOLLARS (\$5,000.00) each commencing within thirty (30) days of authorization for additional services.

Consultant shall tender to the Client a detailed invoice of the services performed and the allowable reimbursable expenses incurred to the Client each month during the term of this Agreement. Payments on account of services rendered and for reimbursable expenses incurred shall be made within thirty (30) days after the Client receives Consultant's detailed invoice therefore. In the event of a disputed or contested invoice, the Client may withhold any such disputed or contested amount without penalty.



IV.  
Right of Ownership

All data, information, maps, books, reports, files, photography, artwork, software, equipment, and materials purchased, created or maintained by the Client or purchased, created or maintained by the Consultant on behalf of the Client shall remain the property of the Client. It shall be clearly marked as property of the Client in such manner that it may at any time be removed from the premises of the Consultant.

V.  
Laws to be Observed

In performing its obligations under this Agreement, the Consultant at all times shall observe and comply with all federal and state laws, local laws, ordinances, orders, and regulations of the federal, state, county, or city governments. The federal, state, and local laws, ordinances, and regulations which affect those engaged or employed in the work, or the equipment used in the work, or which in any way affects the conduct of the work, shall be at all times in effect, and no pleas of misunderstanding will be considered on account of ignorance thereof.

VI.  
Successors and Assigns

This Agreement shall bind and benefit the respective parties and their legal successors, and shall not be assignable, in whole or in part, by any party hereto without first obtaining the written consent of the other party. Nothing herein shall be construed as creating any personal liability on the part of any officer or director of the proposed district.

VII.  
Independent Contractors

The Consultant shall be an independent contractor to the Client, and nothing in this Agreement shall be deemed to cause this Agreement to create an agency, partnership, or joint venture between the parties. This Agreement shall not be interpreted or construed as creating or establishing the relationship of employer and employee between the Client and the Consultant, or any of the Consultant's employees or agents.

VIII.  
Conflict of Interest

In keeping with Consultant's duties to the Client, Consultant agrees that it shall not, directly or indirectly, become involved in any conflict of interest, or upon discovery thereof, allow such a conflict to continue. Moreover, Consultant agrees that it shall promptly disclose to the Client any facts which might involve any reasonable possibility of a conflict of interest.

IX.  
Term and Termination

This Agreement shall become effective as of the date executed by the Client and the Consultant as set forth on the signature page hereof. Either party may terminate this Agreement at any time by giving the other party at least thirty (30) days' prior written notice thereof, specifying in such notice the effective date of such termination. In the event of termination, it is understood and agreed that only the amounts due the Consultant for services provided and expenses incurred to the date of termination will be due and payable. No penalty will be assessed for termination of this Agreement.

X.  
Amendment or Modification

Except as otherwise provided in this Agreement, this Agreement shall be subject to change, amendment, or modification only upon the written consent of the parties hereto, executed by authorized representatives of both parties to this Agreement.

XI.  
Miscellaneous

1. Choice of Law. This Agreement shall be construed and given effect in accordance with the laws of the State of Texas, including all matters of construction, validity, performance and enforcement.
2. Binding Effect; Assignment. This Agreement shall be binding upon and inure to the benefit of the Client and the Consultant, their respective successors and assigns; provided however, that neither party hereto may assign or transfer any of its rights or obligations hereunder without the prior written consent of the other party.
3. Entire Agreement. This instrument contains the entire agreement between the parties relating to the rights herein granted and obligations herein assumed. Any oral or written representations or modifications concerning this Agreement shall be of no force or effect except for a subsequent modification in writing signed by all parties thereto.
4. Waiver. A waiver by either party of a breach of any of the terms or provisions of this Agreement shall not operate or be construed as a waiver of any subsequent breach.

[EXECUTION PAGE FOLLOWS]



XII.

Acceptance

This instrument is being executed in two (2) counterpart originals, each of which has the full force and effect of an original. Execution of this Agreement also indicates acceptance that payment is due for services rendered, including those instances where, for whatever reason, the TCEQ fails to create a municipal management district or the City of Houston fails to create a public improvement district.

This Agreement is made and entered into in Harris County, Texas, and venue for all purposes shall be in Harris County, Texas.

AGREED AND ACCEPTED THIS \_\_\_\_\_ DAY OF \_\_\_\_\_, 2020.

**On Behalf of HOBBY AREA DISTRICT**

By: \_\_\_\_\_  
Name: \_\_\_\_\_  
Title: \_\_\_\_\_  
Address: \_\_\_\_\_  
City/State/Zip \_\_\_\_\_

**On Behalf of HAWES HILL & ASSOCIATES, LLP:**

By: 

DAVID W. HAWES  
Hawes Hill & Associates, LLP  
PO Box 22167  
Houston TX 77227-2167  
Telephone 713-595-1200  
Fax 281-888-6314  
E-mail [dhawes@haweshill.com](mailto:dhawes@haweshill.com)



# CERTIFICATE OF INTERESTED PARTIES

FORM 1295

1 of 1

Complete Nos. 1 - 4 and 6 if there are interested parties.  
 Complete Nos. 1, 2, 3, 5, and 6 if there are no interested parties.

## OFFICE USE ONLY CERTIFICATION OF FILING

**1 Name of business entity filing form, and the city, state and country of the business entity's place of business.**  
 Hawes Hill & Associates LLP  
 HOUSTON, TX United States

Certificate Number:  
 2020-673285

Date Filed:  
 09/30/2020

**2 Name of governmental entity or state agency that is a party to the contract for which the form is being filed.**  
 Hobby Area District

Date Acknowledged:

**3 Provide the identification number used by the governmental entity or state agency to track or identify the contract, and provide a description of the services, goods, or other property to be provided under the contract.**

2020920  
 supplemental consulting services -- intergovernmental relations

4	Name of Interested Party	City, State, Country (place of business)	Nature of interest (check applicable)	
			Controlling	Intermediary

**5 Check only if there is NO Interested Party.**

**6 UNSWORN DECLARATION**

My name is Lesley Susan Hill, and my date of birth is Aug. 8, 1948.

My address is 9610 Long Point Road # 150, Houston, TX, 77055.  
(street) (city) (state) (zip code) (country)

I declare under penalty of perjury that the foregoing is true and correct.

Executed in Harris County, State of Texas, on the 1<sup>st</sup> day of Oct., 2020.  
(month) (year)

Lesley Hill  
 Signature of authorized agent of contracting business entity  
 (Declarant)



## HOBBY AREA DISTRICT

(HARRIS COUNTY IMPROVEMENT DISTRICT NO. 9)  
CITY OF HOUSTON  
HARRIS COUNTY, TEXAS

---

---

### AGENDA MEMORANDUM

---

---

To: Hobby Area District Board of Directors  
From: Executive Director  
Subject: Agenda Item Materials

---

8. Authorize Executive Director to set date, time, and place for hearing on Supplemental Assessment Roll and Appoint Hearing Examiner.



## HOBBY AREA DISTRICT

(HARRIS COUNTY IMPROVEMENT DISTRICT NO. 9)  
CITY OF HOUSTON  
HARRIS COUNTY, TEXAS

---

---

### AGENDA MEMORANDUM

---

---

To: Hobby Area District Board of Directors  
From: Executive Director  
Subject: Agenda Item Materials

---

9. Authorize Executive Director to prepare and solicit requests for qualifications and proposals for bookkeeping and accounting services.





## HOBBY AREA DISTRICT

(HARRIS COUNTY IMPROVEMENT DISTRICT NO. 9)

CITY OF HOUSTON

HARRIS COUNTY, TEXAS

---

---

### AGENDA MEMORANDUM

---

---

To: Hobby Area District Board of Directors  
From: Executive Director  
Subject: Agenda Item Materials

---

10. Authorize Executive Director to enter into a contract with a new payroll provider.

## Price Scale

# of Checks	Fee	# of Checks	Fee
1	\$34.65	50	\$87.50
5	\$41.25	55	\$91.75
10	\$49.75	60	\$96.00
15	\$57.75	65	\$100.25
20	\$62.00	70	\$104.50
25	\$66.25	75	\$108.75
30	\$70.50	80	\$113.00
35	\$74.25	85	\$117.25
40	\$79.00	90	\$121.50
45	\$83.25	95	\$125.75
		100	\$130.00

## Enterprise Pricing

# of Checks	\$20 base fee +
101-249	\$1.20 per check
250-499	\$1.18 per check
500-749	\$1.16 per check
750-999	\$1.14 per check
1000-1499	\$1.12 per check
1500-1999	\$1.10 per check
2000-2499	\$1.08 per check
2500-4999	\$1.06 per check
5000-7499	\$1.04 per check

## Year End Items

# of W-2's/1099's/1095's	\$50 base fee +
1-25	\$5.75ea
26-499	\$4.75ea
500-999	\$3.75ea
1000+	\$2.75ea

\*\$50 base fee applies to W-2's, 1099's and 1095's.

(800) 789-7655 • [www.alliancepayroll.com](http://www.alliancepayroll.com)

## Optional Services

### Complete Tax Filing

\$13 per payroll per entity up to 3 states (\$10 per month per state after 3)

### Direct Deposit/Paycards

\$5 base fee plus \$0.35 per transaction

### All-Check Payment Service

\$5 base fee plus \$0.35 per check

### New Hire Reporting

\$2 per new hire

### Garnishment Checks

\$1.50 per check

### General Ledger

\$10 per month

### Time Off Accruals

\$10 per month

### SSN Verification

\$1.00 each

## Additional Modules

### ACA Management

\$1.25 \*pepm

### Time and Attendance

\$2.50 \*pepm

### Employee Self-Serve

\$0.25 (Silver), \$0.50 (Gold), \$1.50 (Platinum)  
\*pepm

### HR/Benefits

\$1.00 \*pepm

Carrier Connect - \$0.75 \*pepm

### Applicant Tracking

\$2.50 per new hire

### Onboarding

\$5.00 per new hire

### Work Opportunity Tax Credits

10% of credit found

\*PEPM – Per Employee Per Month



**INTERNAL USE ONLY**

CLIENT # \_\_\_\_\_

EIN \_\_\_\_\_

**PAYROLL PROCESSING AGREEMENT**

**A. CLIENT LEGAL NAME:** \_\_\_\_\_

DBA: \_\_\_\_\_

Address: \_\_\_\_\_

City: \_\_\_\_\_ State: \_\_\_\_\_ Zip: \_\_\_\_\_

Contact: \_\_\_\_\_

Phone: \_\_\_\_\_ Email: \_\_\_\_\_

**B. BANK AUTHORIZATION**

Name of Depositor (as shown on bank records): \_\_\_\_\_

Bank Name: \_\_\_\_\_

Bank Address: \_\_\_\_\_

Bank Account Number: \_\_\_\_\_ Routing Number: \_\_\_\_\_

As a convenience to me, I hereby request and authorize you to pay and charge to my account debits originated by and payable to the order of **Alliance Payroll Services, Inc.**, provided there are sufficient collected funds in said account to pay the same. This authorization includes debits (herein "item") originated by check or electronic funds transfer. I agree that your rights in respect to each said item shall be the same as if it were a check drawn on you and signed personally by me. This authority is to remain in effect until revoked by me in writing, and until you actually receive such notice I agree that you shall be fully protected in honoring such item.

I further agree that if any such item be dishonored whether with or without cause and whether intentionally or inadvertently, you shall be under no liability whatsoever even though such occurrences result in termination of our agreement.

**C. ADDITIONAL TERMS AND CONDITIONS**

This agreement may be cancelled at any time upon written notice to **Alliance Payroll Services, Inc.**

The following Additional Terms and Conditions apply to and are incorporated as a material portion of the Agreement between the Client identified on the face of the Agreement and **Alliance Payroll Services, Inc.**

**TERMS OF THE AGREEMENT:**

Either party may cancel this Agreement upon written notice to the other party. Such cancellation will not effect the liability of Client to pay Alliance any sums due and owing under the Agreement as of the effective date of cancellation.

**ALLIANCE PAYROLL SERVICES, INC. RESPONSIBILITIES:**

1. Alliance agrees to keep confidential any information provided by the Client relating to its assets, liabilities, business or affairs, and not to disclose this information to anyone without the permission of the Client, or unless forced to do so by legal process.
2. Alliance will use due care in processing Client's work, and shall be responsible for correcting errors which are caused by Alliance equipment, processors, programmers, or employees in the course of their work. Alliance will not be responsible for failure to provide services or correct any condition beyond its control, including but not limited to any acts or omissions by any third party. **ALLIANCE SHALL NOT UNDER ANY CIRCUMSTANCES BE LIABLE FOR SPECIAL, INDIRECT, INCIDENTAL OR CONSEQUENTIAL DAMAGES**, even if Alliance has been advised of the possibility of such damages.
3. If Client and Alliance agree to have Alliance prepare and file payroll tax returns for Client, Alliance will serve as a limited agent for Client, only for purposes of any required agency for payroll tax deposits and filing with the Internal Revenue Service and/or any state reporting agency. Alliance is not otherwise an agent of Client, nor is Alliance in partnership or otherwise affiliated with Client's business.
4. If Alliance makes an error or omission which results in an assessment by any taxing authority against the Client which results in interest or penalties then Alliance will pay the interest or penalties. It will remain the Client's responsibility to pay any tax due. This is the sole liability as it pertains to tax payments, and is Client's sole remedy pertaining to tax payments. Client agrees to allow Alliance to participate in defending against any claim for any penalties or interest, and to subrogate any such claim or defense to Alliance.

(continued)

**Personalized Service • Better Software • Lower Costs**

**9110 Forest Crossing • The Woodlands, TX 77381 • Phone (800) 789-7655 • Fax (832) 616-3553**



- 5. Except as specifically stated in the Agreement, there are no warranties, expressed or implied, including but not limited to any implied warranties of merchantability or fitness for a particular purpose.

**CLIENT'S RESPONSIBILITIES:**

- 1. Client will submit to Alliance its payroll data in a form, at a time and by a method specified by Alliance. Because the accuracy of the payroll is limited to the Client's data, Alliance will not be responsible for Client errors, wage and hour violations, employment discrimination, or other employment policies which may violate the law. It is the Client's responsibility to review the processed payroll information and to promptly identify the errors. If an error is Alliance's responsibility, then Alliance will assume the cost of correction. If the data submitted by Client for processing is incorrect, incomplete, or not in proper form, the Client agrees to pay Alliance additional charges then in effect for corrections to this date.
- 2. If Client chooses to utilize Alliance Trust Bank Accounts for its payroll, Client agrees to authorize Alliance to debit from its account(s) on or about the specified date of each processing day such sums as are required to adequately fund the Clients payroll, including any taxes, escrows, benefit plans, withholdings, adjustments, or other associated fees and charges. Should any preauthorized transfer or other tender of funds to Alliance be returned unpaid for any reason whatsoever, Client agrees to pay Alliance an additional fee and Alliance has at its sole option, the right to cancel this Agreement and to immediately terminate any limited agency for Client which might exist for purposes of tax filings or any other purpose.
- 3. Fees are subject to change upon written notice to Client. Client agrees to allow Alliance to debit from its account(s) any and all fees due Alliance under this agreement, if Alliance, in its sole discretion chooses to do so.
- 4. If the Client fails to pay the fees or any other charges, including an amount authorized for debit on the payroll itself, within the terms outline in this Agreement, then Client agrees to pay Alliance for all costs of collections, including reasonable attorneys fees, which may be associated with the collection of the amounts due. If Client fails to pay any fees or charges when due, then Alliance may, at its sole option, terminate this Agreement and withhold any work in progress. This is in addition to any other rights Alliance may have under this contract or under law. To secure the Client's payment of fees or other charges due under this Agreement, Client grants to Alliance the right of setoff and a security interest under the Uniform Commercial Code in any funds which may have been or will be deposited by Client in its escrow account or otherwise retained by Alliance for purposes of remitting tax payments when due.
- 5. Client agrees to indemnify and hold Alliance harmless from all loss, damages and expenses (including reasonable attorney's fees) in connection with any claim which may arise out of or as a result of this Agreement or the duties assumed by Alliance under the Agreement.
- 6. Client agrees to obtain (if necessary) and maintain appropriate tax identification numbers for its own tax reporting, and to obtain and maintain any necessary tax forms and information from its employees, and to forward this information to Alliance upon request.
- 7. IRS Form 8655 Notice - As Alliance Payroll Services, Inc. is making tax deposits on behalf of your company, the IRS requires us to have you to sign IRS Form 8655 - Reporting Agent Authorization. As noted in the Authorization Agreement section of form 8655, this authorization does not relieve the taxpayer of the responsibility to ensure that tax returns are filed and deposits are made. The IRS requires all reporting agents (which payroll services are) to notify you of this responsibility when you contract with their service. In addition, Alliance Payroll Services and the IRS recommend that you enroll in the Electronic Federal Tax Payment System if you desire to monitor your federal tax payments we make on your behalf. If your company does not already have an EFTPS account, you may receive one by enrolling online at [www.eftps.com](http://www.eftps.com) and selecting the enrollment tab.

Signature	Date

Print Name	Title

Accepted By	Date

Personalized Service • Better Software • Lower Costs

9110 Forest Crossing • The Woodlands, TX 77381 • Phone (800) 789-7655 • Fax (832) 616-3553

**ACH SERVICE AGREEMENT**

This agreement is between \_\_\_\_\_ ("Company") and Alliance Payroll Services, Inc. ("Processor"). This agreement is for Automated Clearing House (ACH) services to be utilized by our Company which has deposit accounts with financial institutions that participate in the National Automated Clearing House Association (NACHA), hereinafter called Participating Institutions. ACH transactions will be the agreed upon method of debiting/crediting accounts between the Company and the Processor. As a result, both parties will agree as follows:

1. Services using ACH transfers shall be provided to the Company in accordance with the NACHA Operating Rules, as well as all other applicable regulations pertaining to ACH. The Company shall be considered the "Originator" participant under all applicable NACHA Operating Rules (Rules) in connection with any ACH items submitted by the Processor on behalf of the Company. As an Originator, the Company must comply with and are bound by the Rules. The Company shall be liable to the Participating Institutions with respect to the warranties, liabilities, and/or obligations relating to ACH entries.
2. The Company authorizes the Processor to process ACH transactions to pay the Company's employees and draft the Company for total direct deposits, billing, taxes and/or trust. Also, the Processor may debit employee accounts for corrections as needed.
3. The Company acknowledges that each debit/credit submitted is, to their knowledge, authorized, accurate, timely, and in compliance with the Rules and federal and state laws and regulations governing electronic funds transfer.
4. The Company agrees to not originate ACH entries, or participate in the origination of ACH entries, that violate the laws of the United States or other governing jurisdictions.
5. The Company will retain the original, or a copy, of each employee's direct deposit authorization for such period of time as may be required by the Rules or applicable law.
6. The Processor will only originate ACH PPD (Prearranged Payment or Deposit) transactions on behalf of the Company.
7. The Processor reserves the right to require a wire or reverse wire to fund the payroll amounts processed prior to releasing direct deposits, checks drawn on the Processor's account and/or taxes.
8. The Processor reserves the right to terminate the processing of ACH items if the Company is in violation of the Rules or applicable laws or if the customer becomes fiscally unstable.
9. The Company agrees to submit payroll data prior to the deadline established by Processor. The current deadline is 48 hours prior to payroll date.
10. The Processor reserves the right to examine and audit the Company's compliance with the original agreement and the NACHA Rules at any time.

\_\_\_\_\_  
Signature

\_\_\_\_\_  
Title

\_\_\_\_\_  
Print Name

\_\_\_\_\_  
Date

**Personalized Service   •   Better Software   •   Lower Costs**

9110 Forest Crossing • The Woodlands, TX 77381 • Phone (800) 789-7655 • Fax (281) 875-3838



## HOBBY AREA DISTRICT

(HARRIS COUNTY IMPROVEMENT DISTRICT NO. 9)  
CITY OF HOUSTON  
HARRIS COUNTY, TEXAS

---

---

### AGENDA MEMORANDUM

---

---

To: Hobby Area District Board of Directors  
From: Executive Director  
Subject: Agenda Item Materials

---

11. Authorize Executive Director to enter into a contract with Smartscape for quarterly mowing/clean-up along the BNSF rail line.



HOBBY AREA MANAGEMENT DISTRICT BID TAB FOR MYKAWA RD BNSF RAILROAD DEBRIS PILE CLEANUP

SEPTEMBER 3, 2020

<b>Contractor</b>	<b>1 Time Removal Only*</b>	<b>Quarterly Mowing and Litter Abatement Rate</b>
SMC 12200 Carlsbad St Houston TX 77985	\$1,600.00	\$2,750.00
SMARTSCAPING PO Box 21211 Houston TX 77226	\$950.00	\$950.00
DONNY'S JUNK REMOVAL 6135 Pecan Wood Dr Houston TX 77088	No Proposal	No Proposal
JUNK KING 7117 Belgold Dr Suite B Stafford TX 77477	No Proposal	No Proposal
TRASH N DASH 3220 Cypress Creek Pkwy, A11 Houston TX 77068	No Proposal	No Proposal

\*Initial Mykawa Cleanup Quote from Airport to Dixie. The quote includes mowing/trimming around the debris piles in order to access the debris

- For Cleanup, the limits of the project are from Dixie to Airport along Mykawa



# Smartscaping

PO Box 21211 | Houston, Texas 77226  
832-513-3800 | smartscaping2014@gmail.com | www.smartscaping.co

**RECIPIENT:**

**Hobby Management District**

8121 Broadway  
Houston, TX

**SERVICE ADDRESS:**

Mykawa Road  
Houston, Texas

Quote #5	
Sent on	Sep 01, 2020
<b>Total</b>	<b>\$3,800.00</b>

PRODUCT / SERVICE	DESCRIPTION	QTY.	UNIT COST	TOTAL
Mykawa Road Clean Up - 1st Quarter	Cut Grass and Pick Up Trash from Mykawa Road at Dixie Road to Mykawa Road at Airport (2.5 miles of Railroad Right of Way)	2.5	\$380.00	\$950.00
Mykawa Road Clean Up - 2nd Quarter	Cut Grass and Pick Up Trash from Mykawa Road at Dixie Road to Mykawa Road at Airport (2.5 miles of Railroad Right of Way)	2.5	\$380.00	\$950.00
Mykawa Road Clean Up - 3rd Quarter	Cut Grass and Pick Up Trash from Mykawa Road at Dixie Road to Mykawa Road at Airport (2.5 miles of Railroad Right of Way)	2.5	\$380.00	\$950.00
Mykawa Road Clean Up - 4th Quarter	Cut Grass and Pick Up Trash from Mykawa Road at Dixie Road to Mykawa Road at Airport (2.5 miles of Railroad Right of Way)	2.5	\$380.00	\$950.00

**Total** **\$3,800.00**

This quote is valid for the next 30 days, after which values may be subject to change.

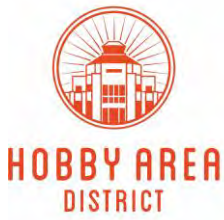

## PROPOSAL EVALUATION SCORE SHEET

**Project:**     **BNSF ROW Mowing and Litter Abatement (quarterly)**  
                   - **Smartscape**

**Reviewer:**   **Beth Strobe**

Item/Criteria	Points	Score
Timeliness in proposal submission	0-5	4
Measurable outcomes are clearly identified and specifically address the goals and/or objectives as identified by this proposal.	0-5	4
Responsiveness of vendor	0-5	4
Insurance Requirements Met	0-5	5
The proposal describes the types of services to be provided.	0-5	5
The proposed budget is appropriate for accomplishing the identified objectives and contains all elements for the proposed project that are required by this RFP.	0-5	5
The applicant has demonstrated experience, knowledge, and potential to accomplish what is being proposed.	0-5	5
<b>TOTAL SCORE:</b>	0-35	32

A minimum score of seventy-five percent (75%) in criteria areas is required to be a considered for an award of a contract.





## PROPOSAL EVALUATION SCORE SHEET

**Project:**     **BNSF ROW Mowing and Litter Abatement (quarterly)**  
                   - **Smartscape**

**Reviewer:**   **Buddy Tautenhahn**

Item/Criteria	Points	Score
Timeliness in proposal submission	0-5	4
Measurable outcomes are clearly identified and specifically address the goals and/or objectives as identified by this proposal.	0-5	4
Responsiveness of vendor	0-5	4
Insurance Requirements Met	0-5	5
The proposal describes the types of services to be provided.	0-5	5
The proposed budget is appropriate for accomplishing the identified objectives and contains all elements for the proposed project that are required by this RFP.	0-5	5
The applicant has demonstrated experience, knowledge, and potential to accomplish what is being proposed.	0-5	5
<b>TOTAL SCORE:</b>	0-35	32

A minimum score of seventy-five percent (75%) in criteria areas is required to be a considered for an award of a contract.



August 19<sup>th</sup>, 2020

PROPOSAL 055

Beth Strobe  
Hobby Area District  
8121 Broadway St  
Suite 199  
Houston, TX 77061

Proposal for Mykawa Railroad

### **DESCRIPTION**

De-litter and mow the ditch along the Mykawa Rd railroad between the intersections of Airport Blvd and Dixie Dr. Per instructions of Hobby Area District personnel, the requirement of this project is to only mow from the ditch to the Right-of-Way and not to the gravel. This quote is priced accordingly for the preliminary de-litter and mow effort and for quarterly cuts.

### **PRICE**

#### **Initial Rates**

Liter Abatement Rates: \$1,600  
Mowing and Weed Eating Rates: \$10,900  
**Total Charge: \$12,500**

#### **Quarterly Rates**

Liter Abatement Rates: \$1,600  
Mowing and Weed Eating Rates: \$9,400  
**Total Charge: \$11,000**

## Mykawa Railroad Clean-Up Airport Blvd to Dixie Dr.















Conditions of Proposal

1. **Acceptance of Proposal and Insurance:**  
This proposal is based on the current prices of labor and is subject to revision after 30 days from the date hereof if not accepted within 30 days from the date hereof. Acceptance of this proposal shall be signified by returning the signed copy to Contractor, after which this proposal will become a contract (this "Contract") between Contractor and Owner. Contractor shall maintain Liability and Workman's Compensation Insurance at all times. Certificate of Insurance are available upon request.
2. **Scheduling:**  
Work will be scheduled upon Contractor's receipt of Owner's acceptance of this proposal, and will promptly commence as decided solely by Contractor. Contractor shall not be held responsible for delay caused by fire, civil, or military authority or by natural causes beyond the contractor's control.
3. **Repairs Needed:**  
Changes in the scope of work from this Contract shall be effective only by a signed changed order. If a change order deletes special material already purchased by Contractor prior to the change order, Owner remains liable for payment thereof to Contractor, and shall be responsible for the disposition of said material at no cost to Contractor.
4. **Grading, Property Boundary and Underground Obstacles/Utilities:**  
Unless otherwise specified, Contractor will receive the site at Finish grade of +/- .01'. Contractor will not be responsible for drainage of water onto, across, or from Owner's assigned agent to establish the legal lines of Owner's property. It is Contractor's responsibility to have underground utilities marked by Texas One Call. Buried rock, debris, or underground utilities requiring additional labor or equipment shall be covered by signed change order and invoiced to Owner on a cost-plus 25% basis.
5. **Cancellation:**  
Both parties agreed that this proposal, upon acceptance, may not be cancelled without written consent of Contractor. If cancelled a sum equal to 20% of the contract price shall be paid to Contractor by the owner or assigned agent as liquidating damages. All Correspondence regarding cancellation shall be via email, fax or certified mail.
6. **Payment:**  
Payment is due and payable as detailed on the invoice; otherwise, due upon receipt of invoice and payable at the office of Contractor. Invoices over 30 days past due are subject to the service charge equal to 1.5% per month (18% per year) multiplied by the unpaid balance. In addition to the service charge, owner shall reimburse Contractor for all cost and expenses (including but not limited to attorneys' fees and court cost) which are reasonably incurred by Contractor in collecting Owner's delinquent account.

THIS AGREEMENT IS ENTERED INTO AS A OF THE DATE FIRST WRITTEN ABOVE.

**If the signed below is not the Owner, by signing this proposal, the signer hereby represents and warrants on behalf of Owner that the signer has full power and authority from Owner to do so; and that this signed proposal becomes and is a legally binding obligation of Owner. If signer is other than the record owner of the location(s) where the work is to be performed, the signer represents and warrant that signer has full power and authority to enter into the terms of this Contract of behalf of itself and such record owner and that this Contract is a binding obligation of the record owner of the Site.**

By \_\_\_\_\_

Sonia J. Chavez

8/19/2020

Date \_\_\_\_\_

SMC LOGISTICS, LLC DBA SMC Landscape Services

By \_\_\_\_\_

Date \_\_\_\_\_



## PROPOSAL EVALUATION SCORE SHEET

**Project:** BNSF ROW Mowing and Litter Abatement (quarterly)  
- SMC

**Reviewer:** Beth Strobe

Item/Criteria	Points	Score
Timeliness in proposal submission	0-5	4
Measurable outcomes are clearly identified and specifically address the goals and/or objectives as identified by this proposal.	0-5	5
Responsiveness of vendor	0-5	4
Insurance Requirements Met	0-5	5
The proposal describes the types of services to be provided.	0-5	5
The proposed budget is appropriate for accomplishing the identified objectives and contains all elements for the proposed project that are required by this RFP.	0-5	3
The applicant has demonstrated experience, knowledge, and potential to accomplish what is being proposed.	0-5	5
<b>TOTAL SCORE:</b>	0-35	31

A minimum score of seventy-five percent (75%) in criteria areas is required to be a considered for an award of a contract.





## PROPOSAL EVALUATION SCORE SHEET

**Project:** BNSF ROW Mowing and Litter Abatement (quarterly)  
- SMC

**Reviewer:** Buddy Tautenhahn

Item/Criteria	Points	Score
Timeliness in proposal submission	0-5	3
Measurable outcomes are clearly identified and specifically address the goals and/or objectives as identified by this proposal.	0-5	4
Responsiveness of vendor	0-5	4
Insurance Requirements Met	0-5	5
The proposal describes the types of services to be provided.	0-5	5
The proposed budget is appropriate for accomplishing the identified objectives and contains all elements for the proposed project that are required by this RFP.	0-5	2
The applicant has demonstrated experience, knowledge, and potential to accomplish what is being proposed.	0-5	5
<b>TOTAL SCORE:</b>	0-35	28

A minimum score of seventy-five percent (75%) in criteria areas is required to be a considered for an award of a contract.



## HOBBY AREA DISTRICT

(HARRIS COUNTY IMPROVEMENT DISTRICT NO. 9)  
CITY OF HOUSTON  
HARRIS COUNTY, TEXAS

---

---

### AGENDA MEMORANDUM

---

---

To: Hobby Area District Board of Directors  
From: Executive Director  
Subject: Agenda Item Materials

---

12. Discuss and authorize FY2021 Budget.

**FY 2018\_FY 2019\_FY 2020 BUDGET**

		FY 2017 Budget	FY 2018 Budget	FY 2019 Budget	FY 2020 Budget	FY 2021 Proposed Budget	Change
<b>Income- M&amp;O SOURCES OF FUNDS</b>							
4000	District Assessments	1,825,614	1,882,401	1,900,000	1,900,000	2,202,430	302,430
4010	Penalty & Interest Revenue	36,000	36,000	25,000	36,000	28,755	(7,245)
4020	Overpayments	66,000	66,000	67,000	67,000	67,000	0
4030	Assessment Refunds	(66,500)	(66,500)	(68,000)	(68,000)	(70,000)	(2,000)
4050	Grant and Donations	0	0	0	0	0	0
4060	Interest Revenue	4,500	4,500	15,000	20,000	20,000	0
4065	Non-Income Funds		557,432	0	0	0	0
	Scenic Houston		357,432	0	0	0	0
	METRO Reimbursement		200,000	7,500	0	0	0
<b>Total Income</b>		1,865,614	2,479,833	1,946,500	1,955,000	2,248,185	293,185
<b>Expense- M&amp;O USES OF FUNDS</b>							
<b>Public Safety</b>							
6010	Contract Public Safety	219,024	230,000	275,000	302,500	305,000	2,500
****	HAD Police Task Force					410,346	410,346
6012	Site Specific High Density Patrols (Hot Sp	91,520	100,000	25,000	65,000	0	(65,000)
6014	Special Operations (HPD Crime Initiative]	40,000	10,000	10,000	120,000	0	(120,000)
6015	Apartment Life Initiatives-RCR	25,000	20,000	20,000	22,500	22,500	0
6020	Mobile Cameras	81,000	83,430	10,000	45,000	45,000	0
6025	Nuisance Abatement/Code Enforcement	0	15,000	15,000	15,000	15,000	0
6035	Graffiti Abatement	35,000	35,000	37,500	42,000	42,000	0
6037	Public Safety Programs		2,500	4,000	4,400	4,400	0
6040	Staff Allocation	72,825	108,045	187,927	0	0	0
**	County Attorney Interlocal agreement	0	0	0	0	49,690	49,690
<b>Total Public Safety</b>		564,369	603,975	584,427	616,400	893,936	277,536



**FY 2018\_FY 2019\_FY 2020 BUDGET**

		FY 2017 Budget	FY 2018 Budget	FY 2019 Budget	FY 2020 Budget	FY 2021 Proposed Budget	Change
<b>Community Development</b>							
<b>6051</b>	<b>Community Enhancement Programs</b>	240,000	<b>81,000</b>	<b>81,000</b>	<b>91,000</b>	<b>11,000</b>	<b>(80,000)</b>
	Trail Lights replacement		5,000	5,000	5,000	5,000	0
	Trail Lights Power		1,000	1,000	1,000	6,000	5,000
	Neighborhood sign grant	40,000	40,000	40,000	50,000	0	(50,000)
	Façade improvement grant Gateway Monuments (previous code used-8072)		35,000	35,000	35,000	0	(35,000)
			0	0	0	0	0
<b>6053</b>	<b>Field Services Vehicle</b>	<b>0</b>	<b>0</b>	<b>39,750</b>	<b>11,200</b>	<b>11,200</b>	<b>0</b>
	Vehicle Purchase		0	30,000	0	0	0
	Maintenance		0	3,000	3,000	3,000	0
	Fuel		0	1,750	3,200	3,200	0
	Equipment and Repairs		0	5,000	5,000	5,000	0
<b>6050</b>	<b>Porter Service</b>	<b>150,000</b>	<b>163,000</b>	<b>165,000</b>	<b>165,000</b>	<b>178,500</b>	<b>13,500</b>
	<b>SMC Logistics</b>						
<b>6052</b>	<b>Corridor and ROW Maintenance</b>	<b>140,000</b>	<b>315,000</b>	<b>365,000</b>	<b>415,000</b>	<b>262,500</b>	<b>(152,500)</b>
	Broadway		140,000	140,000			
	I-45 ROW		35,000	85,000			
	Airport Corridor Interlocal Agreement		125,000	125,000			
	Trash Pickup (Broadway)		15,000	15,000			
<b>6054</b>	<b>Street Sweeping</b>	<b>75,000</b>	<b>75,000</b>	<b>86,000</b>	<b>90,000</b>	<b>90,000</b>	<b>0</b>
<b>8063</b>	<b>Esplanade/Roadway Enhancement</b>	<b>50,000</b>	<b>50,000</b>	<b>50,000</b>	<b>50,000</b>	<b>50,000</b>	<b>0</b>
<b>8065</b>	<b>METRO Bus Shelter Maintenance</b>	<b>400,000</b>	<b>569,287</b>	<b>145,750</b>	<b>22,000</b>	<b>31,000</b>	<b>9,000</b>
	Contract Award		532,287	0	0	0	0
	Clark Condon Contract 116-044B		15,000	0	0	0	0
	Bus Shelter Replacement		22,000	22,000	22,000	22,000	0
	Maintenance Agreement			123,750	0	0	0
<b>8074</b>	<b>Streetscape Accessories</b>	<b>35,000</b>	<b>6,400</b>	<b>7,000</b>	<b>7,000</b>	<b>0</b>	<b>(7,000)</b>
<b>8055</b>	<b>Project/Contract Management - Consult:</b>	<b>200,000</b>	<b>125,000</b>	<b>105,000</b>	<b>125,000</b>	<b>220,400</b>	<b>95,400</b>

**FY 2018\_FY 2019\_FY 2020 BUDGET**

	Hawes Hill	75,000	55,000	75,000	170,400	95,400
	Other CD Consultants	50,000	50,000	50,000	50,000	0
<b>6055</b>	<b>Staff Allocation</b>	<b>52,318</b>	<b>79,205</b>	<b>141,337</b>	<b>0</b>	<b>0</b>
	<b>Total Community Development</b>	<b>1,342,318</b>	<b>1,463,892</b>	<b>1,185,837</b>	<b>976,200</b>	<b>(121,600)</b>
<hr/>						
		<b>FY 2017 Budget</b>	<b>FY 2018 Budget</b>	<b>FY 2019 Budget</b>	<b>FY 2020 Budget</b>	<b>FY 2021 Proposed Budget</b>
						<b>Change</b>
<b>Economic Development</b>						
<b>6060</b>	<b>Economic Development Programs</b>	<b>90,000</b>	<b>90,000</b>	<b>108,800</b>	<b>100,000</b>	<b>2,000</b>
	Xceligent (Co-Star)		5,700	0	6,000	0
	BEDC		250	0	0	0
	Business Ambassador		40,000	40,000	60,000	0
	CDI		400	0	0	0
	ICSC Dallas		1,500	1,500	0	0
	IEDC Conference		1,500	8,000	8,000	0
	TEDC Annual Conference		500	2,000	2,000	0
	TEDC Legislative and Site Selectors			1,000	1,000	2,000
	TEDC Sales Tax Workshop		200	0	0	0
	OTC		1,000	5,000	0	0
	Team Texas		6,000	8,000	8,000	0
	Select USA		2,500	2,550	0	0
	Site Selectors Guild		3,000	3,000	3,000	0
	IAMC		2,500	0	0	0
	SEDC			5,250	0	0
	Valve World Exp		500	500	0	0
	Partner Initiatives			20,000	0	0
	Other Eco Devo Programs		24,450	12,000	12,000	0
<b>8050</b>	<b>Eco Devo Strategic Plan</b>	<b>25,000</b>	<b>72,500</b>	<b>0</b>	<b>0</b>	<b>0</b>
	Avalanche		72,500		0	0
						0

**FY 2018\_FY 2019\_FY 2020 BUDGET**

<b>8053</b>	<b>Market Feasibility Study (Bellfort Station</b>	<b>50,000</b>	<b>300,000</b>	<b>100,000</b>	<b>100,000</b>	<b>0</b>	<b>(100,000)</b>
	Bellfort Station Initiative		300,000			0	0
<b>6080</b>	<b>Staff Allocation</b>	<b>90,426</b>	<b>107,985</b>	<b>134,206</b>	<b>0</b>	<b>0</b>	<b>0</b>
	<b>Total Economic Development</b>	<b>255,426</b>	<b>570,485</b>	<b>343,006</b>	<b>200,000</b>	<b>2,000</b>	<b>(198,000)</b>
<hr/>							
<b>Communications, Public Affairs, Marketing</b>							
		<b>FY 2017 Budget</b>	<b>FY 2018 Budget</b>	<b>FY 2019 Budget</b>	<b>FY 2020 Budget</b>	<b>FY 2021 Proposed Budget</b>	<b>Change</b>
<b>6068</b>	<b>CPA&amp;M Programs</b>	<b>0</b>	<b>22,000</b>	<b>20,200</b>	<b>0</b>	<b>0</b>	<b>0</b>
	AMAC (Airport Minority Advisory Council) Conference		1,800	0	0	0	0
	IEDC Econ. Dev. Mktg. and Attraction Course (Various courses for 20:		1,800	1,800	0	0	0
	PRSA Nonprofit Marketing Conference (July)-TBD		2,000	2,000	0	0	0
	Additional Industry Related Conferences (Ex. AAEE, etc.)		15,000	15,000	0	0	0
	ACI (Airports Council International) (TBD)		1,400	1,400	0	0	0
<b>6065</b>	<b>Events</b>	<b>20,000</b>	<b>35,500</b>	<b>35,000</b>	<b>36,500</b>	<b>26,500</b>	<b>(10,000)</b>
	Various GHP Sponsorships		2,500	2,500	2,500	2,500	0
	PIP		1,500	1,500	1,500	1,500	0
	Quarterly Breakfast/Social		4,000	4,000	5,000	5,000	0
	State of the City Luncheon Sponsorship		2,500	2,500	2,500	2,500	0
	Community Outreach Event		10,000	10,000	10,000	7,500	(2,500)
	Hobby Area District Open House		5,000	5,000	5,000	0	(5,000)
	Other Sponsorships/Events TBD		10,000	10,000	10,000	7,500	(2,500)
<b>6070</b>	<b>Creative Support</b>	<b>45,000</b>	<b>52,500</b>	<b>62,500</b>	<b>107,500</b>	<b>68,200</b>	<b>(39,300)</b>
	Social Media Management		15,000	15,000	65,000	36,000	(29,000)
	Editorial Direction		10,000	15,000	15,000	7,200	(7,800)
	Website Reconstruction		10,000	10,000	5,000	0	(5,000)
	Web Manager			5,000	5,000	0	(5,000)
	Graphic Designer		17,500	17,500	17,500	25,000	7,500
<b>6075</b>	<b>Marketing Mtls &amp; Promo Items</b>	<b>50,000</b>	<b>50,000</b>	<b>50,000</b>	<b>50,000</b>	<b>25,000</b>	<b>(25,000)</b>
	HAD Media Kits						
	HAD Shirts						



**FY 2018\_FY 2019\_FY 2020 BUDGET**

	HAD Umbrellas							
	HAD Name Tags							
	HAD Corporate/Business Gifts							
	HAD Coffee Mugs							
	HAD Coasters							
<b>6235</b>	<b>Hobby Area Improvement Corporation</b>	<b>50,000</b>	<b>50,000</b>	<b>50,000</b>	<b>50,000</b>	<b>50,000</b>	<b>50,000</b>	<b>0</b>
	State of The District							
	HobbyFest 2018 Festival							
	HobbyFest 2018 Scholarships							
	HobbyFest 2018 Planning Meetings-9							
	Creative support for HAD signature events							
	HobbyFest Event/Sponsorship Manager							
<b>6078</b>	<b>Advertisement</b>	<b>0</b>	<b>125,000</b>	<b>125,000</b>	<b>125,000</b>	<b>125,000</b>	<b>110,000</b>	<b>(15,000)</b>
	Signage, Identity and Install		75,000	75,000	75,000	75,000	75,000	0
	Roll out of Mission, Vision, Goals and Strategic Plan		10,000	10,000	10,000	10,000	10,000	0
	Site Selection; Team Texas; Various conference exhibits/trade shows		15,000	15,000	15,000	0	0	(15,000)
	Print, radio and television ads		25,000	25,000	25,000	25,000	25,000	0
<b>6080</b>	<b>Staff Allocation</b>	<b>99,469</b>	<b>110,479</b>	<b>148,284</b>	<b>0</b>	<b>0</b>	<b>0</b>	<b>0</b>
	<b>Total Communications, Public Affairs, Marketing</b>	<b>264,469</b>	<b>445,479</b>	<b>490,984</b>	<b>369,000</b>	<b>279,700</b>	<b>(89,300)</b>	
<hr/>								
<b>Administration</b>		<b>FY 2017 Budget</b>	<b>FY 2018 Budget</b>	<b>FY 2019 Budget</b>	<b>FY 2020 Budget</b>	<b>FY 2021 Proposed Budget</b>	<b>Change</b>	
<b>6112</b>	<b>Administration Programs</b>	<b>0</b>	<b>15,990</b>	<b>10,240</b>	<b>7,815</b>	<b>7,520</b>	<b>(295)</b>	
	Greater Houston Partnership Dues		5,000	5,000	5,000	5,000	5,000	0
	Meaningful Change Participation		6,000	0	0	0	0	0
	American Planning Association		80	80	80	80	80	0
	IEDC Dues		610	610	0	0	0	0
	East End Chamber		300	300	300	300	300	0
	TEDC Dues		1,000	1,000	1,000	1,000	1,000	0
	American Marketing Association		295	295	295	0	0	(295)

**FY 2018\_FY 2019\_FY 2020 BUDGET**

	Houston Business Journal		140	140	140	140	0
	Training/ Continuing Education		850	850	1,000	1,000	0
	AAAE		850	850	0	0	0
	AMAC (Airport Minority Advisory Council)		500	500	0	0	0
	SEDC (Southern Economic Development Council)			250	0	0	0
	PRSA (Public Relations Society of America)		365	365	0	0	0
<b>6110</b>	<b>Staff Allocation</b>	<b>117,528</b>	<b>117,333</b>	<b>129,954</b>	<b>0</b>	<b>0</b>	<b>0</b>
<b>6115</b>	<b>Meeting Expenses</b>	<b>16,500</b>	<b>7,700</b>	<b>21,500</b>	<b>24,000</b>	<b>35,300</b>	<b>11,300</b>
	Stakeholder Meetings (2)		2,700			2,700	2,700
	January Meetings					2,300	2,300
	February Meetings					2,300	2,300
	March Meetings					2,300	2,300
	April Meetings					2,300	2,300
	May Meetings					2,300	2,300
	June Meetings					2,300	2,300
	July Meetings					2,300	2,300
	August Meetings					2,300	2,300
	September Meetings					2,300	2,300
	October Meetings					2,300	2,300
	November Meetings					2,300	2,300
	December Meetings					2,300	2,300
	Additional District Related Adhoc Meeting Expenses		5,000			5,000	5,000
<b>6120</b>	<b>Reimbursable Expenses</b>	<b>15,000</b>	<b>15,000</b>	<b>15,000</b>	<b>16,500</b>	<b>0</b>	<b>(16,500)</b>
	*LINE ITEM S/B ALLOCATED TO ACTUAL EXPENSE						0
<b>6125</b>	<b>Postage</b>	<b>280</b>	<b>280</b>	<b>500</b>	<b>550</b>	<b>1,000</b>	<b>450</b>
<b>6130</b>	<b>Office Supplies</b>	<b>7,500</b>	<b>7,500</b>	<b>7,500</b>	<b>10,000</b>	<b>5,000</b>	<b>(5,000)</b>
	Copier Paper		1,500			1,000	1,000
	Ink/Toner		1,200			1,000	1,000
	Misc. Office Supplies		1,500			1,000	1,000
	Computer Accessories		1,300			1,000	1,000

**FY 2018\_FY 2019\_FY 2020 BUDGET**

	F&B (Coffee, Water, Soft Drinks for meetings)		2,000			1,000	1,000
<b>6135</b>	<b>Public/Legal Notices</b>	<b>1,500</b>	<b>1,400</b>	<b>1,700</b>	<b>1,700</b>	<b>1,700</b>	<b>0</b>
	Posting for 6 Board meetings		100				0
	Posting for Public Hearing		1,300				0
<b>6140</b>	<b>Legal Services</b>	<b>47,500</b>	<b>47,500</b>	<b>47,500</b>	<b>55,000</b>	<b>70,000</b>	<b>15,000</b>
	Allen Boone Humphries						0
	Perdue, Brandon, Felder and Collins Delinquent Collections						0
<b>6145</b>	<b>Audit Services</b>	<b>7,550</b>	<b>12,500</b>	<b>19,600</b>	<b>45,000</b>	<b>45,000</b>	<b>0</b>
	McCall Gibson Swedlund Barfoot (External Audit)			16,000	20,000	20,000	0
	Internal Audit				20,000	0	(20,000)
	Audit Prep			3,600	5,000	5,000	0
<b>6150</b>	<b>Bookkeeping</b>	<b>9,000</b>	<b>10,500</b>	<b>10,500</b>	<b>12,000</b>	<b>12,000</b>	<b>0</b>
	Cindy Craig/Government Financial Reporting		10,500		12,000	12,000	0
<b>6155</b>	<b>Assessment Billing</b>	<b>32,500</b>	<b>35,000</b>	<b>35,000</b>	<b>38,500</b>	<b>38,500</b>	<b>0</b>
	Equitax						0
<b>6160</b>	<b>Assessment Database Mgmt.</b>	<b>3,600</b>	<b>4,000</b>	<b>4,000</b>	<b>4,400</b>	<b>4,400</b>	<b>0</b>
	Equitax						0
<b>6165</b>	<b>Office Equipment</b>	<b>30,000</b>	<b>15,000</b>	<b>15,000</b>	<b>15,000</b>	<b>2,000</b>	<b>(13,000)</b>
	Furniture		10,000		10,000	0	(10,000)
	Additional Office Equipment As Needed		5,000		5,000	2,000	(3,000)
<b>6170</b>	<b>Insurance</b>	<b>2,500</b>	<b>20,000</b>	<b>7,500</b>	<b>15,000</b>	<b>10,000</b>	<b>(5,000)</b>
	TML: General Liability						0
	Directors and Operators						0
	Errors and Omissions						0
	Property Casualty						0
	Worker's Comp						0
<b>6172</b>	<b>Office Lease</b>	<b>25,800</b>	<b>30,000</b>	<b>30,000</b>	<b>40,000</b>	<b>25,000</b>	<b>(15,000)</b>
<b>6173</b>	<b>Communication &amp; Technologies</b>	<b>25,000</b>	<b>24,950</b>	<b>28,950</b>	<b>34,350</b>	<b>29,950</b>	<b>(4,400)</b>
	Employee communication allowance		7,200	7,200	7,200	1,200	(6,000)

**FY 2018\_FY 2019\_FY 2020 BUDGET**

	Website Maintenance		4,200	4,200	4,200	0	(4,200)
	IT Consultant			2,500	2,500	7,000	4,500
	Office 365		900	900	1,200	3,000	1,800
	Adobe		700	700	700	700	0
	Ooma		1,450	1,450	2,650	2,650	0
	Comcast		2,700	2,700	3,000	3,000	0
	Premium LinkedIn Subscription			1,500	1,500	0	(1,500)
	OST (Copier)		2,400	2,400	2,400	2,400	0
	Great Financial (Copier)		4,200	4,200	4,200	4,200	0
	Dropbox		800	800	800	800	0
	QuickBooks Software		400	400	400	0	(400)
	Mail Chimp				3600	5,000	1,400
6175	Other (Ex. Bank Wire Transaction Fees)	750	750	300	1,500	1,500	0
	<b>Employee Payroll &amp; Benefits</b>						0
6180	Gross Wages				400,000	115,000	(285,000)
6181	Payroll Taxes				30,600	9,000	(21,600)
6182	Payroll Sevices				400	2,500	2,100
6183	Health Insurance				69,407	8,640	(60,767)
6184	Retirement Funds				1,133	2,000	867
	<b>Total Administration</b>	<b>342,508</b>	<b>365,403</b>	<b>384,744</b>	<b>321,315</b>	<b>288,870</b>	<b>(32,445)</b>
	<b>Total M&amp;O USES OF FUNDS</b>	<b>2,769,090</b>	<b>3,449,234</b>	<b>2,988,998</b>	<b>2,482,915</b>	<b>2,319,106</b>	<b>(163,809)</b>

M&O USES OF FUNDS	FY 2017 Budget	FY 2018 Budget	FY 2019 Budget	FY 2020 Budget	FY 2021 Budget
Total Projected Revenue and Reimburse	2,479,833	2,517,715	1,946,500	1,955,000	2,248,185
Total M&O Uses of Funds	2,769,090	3,449,234	2,988,998	2,482,915	2,319,106
Prior Year Reserves	1,511,104	1,511,104	1,335,142	1,229,955	1,115,963
Projected Year End Cash Reserves	1,221,847	579,585	292,644	702,040	1,045,042





## HOBBY AREA DISTRICT

(HARRIS COUNTY IMPROVEMENT DISTRICT NO. 9)

CITY OF HOUSTON

HARRIS COUNTY, TEXAS

---

---

### AGENDA MEMORANDUM

---

---

To: Hobby Area District Board of Directors  
From: Executive Director  
Subject: Agenda Item Materials

---

13. Set and approve Board and Committee meeting dates for remainder of 2020 and FY2021.



## HOBBY AREA DISTRICT

(HARRIS COUNTY IMPROVEMENT DISTRICT NO. 9)

CITY OF HOUSTON

HARRIS COUNTY, TEXAS

---

---

### AGENDA MEMORANDUM

---

---

To: Hobby Area District Board of Directors  
From: Executive Director  
Subject: Agenda Item Materials

---

14. Executive Director's Report/Board Member or Staff Announcements.